

12049**91-96 BUICK PARK AVENUE AND ELECTRA,
91-97 OLDSMOBILE NINETY-EIGHT AND REGENCY****10/12/2012****GROSS LOAD CAPACITY WHEN USED AS A WEIGHT CARRYING HITCH: 3,500 LBS. TRAILER WEIGHT & 350 LBS. TONGUE WEIGHT.*******DO NOT EXCEED VEHICLE MANUFACTURER'S RECOMMENDED TOWING CAPACITY.*******WARNING: ALL NON-TRAILER LOADS APPLIED TO THIS PRODUCT MUST BE SUPPORTED BY AUXILIARY STABILIZING STRAPS.****** FAILURE TO PROPERLY SUPPORT NON-TRAILER LOADS WILL VOID PRODUCT WARRANTY******HAVING INSTALLATION QUESTIONS? CALL TECHNICAL SUPPORT AT 1-877-287-8634**

| Parts List | | | |
|------------|-----|-----------------------|--|
| ITEM | QTY | PART NUMBER | DESCRIPTION |
| 1 | 6 | 3/8" | WASHER |
| 2 | 4 | 3/8" | CONICAL TOOTHED WASHER |
| 3 | 2 | 7/16-14 | HEX FLANGE NUT |
| 4 | 2 | 7/16 - 14 x 1 3/4 | CARRIAGE BOLT |
| 5 | 1 | CM-438-FW | 7/16" FISHWIRE TOOL |
| 6 | 2 | CM-SP7 | .250 x 1.00 x 2.00" SQUARE HOLE SPACER |
| 7 | 4 | 5/16-18 | HEX FLANGE NUT |
| 8 | 4 | 5_16 - 18 x 2 1_2 HEX | HEX BOLT |

FISHWIRE TECHNIQUE

INSERT COILED END OF FISHWIRE TOOL THROUGH HITCH MOUNTING HOLE IN VEHICLE FRAME RAIL AND OUT THE ACCESS HOLE. PASS COILED END OF FISHWIRE THROUGH SPACER AND THREAD BOLT INTO COIL. KINK WIRE TO KEEP SPACER SEPERATE FROM BOLT AS SHOWN. PULL FISHWIRE, SPACER, AND BOLT THROUGH FRAME AND OUT MOUNTING HOLE. USE FISHWIRE TO GUIDE HITCH DURING MOUNTING AND PREVENT LOSS OF BOLT / SPACER INSIDE FRAME RAIL.

NOTE: SOME VEHICLES MAY FISHWIRE THROUGH END OF FRAME

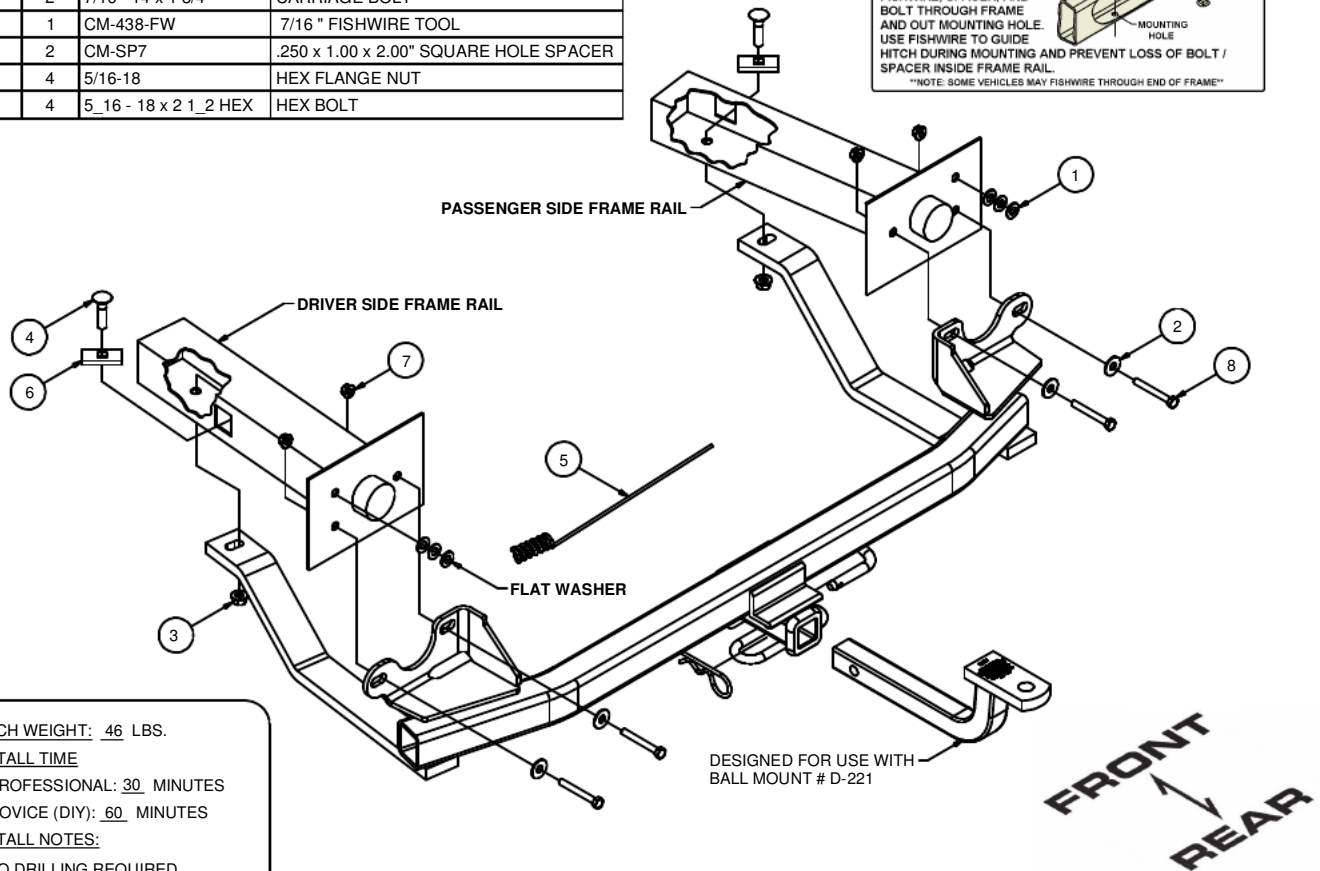
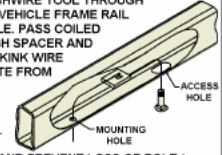
**HITCH WEIGHT: 46 LBS.****INSTALL TIME**

PROFESSIONAL: 30 MINUTES

NOVICE (DIY): 60 MINUTES

INSTALL NOTES:

-NO DRILLING REQUIRED

INSTALLATION STEPS

1. Remove inboard and lower outboard energy absorber (E/A) unit mounting bolts from both sides of frame. Remove upper outboard bolt that attaches tailpipe hanger bracket to end of frame on driver and passenger side.
2. Reposition air compressor filter (if equipped) on passenger side to forward hole.
3. Position hitch on vehicle and loosely install 5/16" fasteners provided.
4. Align holes in hitch side arms with existing hole in vehicle frame.
5. Install remaining fasteners as shown.
6. Use three 3/8 flat washers provided to shim space between tailpipe hanger bracket and upper outboard attachment for E/A unit on driver side and passenger side. Use existing fasteners to reattach tailpipe hanger bracket. (Note: Driver side tailpipe hanger bracket equipped on 1996 vehicles only).
7. Torque all 7/16" hardware to 70 ft-lbs. Torque all 5/16" hardware to 24 ft-lbs.

PERIODICALLY CHECK THIS RECEIVER HITCH TO ENSURE THAT ALL FASTENERS ARE TIGHT AND THAT ALL STRUCTURAL COMPONENTS ARE SOUND.

Curt Manufacturing Inc., warrants this product to be free of defects in material and/or workmanship at the time of retail purchase by the original purchaser. If the product is found to be defective, Curt Manufacturing Inc., may repair or replace the product, at their option, when the product is returned, prepaid, with proof of purchase. Alteration to, misuse of, or improper installation of this product voids the warranty. Curt Manufacturing Inc.'s liability is limited to repair or replacement of products found to be defective, and specifically excludes liability for incidental or consequential loss or damage.