

4" CURVED BAR

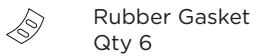

Components:

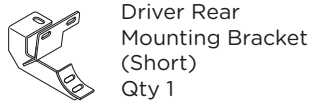
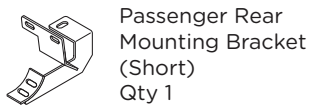
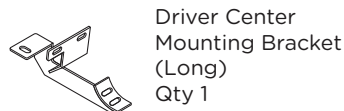
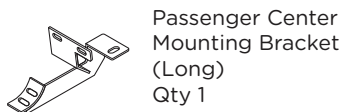
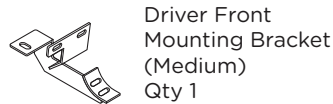
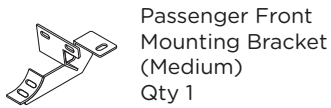
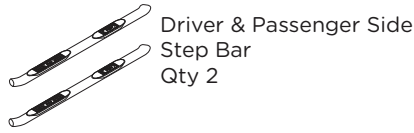

Hardware:

- | | |
|---------------------------------------|--------------------------------------|
| M10 Nut Plate
Qty 6 | M10 Flat Washer (30MM OD)
Qty 6 |
| M10 x 25MM Hex Head Bolt
Qty 6 | M10 Flat Washer (23MM OD)
Qty 12 |
| M10 x 30MM Button Head Bolt
Qty 12 | M10 Lock Washer
Qty 12 |
| M6 Hex Head Nut
Qty 12 | M6 Flat Washer
Qty 24 |
| M8 Lock Washer
Qty 6 | M6 x 25MM Button Head Bolt
Qty 12 |
| M8 Flat Washer
Qty 6 | M6 Lock Washer
Qty 12 |
| M8 x 35MM Hex Head Bolt
Qty 6 | |

Tools Required:

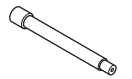
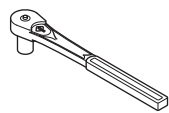

Torque Specifications:

For Rocker Panel Mount Installations
M8 through M12 bolts and nuts are set to 15-20 ft lbs.

Note: When installing the brackets and bars, all hardware must be left loose until all the items are attached.

1. On passenger side of jeep, align Front, Center and Rear Brackets as shown.

Rev 6

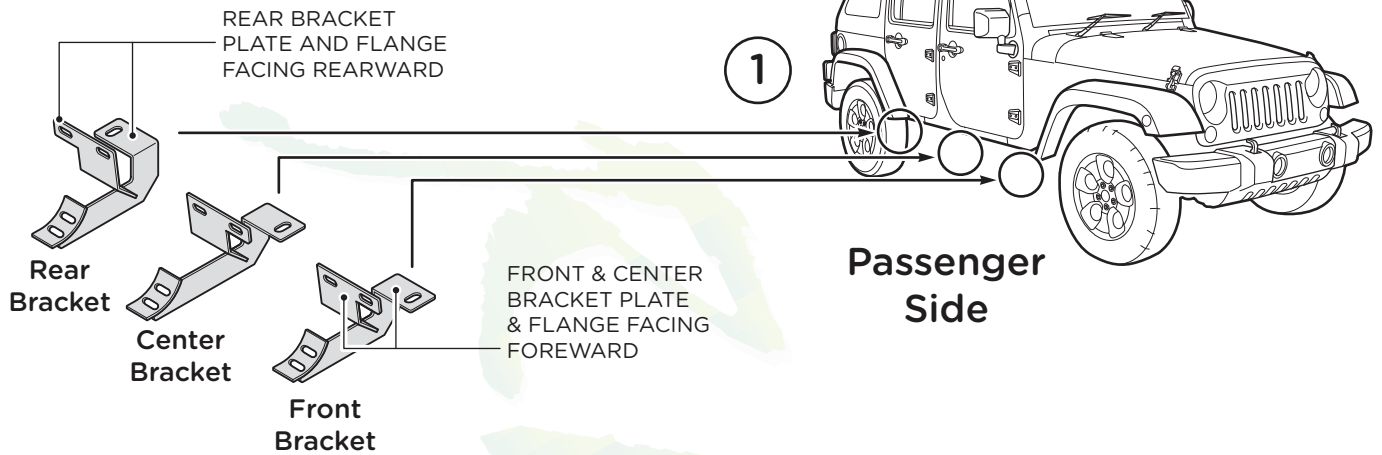

2. Starting on the passenger side front, locate the bracket mounting location on the underside of the Jeep body.

IF THE FRAME IS NOT PRE-THREADED

3. If the frame is not Pre-Threaded then you will install the brackets to the frame using the Non-Threaded Hardware Pack. Locate the square opening in the floor frame channel. Insert one (1) M10 Nut Plate into the opening. Next, fasten the bracket to the M10 Nut Plate using one (1) M10 x 25MM Hex Head Bolt, one (1) M10 Lock Washer and one (1) M10 Flat Washer.

Non-Threaded Hardware Pack

- M10 Nut Plate - Qty 6
- M10 x 25MM Hex Head Bolt - Qty 6
- M10 Flat Washer - Qty 6
- M10 Lock Washer - Qty 6

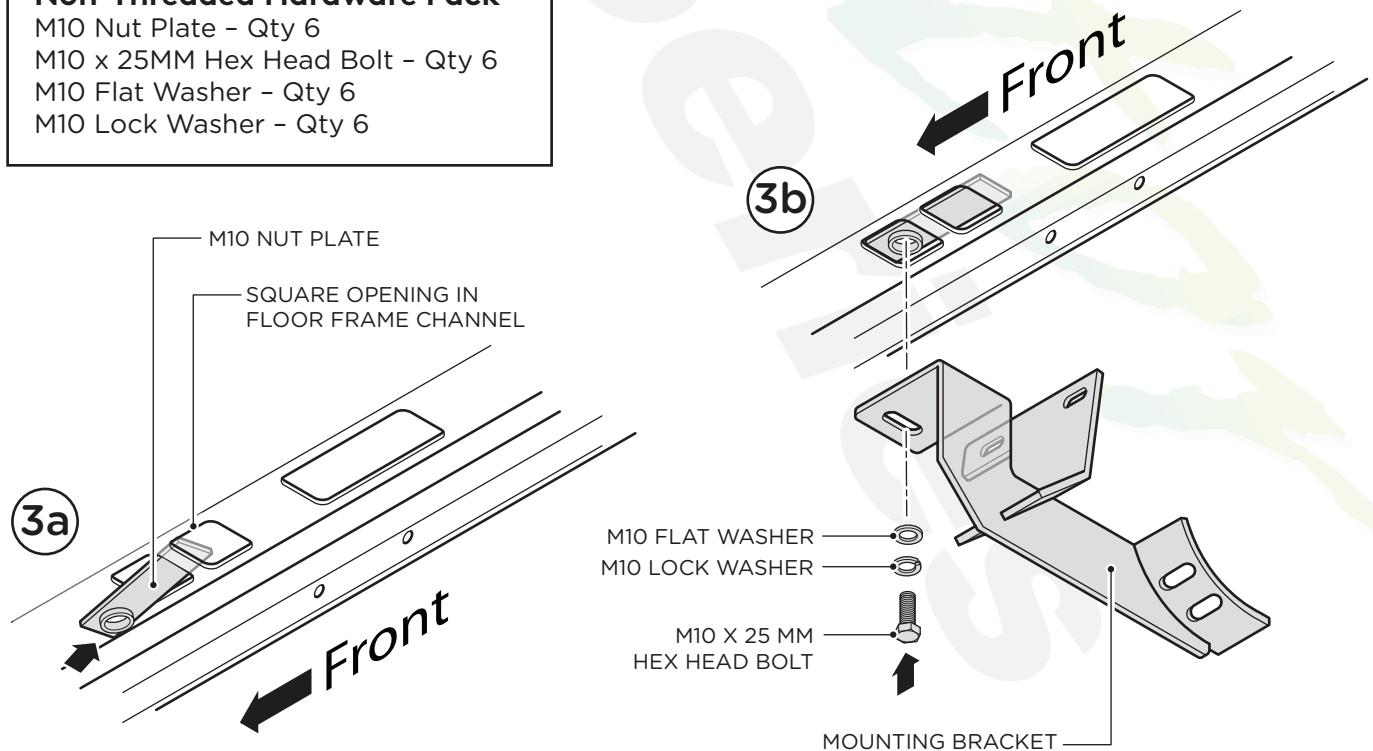

IF THE FRAME IS PRE-THREADED

4. If the frame is Pre-Threaded then you will install the brackets to the frame using the Pre-Threaded Hardware Pack. Start by fastening the bracket to the pre-threaded hole using one (1) M8 x 35MM Hex Head Bolt, one (1) M8 Lock Washer and one (1) M8 Flat Washer.

Pre-Threaded Hardware Pack
 M8 x 35MM Hex Head Bolt - Qty 6
 M8 Flat Washer - Qty 6
 M8 Lock Washer - Qty 6

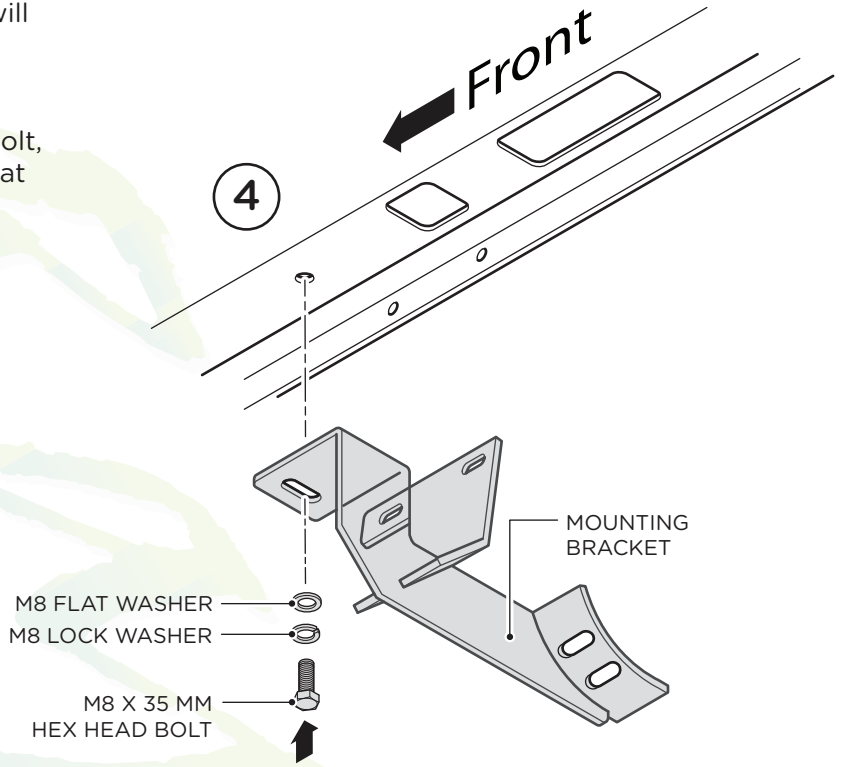

5. For both the Non-Threaded scenario and the Pre-Threaded scenario, attach the bracket to the pinch weld using two (2) M6 x 25MM Button Head Bolts, two (2) M6 Lock Washers and two (2) M6 Flat Washers.

Repeat this procedure for the remaining brackets.

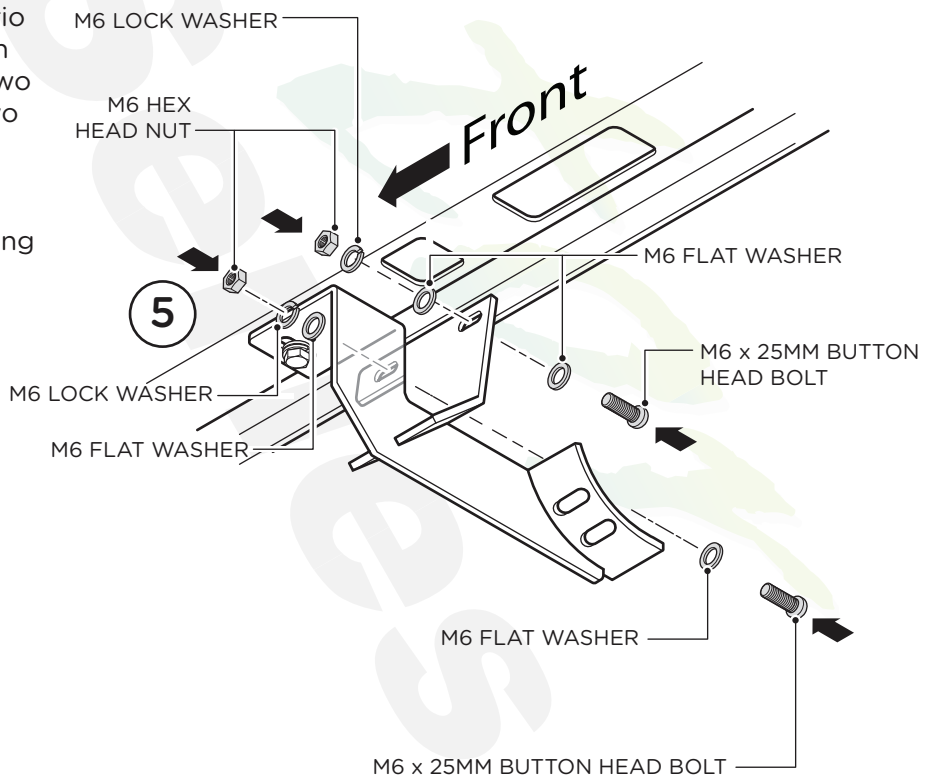

6. Place Step Bar and three (3) Rubber Gaskets onto Brackets.

7. Install Step Bar and Rubber Gasket onto each Bracket and attach using two (2) M10 Button Head Bolts, two (2) M10 Lock Washers and two (2) M10 Flat Washers per bracket.

Tighten until the split lock washer is flat against bracket and snug. DO NOT over tighten and strip the threaded insert in the tube.

Repeat these steps for driver side installation. When all hardware is in place, everything must be tightened. See Page 1 for Torque Specifications.

