



## INSTALLATION INSTRUCTIONS

2001-07 FORD ESCAPE / 2001-07 MAZDA TRIBUTE 2/4WD  
SIDE BAR PART #203012/203012-2

### **PARTS LIST**

- |                                              |                                      |
|----------------------------------------------|--------------------------------------|
| (2) SIDE TUBES WITH STEPS                    | (8) M8 – 125 x 30mm HEX HEAD BOLT    |
| (4) FRONT/CENTER MOUNT BRACKETS              | (8) M8 FLAT WASHER                   |
| (2) REAR MOUNT BRACKETS                      | (8) M8 SPLIT LOCK WASHER             |
| (2) 3/8" NUT PLATES                          | (4) 3/8" – 16 x 1.50" HEX HEAD BOLTS |
| (12) 3/8" – 16 x 1.00" BUTTON HEAD CAP SCREW | (4) 3/8" LOCK WASHER                 |
| (12) 3/8" LOCK WASHER                        | (4) 3/8" SAE FLAT WASHER             |

### **PROCEDURE**

1. Begin installation by working on driver side of the vehicle (refer to Figures 1. 1- 1.3)
2. Locate and remove (4) rubber drain plugs located on inside of rocker panel where the front and center mount brackets will be installed.  
**Note:** The plugs may be hidden under factory undercoating. Scrape away undercoating in this area to provide a flat surface for the brackets.
3. Attach front and center brackets (same bracket) to the inside rocker panel where the drain plugs were removed using (4) M8 – 1.25 x 30mm Hex Head Bolts, (4) M8 Lock Washers, and (4) M8 Flat Washers(see Figure 1.2). Hand tighten.
4. Locate the rear mounting holes (one slot and one hole) on the underside of the rocker panel, below the rear door. Insert (1) 3/8" Nut Plate into slot so holes of Nut Plate line up with mount holes on the vehicle(see Figure 1.3).  
**Note:** Extruded side of Nut Plate should face up.
5. Attach rear bracket to vehicle rocker panel using (2) 3/8" – 16 x 1.50" Hex Head Bolts, (2) 3/8" Lock Washers, and (2) 3/8" Flat Washers. Hand tighten bolts through Nut Plate.
6. Attach side tube to brackets using (6) 3/8" – 16 x 1.00" Button Head bolts and (6) 3/8" Lock Washers. Hand tighten.  
**Note:** Step Pad closer to the end of the tube goes to the rear. (see Figure 1.1).
7. Center and level Side tube. Tighten and torque 3/8" fasteners to 30 FT-LBS and M8 fasteners to 19 FT-LBS to complete assembly.
8. Repeat process for passenger side of vehicle to complete installation.

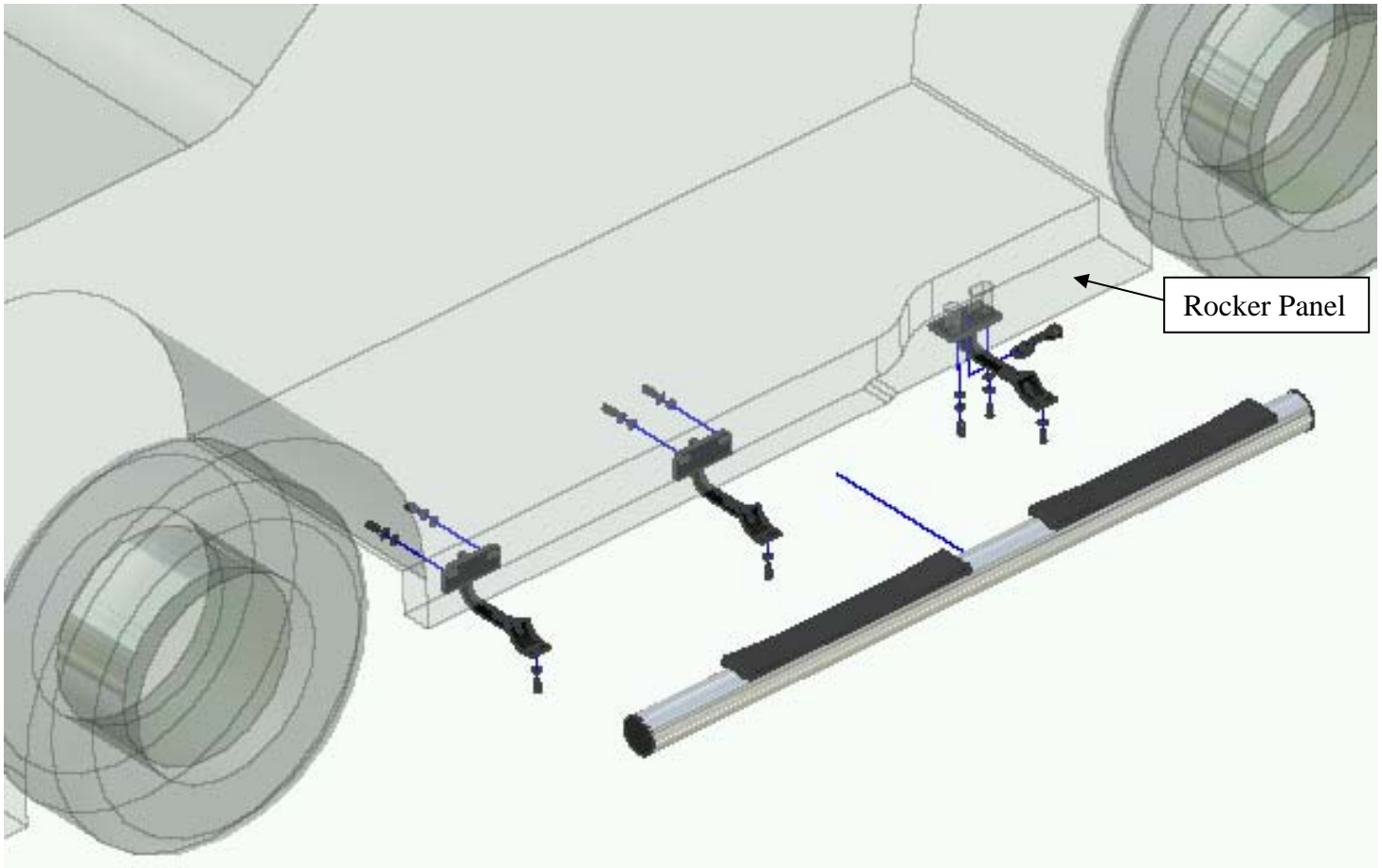

Figure 1.1 - Front Driver-Side View

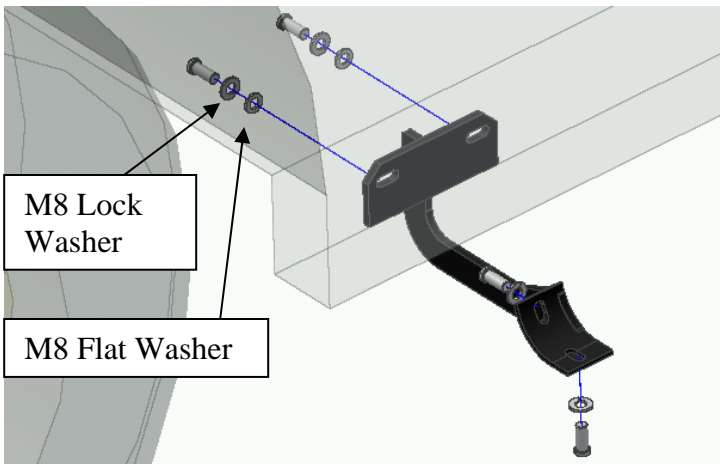

Figure 1.2 - Front and Center Bracket

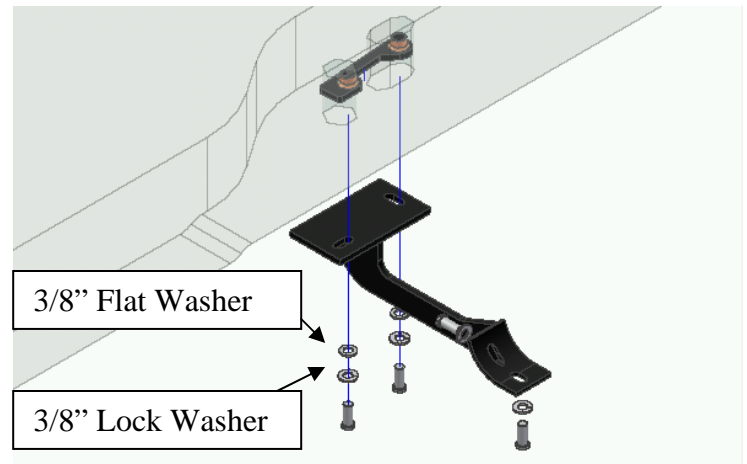

Figure 1.3 - Rear Bracket

**FINISH PROTECTION-** ARIES PRODUCTS HAVE A HIGH FINISH THAT MUST BE MAINTAINED SUCH AS ANY OTHER HIGH FINISH PRODUCT ON THE VEHICLE. PROTECT THE FINISH WITH A NON-ABRASIVE AUTOMOTIVE WAX. THE USE OF SOAP, POLISH, OR WAX THAT CONTAINS ABRASIVES IS DETRIMENTAL, AS THE COMPOUNDS SCRATCH THE FINISH AND OPEN IT TO CORROSION.

**DISCLAIMER-** BUYER ASSUMES ALL RISK AND LIABILITY WHATSOEVER FROM THE INSTALLATION AND USE OF ARIES PRODUCTS. ARIES PRODUCTS ARE SOLD AS DECORATIVE ACCESSORIES AND SHOULD NOT BE RELIED UPON AS PROTECTION FOR THE VEHICLE OR OCCUPANTS IN THE EVENT OF A COLLISION OR ROLL OVER. ARIES AUTOMOTIVE ASSUMES NO LIABILITY FOR INJURY, LOSS, INCIDENTAL OR CONSEQUENTIAL DAMAGES IN THE EVENT OF A COLLISION OR ROLLOVER