

IMPORTANT:

The manufacturer is not responsible for negligent use of vehicle with mud flaps installed, including over-tightening of screws and bolts causing damage to vehicle or mud flaps.

TOOLS REQUIRED:

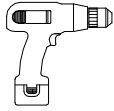

Electric or Chargeable
 1/2" or 3/8" drill



#2 Phillips screwdriver

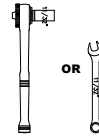

13mm wrench or
 socket wrench



5/16" Socket Driver

KIT CONTAINS:

a) (1) Mount Bracket,
 Rear, DS
 Part #755558

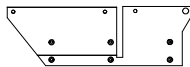

b) (1) Mount Bracket
 Rear, PS
 Part #755559

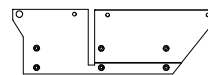

c) (6) Screw, TEK
 1/4" x 1 1/4"
 Part #010011



d) (12) Machine Screw
 #8-32 x 5/16
 Part #012023



e) (12) T-Nut
 #8 – 32
 Part #016028



f) (6) Flat Washers
 0.281 x 1"
 Part #018028

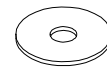

INSTALLATION

1. Before you install your mud flaps, see the diagram and parts list for all necessary parts. (Start on driver's side)
2. Fasten the DS mount bracket to the driver's side flap with six machine screws and six -nuts. (See Diagram #1)

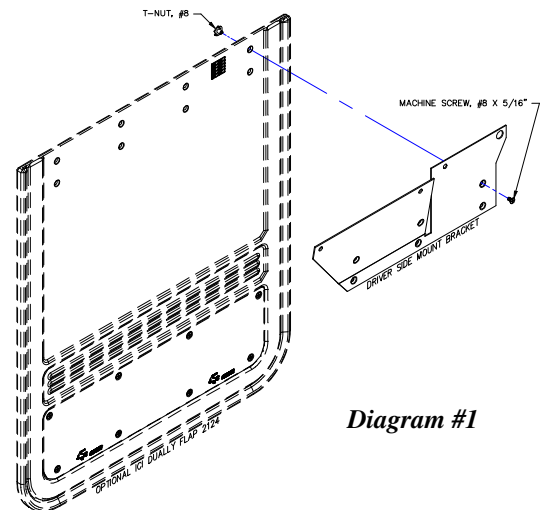
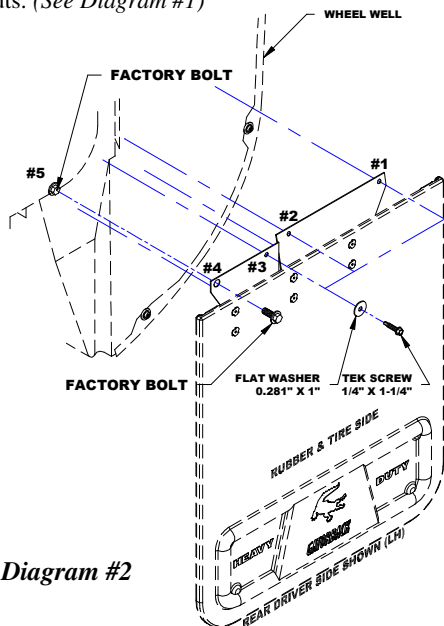

3. Remove the factory bolt #5 and reinstall through the mount bracket hole #4. Loosely secure at this point. (See diagram #2)
4. Square the flap with the tire and put the mount bracket up against the wheel hub and secure the mount bracket with three tek screws and three flat washers. Tighten the factory bolt. (See Diagram 2)

Check all fasteners for tightness. Repeat procedure on the other side

