

INSTALLATION INSTRUCTIONS AND PARTS LIST

VEHICLE APPLICATION:

MODEL 259924 (20.25" X 23.00") DUAL WHEEL MUDGUARDS
1999 AND NEWER FORD SUPER DUTY DUAL WHEEL TRUCKS

1. READ INSTRUCTIONS COMPLETELY AND CHECK TO MAKE SURE THAT ALL REQUIRED PARTS (LISTED ON SERVICE PARTS LIST) ARE ON HAND BEFORE STARTING THE INSTALLATION.

2. PREPARE THE VEHICLE FOR MUDGUARD INSTALLATION AS FOLLOWS:
 - 2.1. REMOVE THE FACTORY SCREW AND NUT THAT ATTACHES THE MOLDED DUAL FENDER TO THE METALLIC BOX ROCKER PANEL. (THESE ARE METRIC FASTENERS THAT REQUIRE 10MM AND 13MM WRENCHES). USING THESE SAME FASTENERS, ATTACH THE MOUNTING BRACKET (ITEM #2 & #3) SO THAT THE BENT FLANGE OF THE BRACKET LIES ON TOP OF THE METALLIC ROCKER PANEL. (POSITION THE BRACKET SO THAT THE FASTENER IS ABOUT CENTERED IN THE SLOTTED HOLE OF THE BRACKET).
 - 2.2. USING THE TWO HOLES IN THE MOUNTING BRACKET AS A PILOT, DRILL (2) 9/32" DIA. HOLES THRU THE PLASTIC WHEEL WELL LINER. (THIS WILL BE DONE FROM UNDER THE TRUCK).
 - 2.3. USING THE UPPER HOLE, APPROX. 6.00" UP FROM THE BOTTOM IN THE METALLIC WHEEL WELL FLANGE, AS A PILOT, DRILL A 9/32" DIA. HOLE THRU THE PLASTIC WHEEL WELL LINER. (THIS ALSO WILL BE DONE FROM UNDER THE TRUCK).

MOUNTING 259924 MUDGUARDS: (SEE SHEET #2)

3. INSTALL THE MUDGUARDS AS FOLLOWS:
 - 3.1. POSITION THE MUDGUARD AGAINST THE WHEEL WELL FLANGE AND PLASTIC LINER SO THAT THE HOLES IN THE MUDGUARD LINE UP WITH THE HOLES THAT WERE DRILLED THRU THE WHEEL WELL LINER PER INSTRUCTION #2.2 AND #2.3.
 - 3.2. INSTALL 1/4-20 X 1.25" BUTTON HEAD SCREW (ITEM #4), 1/4" FLAT WASHERS (ITEM #6) AND 1/4-20 SERRATED FLANGE NUTS (ITEM #5) THRU THE MUDGUARD, WHEEL WELL FLANGE, AND BRACKET AS SHOWN.
 - 3.3. MOVE THE MUDGUARD IN OR OUT AS DESIRED, LEVEL THE MUDGUARD AND TIGHTEN THE FASTENERS.



(A LUVERNE Company)

1200 E. Birch St.

Brandon, SD 57005

550196 SHEET 1 OF 2 08SEP08

SERVICE PARTS LIST

1999 FORD SUPER DUTY DUALY
MODEL NO. - 259924

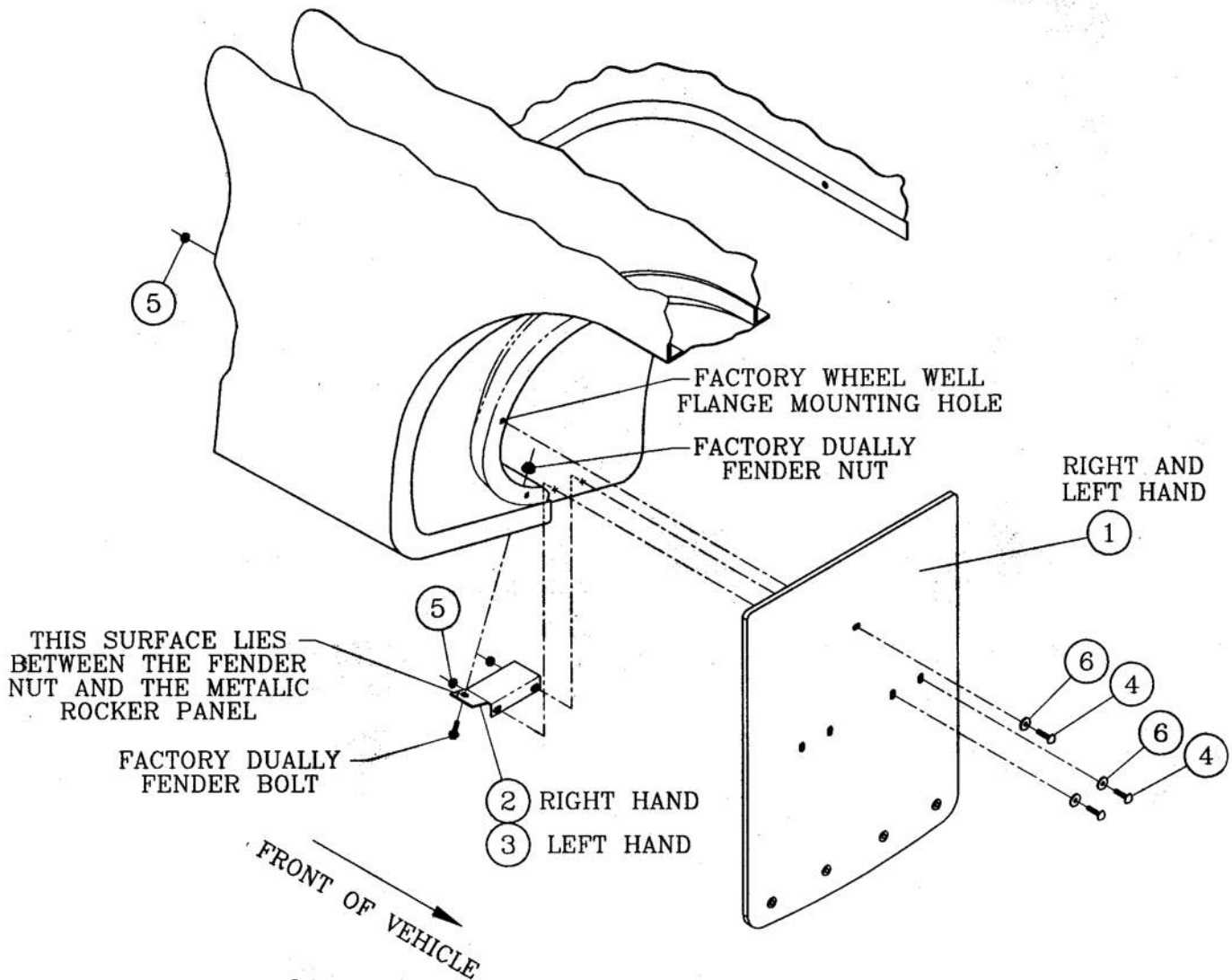

fig.1

RIGHT (PASSENGER) SIDE SHOWN

ITEM	PART NO.	QTY	DESCRIPTION
1	550195	2	MUDGUARD-RUBBER,20 X 23,FORD S.D. DUALY
2	549989	1	BRACKET- MTG, RIGHT HAND, 11GA GALV, BLK
3	549990	1	BRACKET- MTG, LEFT HAND, 11GA GALV, BLK
4	108053	6	SCR-BTN HD SOC, SST, 1/4-20 X 1-1/4", BZP
5	102366	6	NUT- HEX, SERRATED FLANGE,SST, 1/4-20
6	108521	6	WASHER- FENDER, 1/4 X 1, SST, 18-8, BZP

LIVERNE
TRUCK EQUIPMENT

(A LIVERNE Company)

1200 E. Birch St.

Brandon, SD 57005

REVISED 27JUL09 LVL A
550196 SHEET 2 08SEP08