

# INSTALLATION INSTRUCTIONS AND PARTS LIST

MODEL 415054, 415060, GRIP STEPS (BOARDS ONLY)  
UNIVERSAL APPLICATIONS

1. Read instructions completely and check to make sure that all required parts (listed on the service parts list) are on hand before starting the installation.
2. Follow the instructions included with the specific bracket package that you are using to mount the brackets to your vehicle.
3. Step assembly:
  - 3.1 Before attaching the grip steps to the brackets, slide the appropriate number of support braces (item #2) into the channel of the step (item #1).
  - 3.2 Slide the end cap (item #3) over the front and rear of each step. Using the supplied #8 x 1/2" self drilling tek screw (item #8), screw the end cap to the bottom of the step.
4. Attaching the step to the mounting bracket:
  - 4.1 Set the step on the mounting brackets, and slide each support brace over the top of each mounting bracket. Attach the flat spacer plate (item #4) to the bottom of the step, between the support brace, and the top of the mounting bracket.
  - 4.2 Using the supplied 5/16-18 x 1" carriage bolt, washer, and flange nuts, (item #5, 6, 7), attach the step assembly, flat spacer plate and mounting bracket. **(NOTE: Some of the flange nuts are supplied in the specific bracket package, not the step package.)**
  - 4.3 Set the step plate in the correct position and tighten all fasteners.  
Torque all 5/16" fasteners to 19 LB FT.

## SERVICE PARTS LIST

ITEM	PART NO.	QTY	DESCRIPTION
1	551954	2	EXTRUSION-AL,54, GRIP STEP,BLK,415054
1	551955	2	EXTRUSION-AL,59.62,GRIP STEP,BLK,415060
2	551296	6	SUPPORT BRACE, UPPER, GALV
3	551394	4	CAP-END,GRIP STEP, BLACK, PLASTIC
4	551298	6	SPACER PLATE, LOWER, BLACK
5	108683	12	BOLT-CRG,5/16-18 X 1.0", SST
6	101369	12	WASHER-FLAT,5/16,SST
7	102680	12	NUT-SERR FLG,HX,SST,WX,5/16-18
8	107958	8	SCR-TEK #8-18 X 1/2",SST,BLK



(A LIVERNE Company)

1200 E. Birch St.

Brandon, SD 57005

551958 SHEET 1 OF 2 22JUL11

SERVICE PARTS LIST

MODEL NO. - 415054  
- 415060

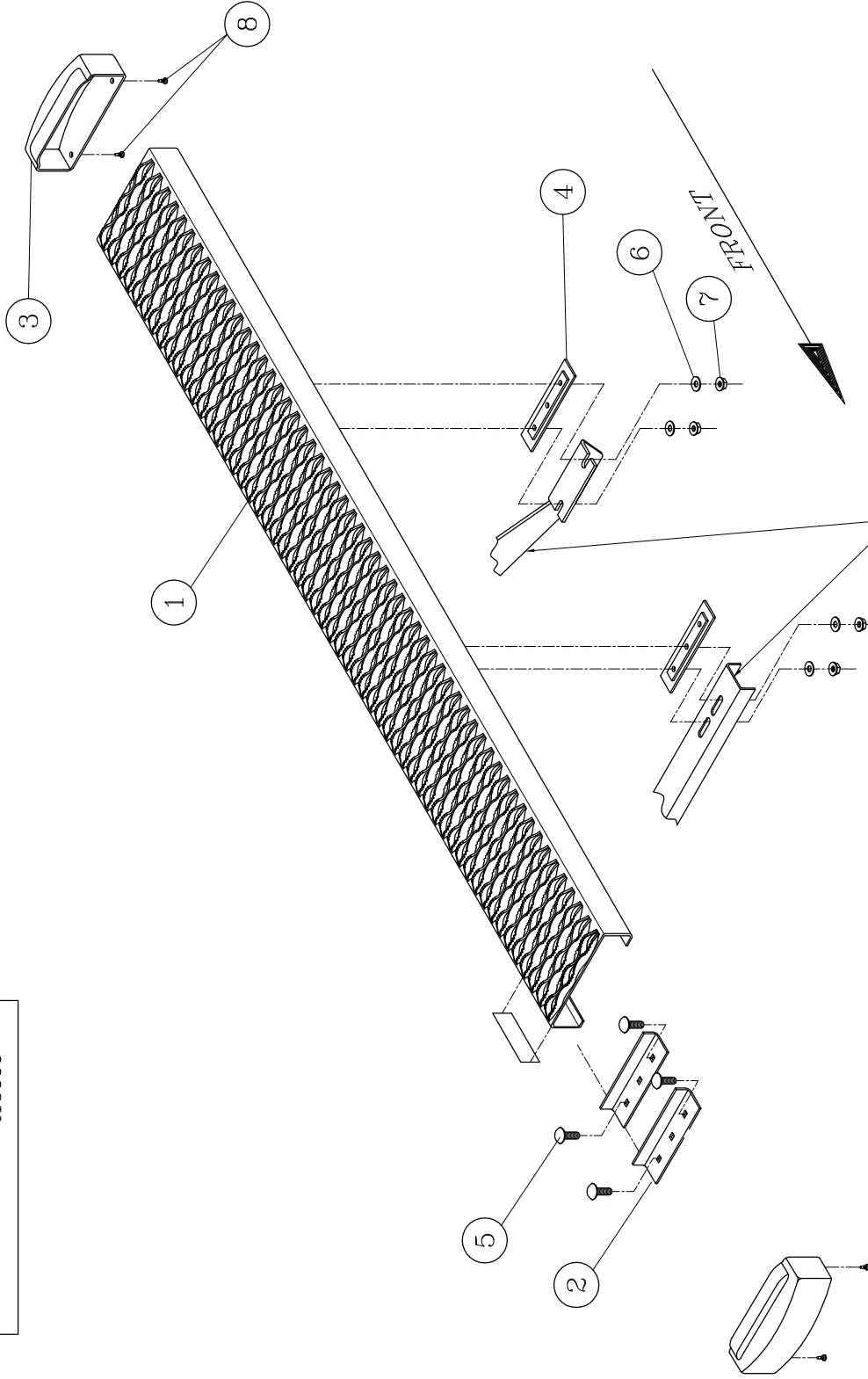

MOUNTING BRACKET SHOWN  
FOR VISUAL EFFECT ONLY  
(NOT INCLUDED)

**LOVERNE**  
TRUCK EQUIPMENT

(A LOVERNE COMPANY)

1200 E. Birch St.  
Brentwood, SD 57006

## INSTALLATION INSTRUCTIONS AND PARTS LIST

APPLICATION: MODEL 401521, 401721 GRIP STEP BRACKETS ON:  
2015+ FORD F-150 / 2017+ FORD SUPER DUTY REGULAR CAB PICKUPS  
**ROCKER PANEL MOUNT APPLICATION**



### NO DRILL APPLICATION

1. READ INSTRUCTIONS COMPLETELY AND CHECK TO MAKE SURE THAT ALL REQUIRED PARTS (LISTED ON SERVICE PARTS LIST) ARE ON HAND BEFORE STARTING THE INSTALLATION.
2. ON THE LEFT SIDE OF THE VEHICLE INSTALL TWO 1.5" ISOLATOR WASHERS (ITEM #3) THE STEP MOUNTING BRACKET (ITEM #2) AND TWO M8-1.25 FLANGE NUTS (ITEM #4) ON THE FACTORY PROVIDED STUDS ON THE INSIDE OF THE ROCKER PANEL AS SHOWN IN FIGURE 1.
3. REPEAT STEP 2 FOR THE REMAINING BRACKETS.
4. CHECK THAT ALL BRACKETS ARE LEVEL AND TIGHTEN ALL FLANGE NUTS.
5. REAPEAT STEPS 2 – 4 FOR THE RIGHT SIDE OF THE VEHICLE.

#### **ATTACHING THE STEP BOARDS TO THE BRACKETS:**

PLEASE REFER TO THE INSTRUCTION SHEET INCLUDED WITH YOUR STEP BOARD ASSEMBLY TO MOUNT THE STEP TO THE BRACKETS.

### SERVICE PARTS LIST

ITEM	PART NO.	QTY	DESCRIPTION
1		1	STEP ASSY, GRIP STEP
2	552845	4	BRACKET-MTG, GRIP STEP, 401521
2	553168	4	BRACKET-MTG, GRIP STEP, 401721
3	108442	8	WASHER – NYLON, .36" X 1.5" X .032" BLACK
4	105859	8	NUT- FLANGE, M8-1.25, ZP

SERVICE PARTS LIST

MODEL NO. - 401521  
401721

# REGULAR CAB

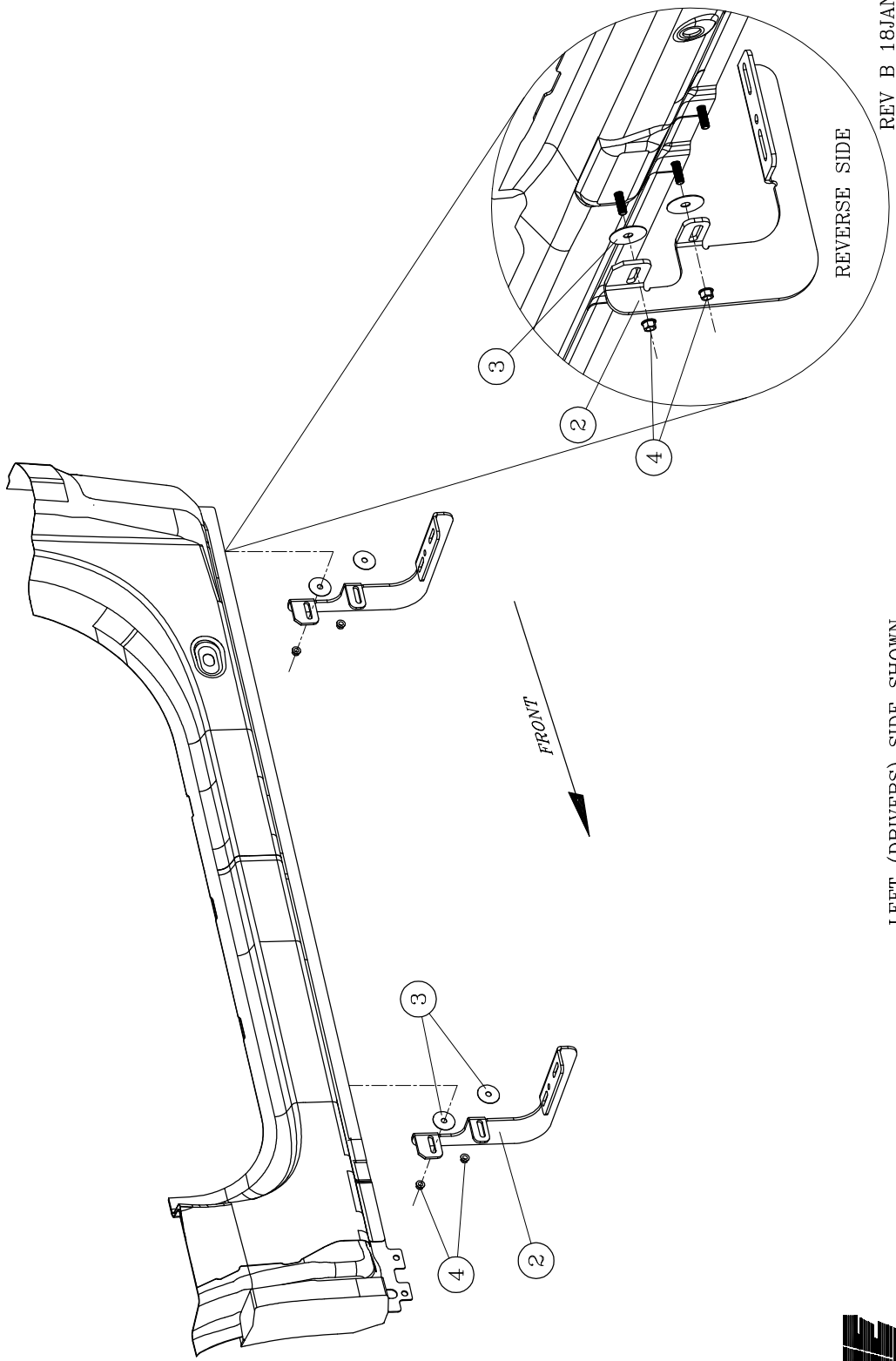

REV B 18JAN17  
REV A 30DEC16  
552826 SHEET 2 OF 2 27JAN15

- LEFT (DRIVERS) SIDE SHOWN -  
- RIGHT (PASSENGER) SIDE OPPOSITE -

