

INSTALLATION INSTRUCTIONS AND PARTS LIST

MODELS:

477097, 477101, 477113 (EXTENDED CABS)
477102, 477108, 477114, 477125 (CREW CABS)
REGAL 7 OVAL STEPS (BOARDS ONLY)
UNIVERSAL APPLICATIONS



1. Read instructions completely and check to make sure that all required parts (listed on the service parts list) are on hand before starting the installation.
2. Follow the instructions included with the specific bracket package that you are using to mount the brackets to your vehicle.
3. The step is pre-assembled from the factory. The serial number label is located on the front inside drivers side step assembly.
4. Attaching the step to the mounting bracket:
 - 4.1 Set the step on the mounting brackets, and slide each support mounting plate (item #9) inside the oval step and above each bracket.
 - 4.2 Using the supplied 5/16-18 x 1" black stainless steel hex bolt, washer, and serrated flange nut (items # 10,11&12) attach the step assembly, support mounting plate and mounting bracket.
 - 4.3 Set the step plate in the correct position and tighten all fasteners.
Torque all 5/16" fasteners to 19 LB FT.



(A LUVERNE Company)

1200 E. Birch St.

Brandon, SD 57005

REV A 31JUL12
552088 SHEET 1 OF 3 07MAY12

SERVICE PARTS LIST

ITEM	PART NO.	QTY	DESCRIPTION
1	552074	1	REGAL 7 OVAL STEP, LH,96",477097, EXT CAB
2	552075	1	REGAL 7 OVAL STEP, RH,96",477097, EXT CAB
1	552076	1	REGAL 7 OVAL STEP, LH,100",477101, EXT CAB
2	552077	1	REGAL 7 OVAL STEP, RH,100",477101, EXT CAB
1	552078	1	REGAL 7 OVAL STEP, LH,112",477113, EXT CAB
2	552079	1	REGAL 7 OVAL STEP, RH,112",477113, EXT CAB
1	552080	1	REGAL 7 OVAL STEP, LH,100",477102, CREW CAB
2	552081	1	REGAL 7 OVAL STEP, RH,100",477102, CREW CAB
1	552501	1	REGAL 7 OVAL STEP, LH, 106",477108, CREW CAB
2	552502	1	REGAL 7 OVAL STEP, RH, 106",477108, CREW CAB
1	552082	1	REGAL 7 OVAL STEP, LH,112",477114, CREW CAB
2	552083	1	REGAL 7 OVAL STEP, RH,112",477114, CREW CAB
1	552084	1	REGAL 7 OVAL STEP, LH,123",477125, CREW CAB
2	552085	1	REGAL 7 OVAL STEP, RH,123",477125, CREW CAB
3	109233	2	END CAP LH REAR, RH FRONT,BLK PLASTIC
4	109232	2	END CAP RH REAR, LH FRONT,BLK PLASTIC
5	107863	8	BOLT-CARRAIGE, 10-24 X 0.50,SST, BLACK
6	108909	6	STEP PAD, 25" X 6.5", PLASTIC, BLACK
7	108908	36	BOLT-CARRAIGE, 10-24 X 1.0,SST, BLACK
8	107864	44	NUT-NYLOCK, 10-24, SST
9	552052	10	SUPPORT MTG PLT, 11 GA, GALV
10	106997	20	SCREW-HEX HD, 5/16-18X1.0,SST,BLACK
11	106998	20	WSHR-FLAT, 5/16, SST, BLACK
12	102680	20	NUT-SER FLG, 5/16-18, SST
13	108913	2	STEP PAD, 15" X 6.5", PLASTIC (IF NEEDED)



(A LIVERNE Company)

1200 E. Birch St.

Brandon, SD 57005

REV B 06JUN14

REV A 31JUL12

552088 SHEET 2 OF 3 07MAY12

SERVICE PARTS LIST

MODEL NO.	—	477097
	—	477101
	—	477102
	—	477108
	—	477113
	—	477114
	—	477125

NOTE:
SOME APPLICATIONS WILL
USE A SMALL STEP PAD
FOR THE BOX STEP.

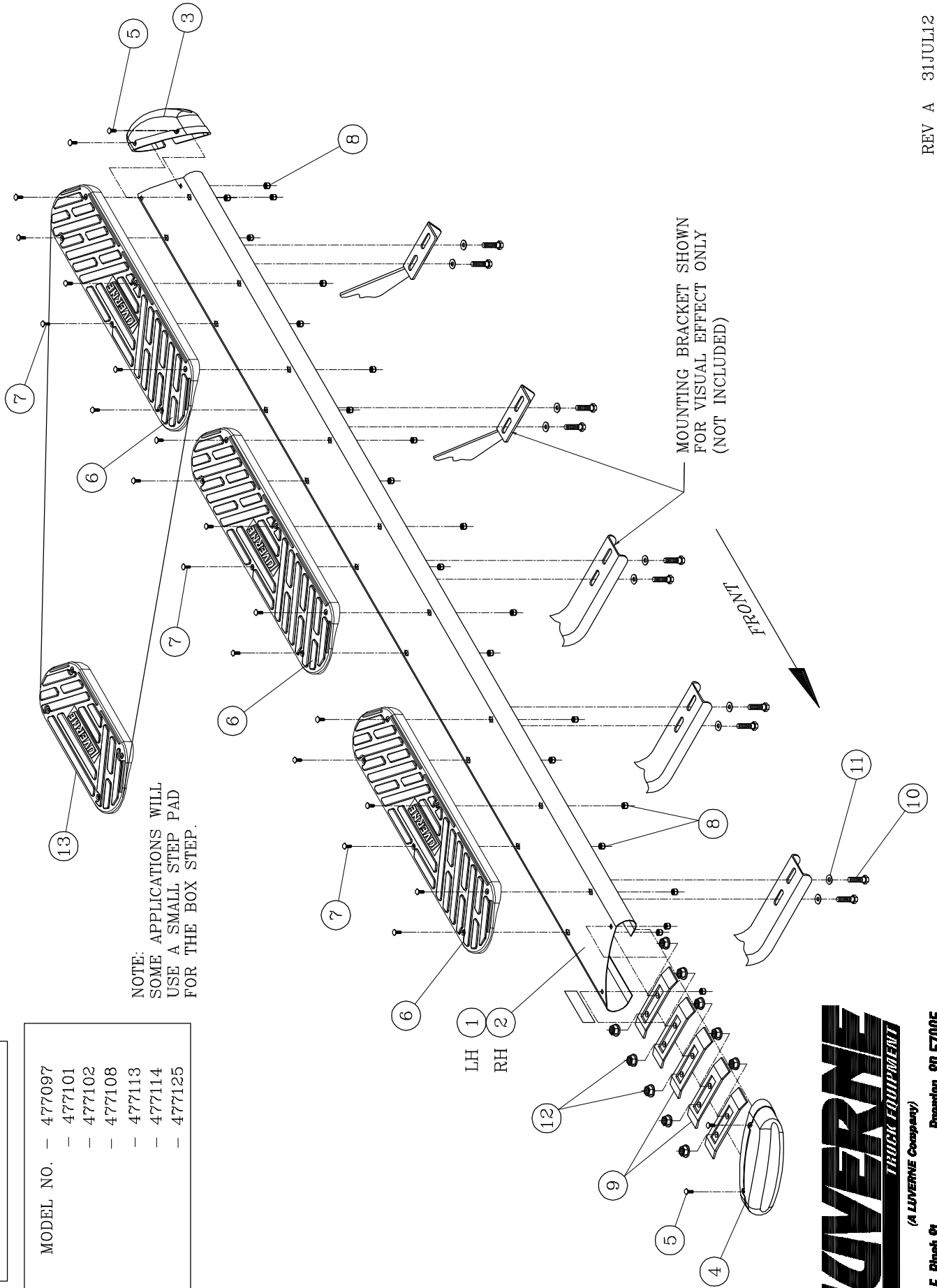

LIVERNE
TRUCK EQUIPMENT
(A LIVERNE Company)

1200 E. Birch St.
Brandon, SD 57005



INSTALLATION INSTRUCTIONS AND PARTS LIST
APPLICATION: MODEL 401438 REGAL 7/GRIP STEP BRACKET KIT:
2014+ DODGE RAM 2500 CAB PICKUPS



1. READ INSTRUCTIONS COMPLETELY AND CHECK TO MAKE SURE THAT ALL REQUIRED PARTS (LISTED ON THE SERVICE PARTS LIST) ARE ON HAND BEFORE STARTING THE INSTALLATION.
2. ATTACH THE MOUNTING BRACKETS TO THE VEHICLE AS FOLLOWS:

RAM TRUCKS WITH THREADED INSERTS IN THE ROCKER PANEL.

- 2.1 PLACE THE DRIVERS SIDE FRONT BRACKET (ITEM #1) UP TO THE PINCHWELD SO THAT THE LOWER MOUNTING FLANGE IS TO THE OUTSIDE OF THE PINCHWELD, ALIGN THE TWO RECTANGULAR HOLES OF THE LOWER MOUNTING FLANGE OF (ITEM #1) WITH THE TWO OBOUNDED HOLES IN THE PINCHWELD, INSERT THE TWO 1/4-20 X 1" CARRIAGE BOLTS (ITEM #9) THROUGH THE LOWER MOUNTING FLANGE AND THEN THROUGH THE PINCHWELD, PLACE A 1/4" FLAT WASHER (ITEM #10), AND 1/4-20 FLANGE NUT (ITEM #11) ON TO THE CARRIAGE BOLTS, LEAVE FINGER TIGHT. **SEE FIGURES 1 & 2.**
- 2.2 INSERT AN M8 X 25mm SCREW (ITEM # 12) WITH A 5/16" FLAT WASHER (ITEM #13) THROUGH THE SLOTS ON THE UPPER MOUNTING FLANGE, LEAVE FINGER TIGHT.
- 2.3 REPEAT STEPS 2.1 & 2.2 ON THE MIDDLE, AND REAR BRACKETS (ITEM #2) .
- 2.4 FOR THE PASSENGER SIDE THE INSTALLATION IS A MIRROR IMAGE OF THE DRIVERS SIDE, USE (ITEM #2) FOR THE FRONT BRACKET, (ITEM #1) FOR THE MIDDLE, AND REAR BRACKET.

RAM TRUCKS WITHOUT THREADED INSERTS IN THE ROCKER PANEL.

- 2.5 ON THE VERTICAL WALL OF THE ROCKER PANEL, INSTALL THE T-BOLT WELDMENT (ITEM #15) INTO THE LARGE OBOUNDED HOLE INSERTING THE NUT END FIRST, LEAVING THE THREADED STUD STICKING OUT OF THE OBOUNDED HOLE. **BE CAREFULL NOT TO DROP THE T-BOLT INSIDE OF THE ROCKER PANEL.** ATTACH THE FLAT PLASTIC BOLT RETAINER (ITEM #16) TO THE THREADED STUD OF THE T-BOLT. (THIS IS TO KEEP THE T-BOLT FROM FALLING INTO THE ROCKER PANEL.)
- 2.6 PLACE THE DRIVERS SIDE FRONT BRACKET (ITEM #1) UP TO THE PINCHWELD SO THAT THE LOWER MOUNTING FLANGE IS TO THE OUTSIDE OF THE PINCHWELD, ALIGN THE TWO RECTANGULAR HOLES OF THE LOWER MOUNTING FLANGE OF (ITEM #1) WITH THE TWO OBOUNDED HOLES IN THE PINCHWELD, INSERT THE TWO 1/4-20 X 1" CARRIAGE BOLTS (ITEM #9) THROUGH THE LOWER MOUNTING FLANGE AND THEN THROUGH THE PINCHWELD, PLACE A 1/4" FLAT WASHER (ITEM #10), AND 1/4-20 FLANGE NUT (ITEM #11) ON TO THE CARRIAGE BOLTS, LEAVE FINGER TIGHT. **SEE FIGURES 3 & 4.**
- 2.7 PLACE A FLAT WASHER (ITEM #13), AND AN M8 FLANGE NUT (ITEM #14), ON THE THREADED STUD OF THE T-BOLT (ITEM #15) LEAVE FINGER TIGHT.
- 2.8 ROTATE THE T-BOLT SO THAT THE THREADED NUT IS VISIBLE THROUGH THE SLOTTED HOLE IN THE UPPER MOUNTING FLANGE, INSERT AN M8 X 25mm SCREW (ITEM #12) WITH A 5/16" FLAT WASHER (ITEM #13), LEAVE FINGER TIGHT.
- 2.9 REPEAT STEPS 2.5 THRU 2.8 ON THE MIDDLE AND REAR BRACKETS (ITEM #2).
- 2.10 FOR THE PASSENGER SIDE THE INSTALLATION IS A MIRROR IMAGE OF THE DRIVERS SIDE, USE (ITEM #2) FOR THE FRONT BRACKET, (ITEM #1) FOR THE MIDDLE, AND REAR BRACKET.

3. ATTACH THE MOUNTING BRACKETS TO THE SHACKLE MOUNT OF THE VEHICLE AS FOLLOWS.
 - 3.1. ATTACH THE UPPER MOUNTING BRACKET (ITEM #3) TO THE SIDE OF THE SUSPENSION LINK HOUSING BY LOOSENING THE BOLT THAT FASTENS THE SUSPENSION LINKS TO THE VEHICLE. SLIDE THE UPPER MOUNTING BRACKET (ITEM #3) BETWEEN THE BOLT HEAD AND THE FRAME BRACKET. TIGHTEN DOWN THE BOLT MAKING SURE THAT THE UPPER MOUNTING BRACKET (ITEM #3) IS LEVEL.
 - 3.2. FASTEN THE LOWER BRACKET (ITEM #5) TO THE UPPER BRACKET (ITEM #3) USING 3/8 BOLT, WASHER AND NUT (ITEM #6, 7, 8) USING THE TWO LOWER HOLES IN THE UPPER BRACKET. MAKING SURE THAT IT SITS LEVEL TO THE FRONT BRACKETS.
4. INSTALL THE STEP PLATES, AND ADJUST BRACKETS, AND BOARDS BEFORE TIGHTENING ALL THE FASTENERS.

SERVICE PARTS LIST

ITEM	PART NO.	QTY	DESCRIPTION
1	553092	3	BRKT-MTG, WLDMNT, FRONT LH, MID RH. 401632
2	553093	3	BRKT-MTG, WLDMNT, FRONT RH, MID LH. 401632
3	552411	1	BRKT-MTG, GRIP, W2W, LH, INBOARD
4	552412	1	BRKT-MTG, GRIP, W2W, RH, INBOARD
5	552125	2	BRKT-MTG, GRIP, W2W, LH/RH, LOWER
6	100062	4	WSHR, FLAT, 3/8", .438 ID X 1.00 OD X .083" THK
7	100181	4	NUT, SERR FLG, HEX, 3/8-16 UNC, ZP
8	100040	4	SCR-HEX HD, 3/8-16 X 1.0" UNC, ZP
9	101320	12	BLT-CRG, 1/4-20 X 1.00", SST, BLK, EM6219
10	101370	12	WSHR-FL, SST, .281 X .625 X .065
11	102366	12	NUT-FLG, HEX, 1/4-20, SST
12	102549	12	SCR-HEX HD, M8 X 1.25 X 25mm, ZP
13	100034	12	WSHR-FL, 5/16, ZP
14	105859	6	NUT HEX-FLG, M8 X 1.25, ZP
15	553012	6	T-BOLT WELDMENT, ZP, 571632
16	101572	6	BOLT RETAINER-PLASTIC, 8mm

SERVICE PARTS LIST

BRACKET NO. - 401438

INSTALLATION ON ROCKER PANELS WITH THREADED INSERTS

Fig. 1

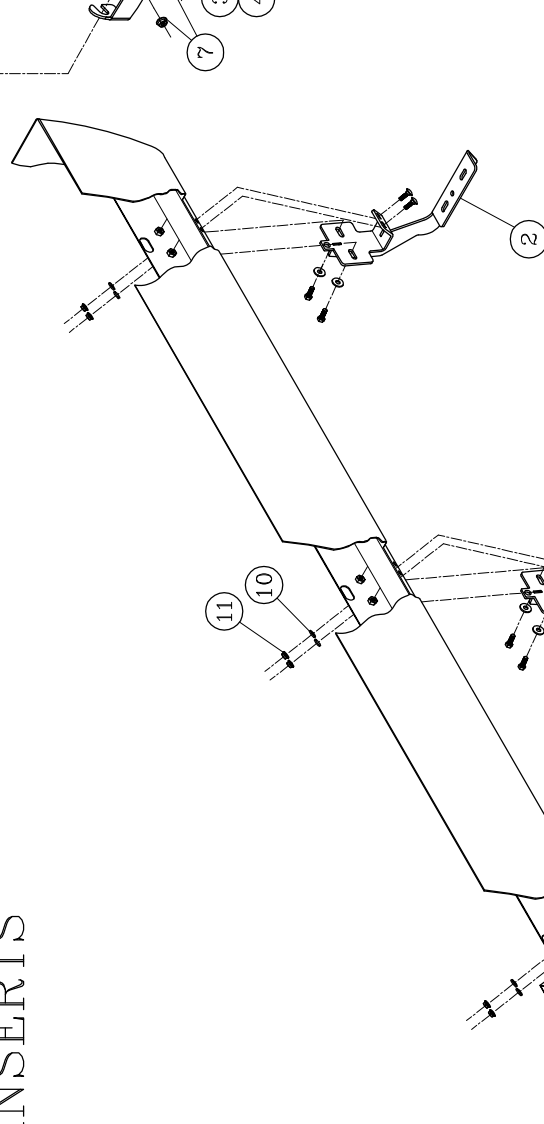
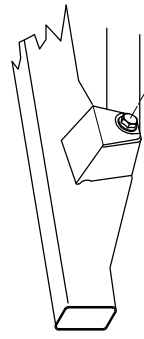
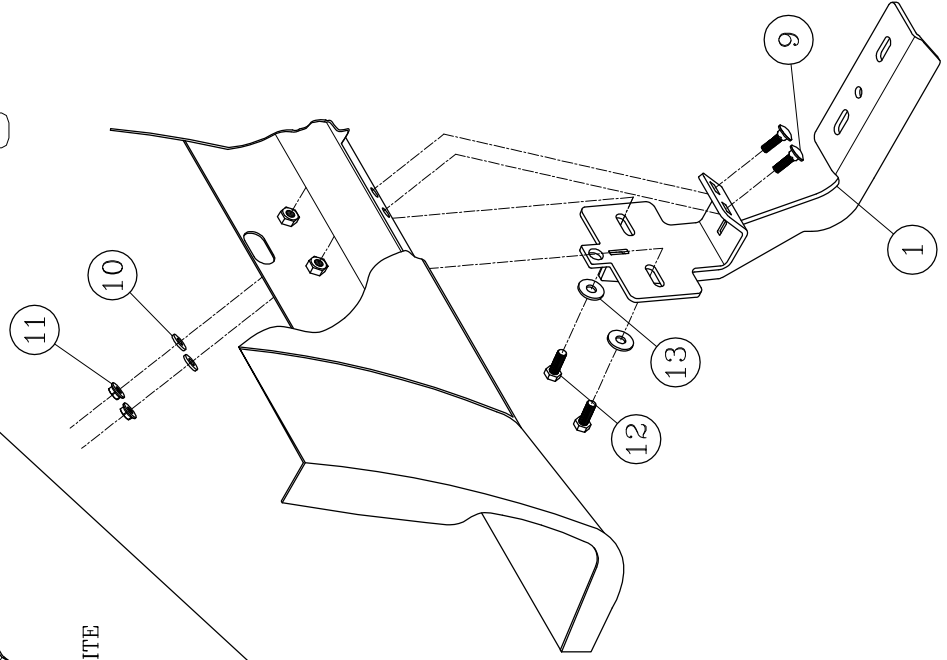

Fig. 2



LEFT (DRIVER) SIDE SHOWN
-RIGHT (PASSENGER) SIDE OPPOSITE-



SERVICE PARTS LIST

BRACKET NO. - 401438

INSTALLATION ON ROCKER
PANELS WITHOUT
THREADED INSERTS

Fig. 3

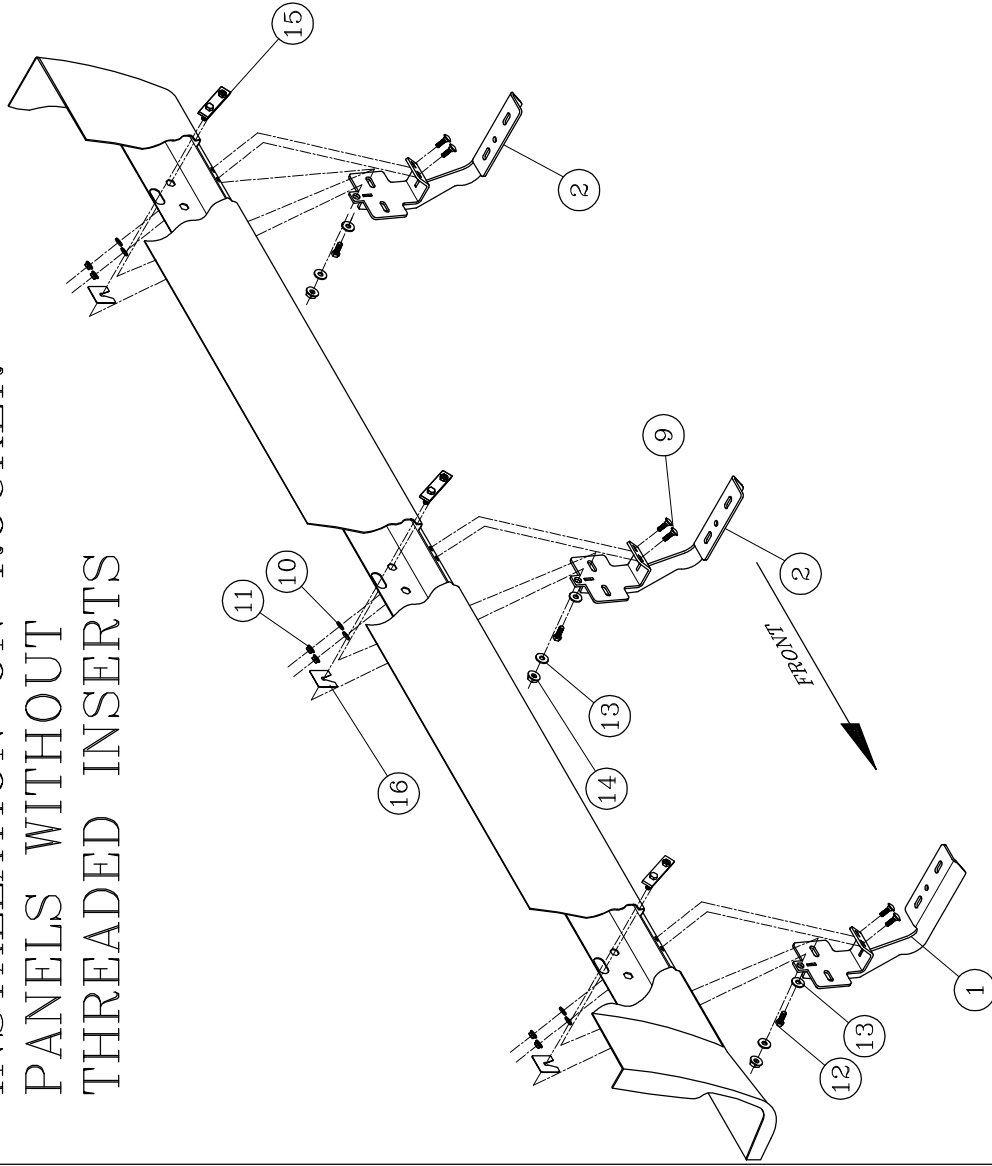
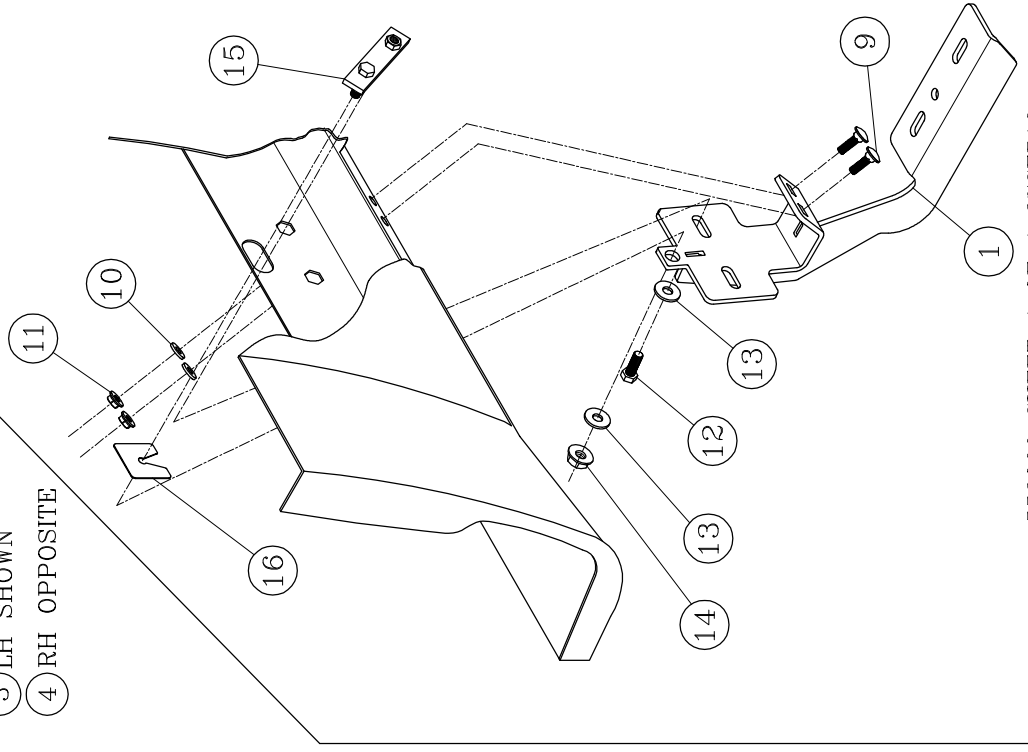

Fig. 4



LEFT (DRIVER) SIDE SHOWN
-RIGHT (PASSENGER) SIDE OPPOSITE-

