



ECHO® IN-LINE TRAILER BRAKE CONTROLLER INSTALLATION MANUAL

51200

TABLE OF CONTENTS

Controls & Components	page 1
Before You Begin	page 2
Wiring Diagram	page 2
Mounting the Main Module	page 3
Initial Setup	page 4
Application Setup	page 5
Test Drive & Adjustment	page 7
Condition Notifications	page 8
Bench Test	page 10
Troubleshooting Guide	page 11

NOTICE

This device contains license-exempt transmitter(s) / receiver(s) that comply with Innovation, Science and Economic Development Canada's license-exempt RSS(s). Operation is subject to the following two conditions:

1. This device may not cause interference.
2. This device must accept any interference, including interference that may cause undesired operation of the device.

CONTROLS & COMPONENTS

1. Main module
2. Main module adhesive pad
3. Wiring harness
4. (6) 6" Zip ties
5. (2) 14.5" Zip ties
6. (4) Self-tapping screws

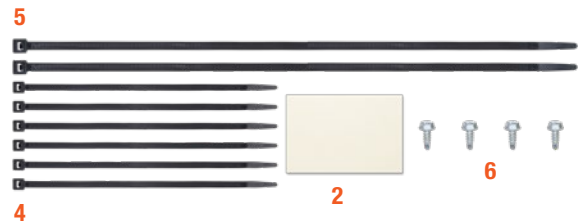

BEFORE YOU BEGIN

One or more of the following may be needed to complete the installation:

ⓘ ⚠ IMPORTANT: Read and follow installation manual carefully. Failure to do so could result in damage to the brake control unit, loss of trailer brakes or poor brake performance.

Disconnect the electrical plug between the trailer and tow vehicle before testing a breakaway switch. Failure to disconnect may damage the brake control unit.

⚠ WARNING The main module must be mounted firmly in place. Failure to do so could lead to improper operation and / or brake failure.

This product IS NOT compatible with Apple CarPlay or Android Auto, however, it will not interfere with these features.

This product is designed to provide a Bluetooth connection, without obstructions, up to 50 ft. connection may also be limited by the Bluetooth signal of your device.

WIRING DIAGRAM

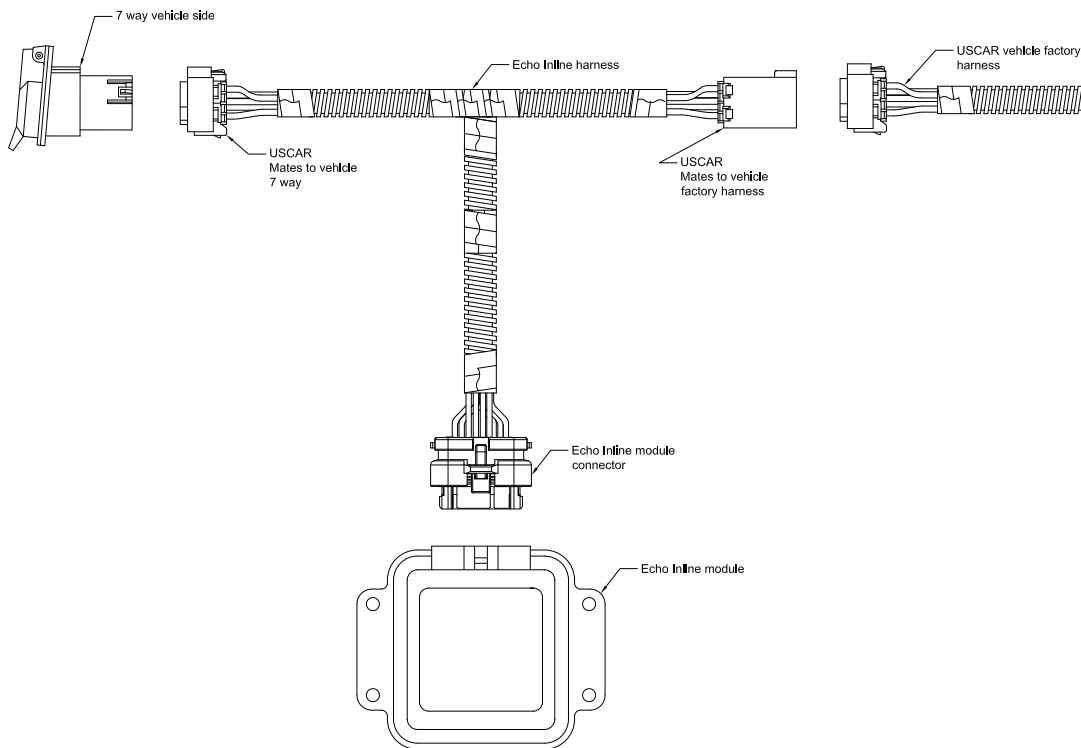

MOUNTING THE MAIN MODULE

1. Locate the vehicle 7-way electrical trailer connection at the rear of the vehicle.



2. Some 7-way electrical connections need to be accessed from the rear of the connector or behind the vehicle bumper. The USCAR connection point has a light grey external lock. Slide the lock to the rear or towards the wires to enter the 7-way. (The lock can be completely removed from the USCAR plug.)

NOTICE Not all vehicles will have this lock depending on the year, make and model



3. Push the USCAR plug in towards the 7-way while pressing the connector lock until you feel a click, and then pull out or away from the 7-way on the USCAR connector.

NOTICE The age and use of the vehicle can cause this connection to be harder to remove than other vehicles.

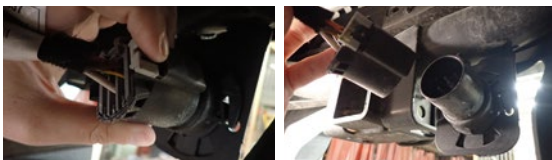

4. Install the T end of the harness in between the USCAR factory wiring harness and the vehicle 7-way. Then install the Echo in-line harness connection into the main module port.

NOTICE You may notice the Echo in-line will start blinking. This means that the vehicle has 12-volt power to the 7-way at all times and can be disregarded. Some vehicles must be started and others will need to have a trailer connected. Before the 12-volt power is turned on, secure the trailer to the electrical connector at the rear of the vehicle and tap the brakes to turn on the trailer tow mode.

5. Locate a suitable mounting location for the Echo in-line unit that is sheltered from road debris. Clean all dirt and debris from the mounting surface. Using the double-sided adhesive, apply the Echo in-line to the mounting surface. Use the self-tapping screws or the provided zip ties to firmly secure the Echo unit to the mounting surface.

NOTICE The Echo in-line can be mounted in any orientation, but it must be mounted in a solid location so no movement between the unit and the mounting surface can be felt.

CAUTION Check for miscellaneous items that may be hidden behind or under any surface before using self-tapping screws to avoid damage and / or personal injury

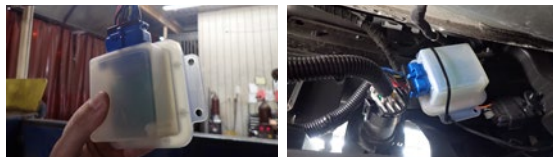

6. Using the provided zip ties, secure any excess wire harness and factory wiring to prevent snags and / or unwanted wear on electrical items.

DOWNLOAD THE MOBILE APPLICATION

Mobile applications are available for Apple and Android OS. They can be accessed in the App Store or Google Play by scanning the respective QR code below or searching for 'Echo® Smart Control'.

- Apple OS Requires IOS 5 or higher
- Android OS requires Android 4.3 or higher
- Bluetooth must be enabled on your device for pairing to occur
- After the app is installed, follow the prompts for setup



INITIAL SETUP FOR BLUETOOTH CONNECTION

NOTICE The vehicle needs to be running or the ignition in the 'ON' position with the vehicle in park.

NOTICE At any moment during setup, if the LED on the Echo in-line is red or a warning screen appears on your device, stop and refer to the 'Troubleshooting Guide'.

1. Enable Bluetooth in your mobile device settings.

NOTICE **DO NOT** pair the Echo® in-line through your phone's Bluetooth menu. Bluetooth connection will be done through the app in step 3.

2. The Echo® under-dash is ready to pair with the mobile application.

3. Launch the app and scan for the Echo under-dash. Once the 'Echo Brake Controller' is visible, select it. You will then be prompted to enter the six-digit PIN, found under the cap of the brake controller unit or on the provided quick reference card. Once pairing is complete, the LED light will be solid blue.

4. Plug the trailer's 7-way connector into the vehicle's 7-way connector while parked on a level surface. The LED light on the Echo under-dash will flash yellow for five to eight seconds while calibration occurs. Once the device is calibrated the LED will turn solid green.

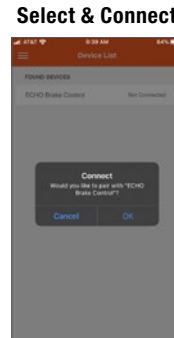
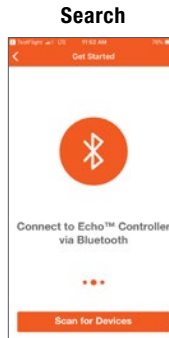

APPLICATION SETUP

After pairing with the Echo®, you will be directed to the 'Towing Profiles' screen to setup your trailer's profile. You can create and save profiles for multiple vehicles, trailers and load conditions.

Note: Setting configuration is required when trailer conditions change or the brake controller is being used for a different trailer or vehicle.

Within the 'Towing Profiles' screen, there are two different profiles menus for you to access.

1. Controller Profile

- In this menu, you can access the five most recently used settings. These settings are stored within the Echo device.
- Your active profile will display at the top of the menu (1A)

2. Application Profile

- In this menu, you can create an unlimited number of vehicle trailer profiles. These profiles are stored within the app on your phone.

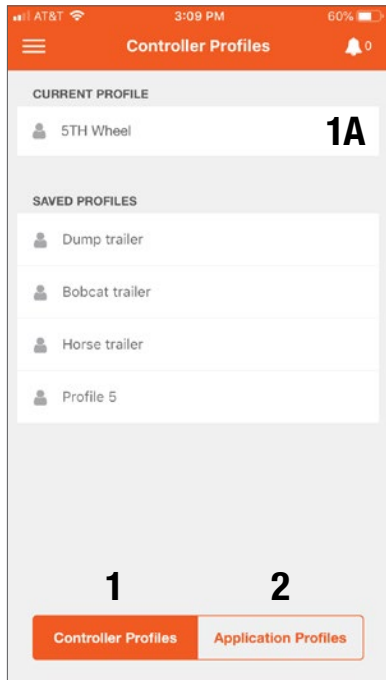

ADDING A PROFILE

1. On the 'Controller Profiles' menu, select the empty 'Current Profile' seat at the top of the menu.
2. Name the profile with descriptive information about the trailer you're towing.
3. Click 'Done' to confirm. You will then be directed to the 'Active Profiles' menu to begin set-up and adjustment.
4. You are also able to modify an existing trailer name by swiping left on the profile.
5. Repeat steps 1 – 3 for additional trailers (up to five saved on the device).

Create Profile

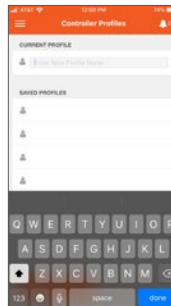

Edit Profiles

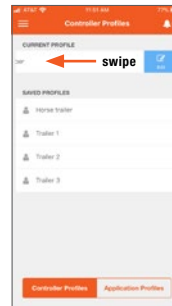

To create additional profiles, 6 or more, access the 'Application Profiles' section. This menu will allow you to create and store an unlimited number of profiles within the app. Select 'Add Profile' to begin and repeat steps 1 – 3.

ACTIVATING A PROFILE

1. Click on a profile you would like to activate.
2. Follow the screen prompt by selecting 'Ok'.
3. The profile you selected is now the active 'Current Profile'.

DELETING A PROFILE

1. In the 'Application Profiles' menu, select the profile you would like to delete.
2. Swipe left to open menu option.
3. Select 'Delete' to remove.

CONFIGURING PROFILE SETTINGS

In your 'Active Profile' screen you can adjust settings.

1. Manual Brake Activation

Activate manual braking, press and hold the orange button.

Manual brake controller activation is used in situations where a slow reduction in speed is desirable. As the manual control is activated, the Echo® begins to apply the trailer brakes. Manual output can be activated by pressing and holding the orange button in the app.

2. Brake Output Indicator

The blue ring indicates current brake output level.

The blue ring is a visual indicator of the current level of power being applied to the trailer brakes. When the vehicle's brakes are fully applied, the level of power and position of the ring is determined by your Max Output setting.

3. Max Output

The maximum level of the brake controller.

The output control establishes the max amount of power available to the trailer brakes when braking. The output should be adjusted during initial setup, when trailer load changes, when different trailers are used or when adjustment is needed for changing road or driving conditions.

4. Sensitivity Level

The sensitivity of the braking power.

The sensitivity level adjusts trailer aggressiveness when activated during braking. Sensitivity adjustment has no effect on the manual brake controller. The sensitivity can be adjusted for individual driver preference, trailer load changes or changing road conditions.

5. Screen Theme

Change from light to dark.

Under the 'Settings' menu, the option to change for day or night driving situations or application preference is available.

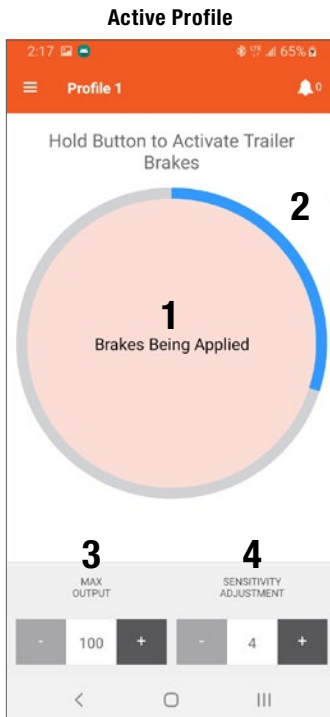

Screen Theme



TEST DRIVE & ADJUSTMENT

Both the output and sensitivity can be adjusted to achieve smooth, firm stops. Output and sensitivity adjustments should only be made while stopped, with the transmission in park or neutral, parking brake applied, foot off the brake pedal, and no manual control actuation. **Note:** Perform the adjustments in a safe environment with minimal vehicle traffic.

Starting with the output adjustment, drive forward on a dry and level paved or concrete surface. At approximately 25 mph, apply the vehicle's brakes. If trailer braking is insufficient, increase the max output setting in the brake controller application. If the trailer brakes lock up, decrease the max output. Repeat this process until stops are firm, just short of lock up.

Once the output is set, adjust the sensitivity by driving forward at approximately 25 mph and press the brake pedal. The vehicle and trailer should make a smooth stop. If the stop seems slow and more aggressive braking is desired, increase the sensitivity level through the brake controller application. If the stop seems too aggressive, decrease the sensitivity level in the application.

Make several stops at various speeds and adjust the sensitivity until stops are smooth and firm. Slight adjustment to the output control may also be desirable. **Note:** If any problems occur during setup, refer to the 'Troubleshooting Guide' on the last page of this manual.

LED STATUS INDICATOR

A single LED on top of the Echo® shows the status of the brake controller unit. Refer to the icons and descriptions below.



Device not paired,
no trailer connected
(flashing blue)



Device paired,
no trailer connected
(solid blue)



Calibrating
Echo®
(flashing yellow)



Device not paired,
trailer connected
(flashing green)



Device paired,
trailer connected
(solid green)



Wiring error
(flashing red)



Hardware fault
(solid red)



No power
(no light on)

Indicator	Status
Flashing blue	Device not paired, no trailer connected
Solid blue	Device paired, no trailer connected
Flashing yellow	Calibrating Echo
Flashing green	Device not paired, trailer connected
Solid green	Device paired, trailer connected
Flashing red	Wiring error
Solid red	Hardware fault

CONDITION NOTIFICATIONS

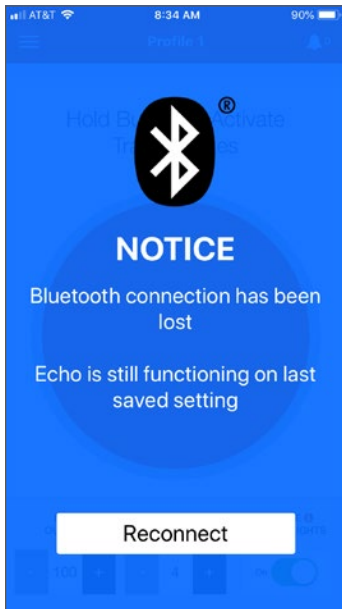

NOTICE If a communication error occurs between the mobile application and the brake controller, the 'Manual Brake Activation', 'Max Output' and 'Sensitivity Level' cannot be adjusted and condition notifications from the brake controller will not be sent. The brake controller will continue to function properly at the most recently programmed settings and braking operation will not be affected.



DANGER If the trailer 7-way has become disconnected from the vehicle a warning will pop up on your screen. Safely stop the vehicle and reinstall your connection. Once connections has been restored, the application will resume with the most recently programmed settings.

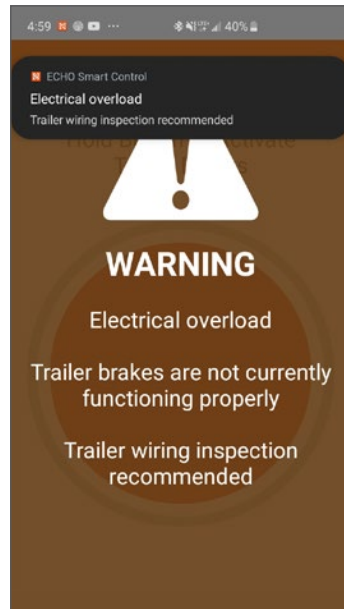

WARNING If the Echo® detects an overload to the trailer brakes a warning will pop up on your screen. Safely stop the vehicle, disconnect and reconnect the trailer 7-way. If the message reappears, a trailer wiring inspection is recommended.

CONDITION NOTIFICATIONS



⚠️ WARNING If the Echo® detects an overload to the trailer lights a warning will pop up on your screen. Safely stop the vehicle, disconnect and reconnect the trailer 7-way. If the message reappears, a trailer wiring inspection is recommended.

BENCH TEST

Parts Needed:

1. Curt 7 way tester – Curt #58272 / 58273

Step 1: Install the Echo in-line per the "mounting the module" section. Install the Curt tester into the vehicle 7 way, follow the scenario that applies to your vehicle.

Scenario A: Tester 12V Purple light is illuminated

Scenario B. Tester no lights are illuminated

Scenario B1. Start the vehicle

Scenario B2. Tester 12V Purple light is illuminated

Scenario C. Tester no lights are illuminated

Scenario C1. Start the vehicle

Scenario C2. Tester no lights are illuminated

Scenario C3. Press the vehicle brake pedal

Scenario C4. Tester 12V Purple light is illuminated

Step 2: Using your Bluetooth device follow the Echo App "Initial setup for Bluetooth connection" and select any profile you have saved or "Profile 1" if no custom profiles have been created.

Step 3: At the Active Profile screen, press the Manual Brake activation. This will illuminate the BK or Blue light on the tester showing that the Echo is activating the trailer brake wire.



TROUBLESHOOTING - CONNECTING ECHO® UNIT TO THE APP

1. If you see the following error notification: 'Error in Connection: No Device Found', verify distance (see bottom of page 2) and check your unit for a blinking light. If the unit does not show a blinking light, check the connection and / or fuse for trailer brakes per owner's manual.

Selecting 'Stop connecting' will cancel the connection process.

2. Selecting 'Reconnect' will attempt to reconnect to the last Echo used. If you use multiple Echo units, resetting the device allows you to clear the Bluetooth cache and connect to the unit you wish. In order to connect, the Echo unit needs to be connected to a power supply. Some vehicles will not have power until they are running.

The Echo unit must be within the Bluetooth range for the app to connect.
None of the trailer profile setting will be changed upon resetting the Bluetooth cache.

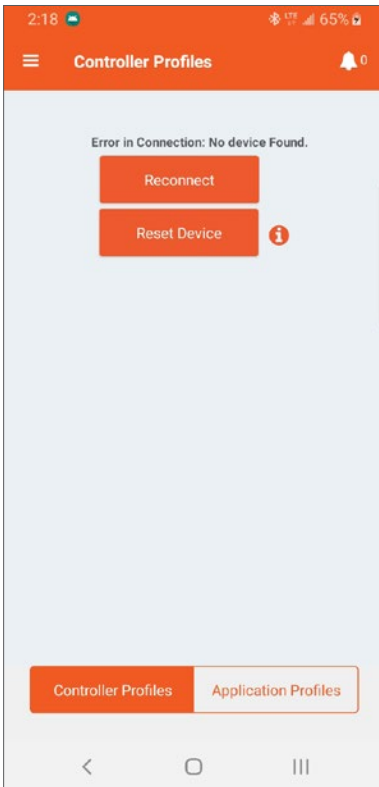
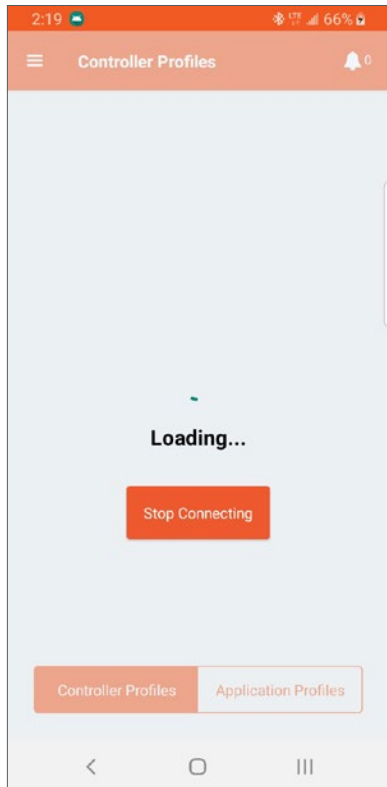

IN-APP INSTALLATION MANUAL

The instruction manuals for the Echo® unit and the manual override button are available to access within the Smart Control app. Select the menu icon in the top left of the app, and then select 'Instructions and User Guides'. From this screen, you can select which instruction manual you would like to view.

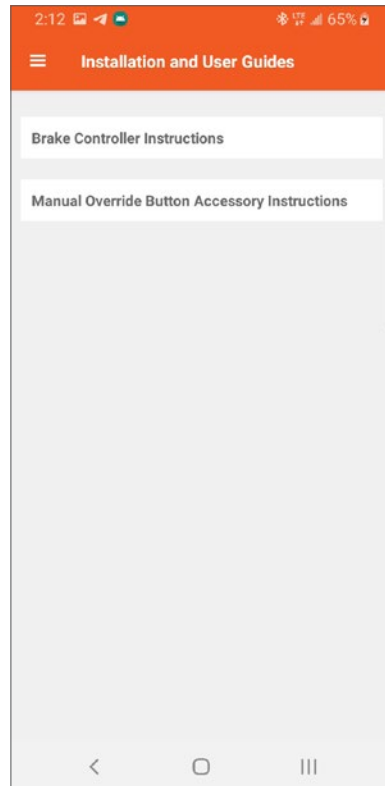
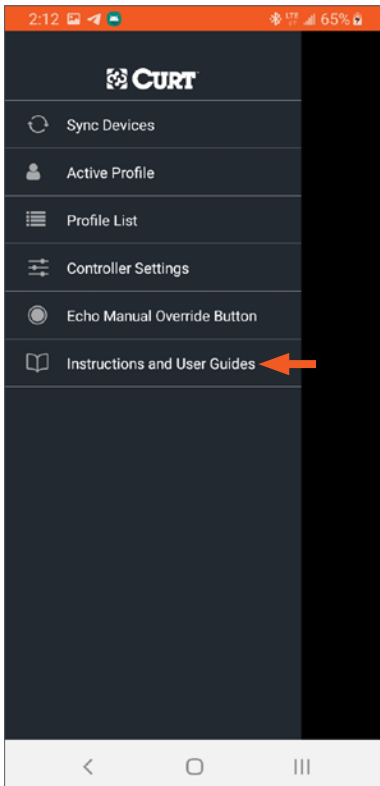
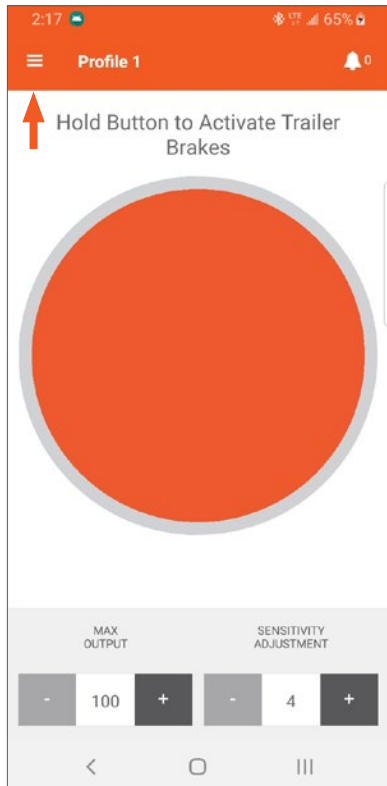

TROUBLESHOOTING GUIDE

Condition	Problem Cause	Possible Solution
LED does not light	No power to brake controller, no ground on vehicle 7-way Trailer mode not activated for vehicle	Check vehicle power and ground wiring Check fuse for towing power wire Tap brakes after CURT #58272 / #58273 tester or trailer is installed to activate trailer tow mode Vehicle requires trailer to activate 7-way power
Unable to connect to mobile devices	No power to brake controller, no ground on vehicle 7-way Invalid Bluetooth PIN Bluetooth cache needs to be reset	Check Echo LED status for power Input PIN from label or quick reference card Enable Bluetooth or grant permissions Check smartphone compatibility To reset bluetooth cache, go to the device list at the bottom and select 'Reset Device'- This will not effect previous profile settings, it will only effect the Smart Control app log in
Solid red LED for more than 10 seconds	Hardware fault	Contact CURT Product Support
Flashing red LED	Contamination in trailer plug socket	Check for clean and dry trailer plug
	Short in trailer brake wiring	Locate and correct short
	Accelerometer error	Unplug the brake controller and plug it back in
	Short or overload in trailer brakes	Troubleshoot trailer brake circuit per brake manufacturer's instructions
No trailer brakes, pedal or manual	Mis-wired 7-way connector Improper or corroded trailer wiring Weak or missing ground	Confirm vehicle and trailer 7-way connections
No trailer brakes, pedal or manual (device notification of error)	Loss of trailer connection, unplugged or bad wiring	Confirm vehicle and trailer 7-way connections
No response on manual override or brake output	Mis-wired 7-way connector Improper or corroded trailer wiring No or intermittent power to brake controller Weak or missing ground Wireless connectivity error	Confirm vehicle and trailer 7-way connections Check Bluetooth and application settings
Reduced braking power on manual override or brake output	Weak or missing ground Improper max power or sensitivity settings Improper or corroded trailer wiring	Confirm vehicle and trailer 7-way connections Check Bluetooth and application settings Increase max power or sensitivity settings
Trailer brakes on all the time (LED shows red)	Mis-wired 7-way trailer connector	Confirm vehicle and trailer 7-way connections
App signals 'low voltage'	Low battery voltage	Check vehicle battery and replace if needed Confirm vehicle 7-way connections and wiring
App signals a 'disconnect'	Trailer connector is disconnected	Reconnect the trailer connector Confirm vehicle 7-way connections and wiring
App signals 'overload'	Trailer brakes are overloaded	Reconnect the trailer connector Confirm vehicle 7-way connections and wiring Check trailer brake wiring for short circuits

PRODUCT REGISTRATION

CURT stands behind our products with industry-leading warranties. To get copies of the product warranties, register your purchase or provide feedback, visit: warranty.curtgroup.com/surveys

LET US KNOW WHAT YOU THINK!

Share the love and your experience with Echo by leaving a review on curtmfg.com/51200.

