

88-99 GM TRUCK / 92-99 SUBURBAN, TAHOE, YUKON MUD GUARD FRONT/REAR WITH FENDER FLARES - INSTALLATION INSTRUCTIONS

(see other side for vehicles with out fender flares)

Please read instructions thoroughly before installation.

Tools Required:

- 1/8" drill bit / Drill
- Center punch / Hammer
- Short Phillips screwdriver or drill attachment
- Marking utensil (fine tip marker, grease pencil, etc.)

Package Contents

- Driver (LH) & passenger (RH) side mud guards
- #10 screw (qty. 6)
- Instruction sheet

NOTE: Turn the front wheels all the way to the left or right for front mud guard installation. It may be necessary to remove the rear wheels for rear mud guard installation.

FRONT FENDER

1. Clean and degrease the mud guard location area on the front fender before installation.
2. Remove existing fastener from location G and attach mud guard with existing fastener at location G (Figure 1), check fit and alignment before tightening.
3. Using mud guard as a template, center punch, drill 1/8" holes at locations D & E (through mud guard) and F and fasten with #10 screws.

REAR FENDER

1. Clean and degrease the mud guard location area on the rear fender before installation.
2. Remove existing fastener from location F and attach mud guard with existing fastener at location F (Figure 2), check fit and level before tightening.
3. Using mud guard as a template, center punch, drill 1/8" holes at locations D & E (through mud guard) and G and fasten with #10 screws.

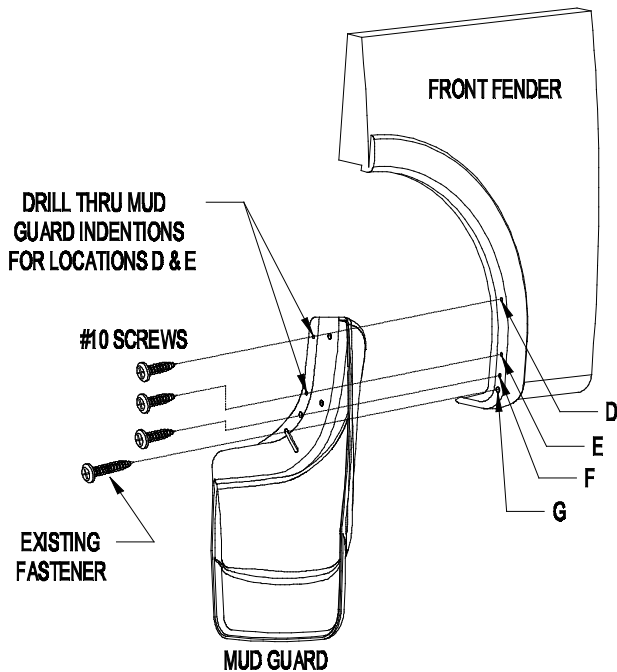

Figure 1

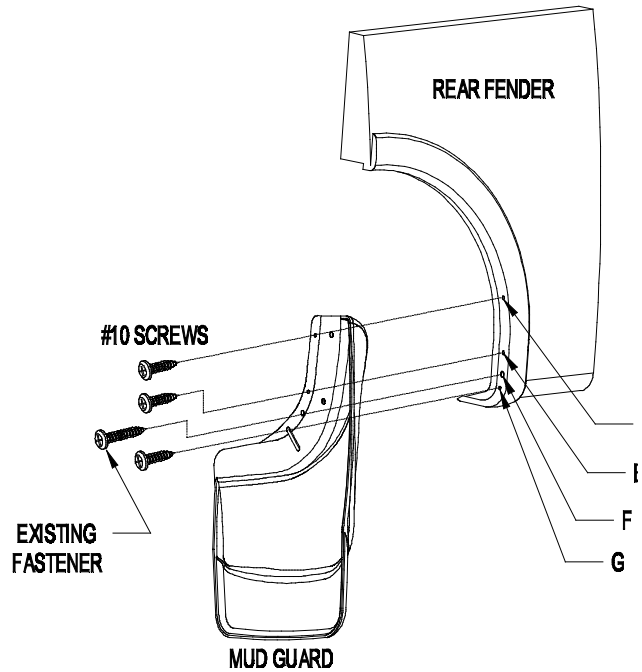

Figure 2

PAINTING INSTRUCTIONS

1. Clean mud guard with a soap and water solution to remove dirt and other contaminants.
2. Sand painting surface with 320 grit sand paper.
3. Apply a coating of flexible primer-adhesion promoter.
4. Apply a flexible paint as directed by the paint manufacturer

88-99 GM TRUCK, 92-99 SUBURBAN, TAHOE, YUKON FRONT/REAR MUD GUARD WITHOUT FENDER FLARES - INSTALLATION INSTRUCTIONS

(see other side for vehicles with fender flares)

Please read instructions thoroughly before installation.

Tools Required:

- 1/8" drill bit / Drill
- Center punch / Hammer
- Short Phillips screwdriver or drill attachment
- Marking utensil (fine tip marker, grease pencil, etc.)
- Cutting tool (box knife, etc.)

Package Contents

- Driver (LH) & passenger (RH) side mud guards
- #10 screw (qty. 6)
- Instruction sheet

NOTE: Turn the front wheels all the way to the left or right for mud guard installation. However, it may be necessary to remove the rear wheels depending on the tools being used for installation.

4. Clean and degrease the mud guard location area on the fender before installation.
2. Remove mounting flange extension by trimming along cut line (Figure 2) VEHICLES WITHOUT FENDER FLARES ONLY.
3. Using mud guard as a template mark location B on fender, center punch, drill 1/8" hole, and fasten mud guard to fender with a #10 screw (Figure 1). Check fit and level before tightening.
4. Center punch, drill 1/8" holes at locations A and C, and fasten with #10 screws.

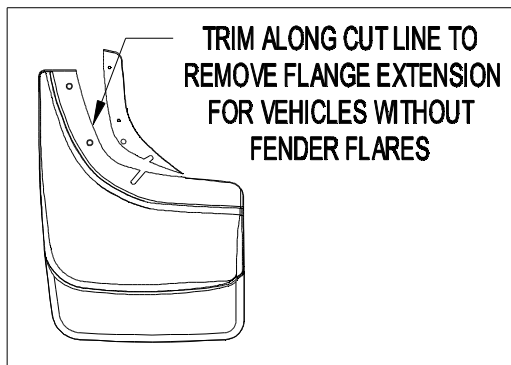

Figure 2

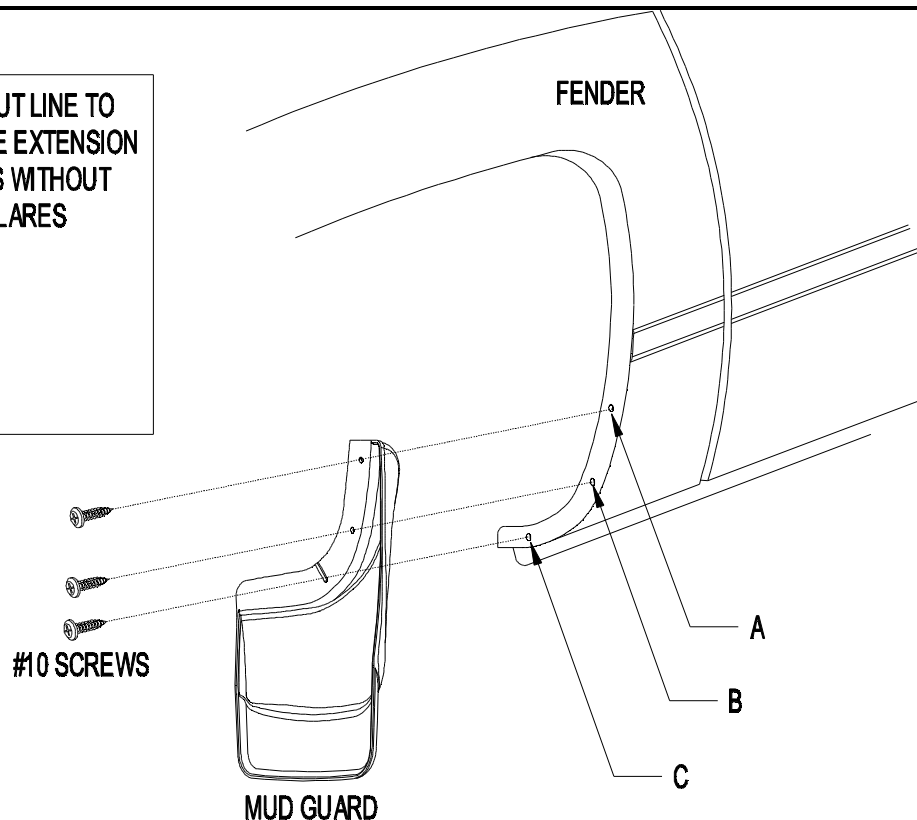

Figure 1

PAINTING INSTRUCTIONS

1. Clean mud guard with a soap and water solution to remove dirt and other contaminants.
2. Sand painting surface with 320 grit sand paper.
3. Apply a coating of flexible primer-adhesion promoter.
4. Apply a flexible paint as directed by the paint manufacturer