

LoadLifter 5000™ + Air Lift® ProSeries



Installation Guide



Toyota Tacoma



Watch the video

Info on Table of Contents page

Kit 57300 | 77300

For maximum effectiveness and safety, please read these instructions completely before proceeding with installation.

Failure to read these instructions can result in an incorrect installation.

Protect your Air Lift Purchase by Completing your Warranty Registration

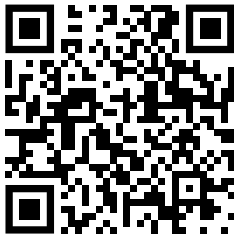

Thank you for purchasing an Air Lift load support product!

Take a photo of your sales receipt and then scan the QR code to complete your online warranty registration.

TABLE OF CONTENTS

2 System Overview

3 Hardware and Tools

4 Introduction

Notation Explanation

5 Installing the System

Prepare the Vehicle
Assemble and Install the Air Springs

10 Installing the Air Lines

Installing Nylon Air Lines

11 Finishing the Installation

12 Before Operating

Installation Checklist
Maintenance and Use Guidelines

13 Limited Warranty and Return Policy

Video-enhanced installation guides

Visit airliftcompany.com/workshop/category/install-videos to access our installation video archive*.

System Overview

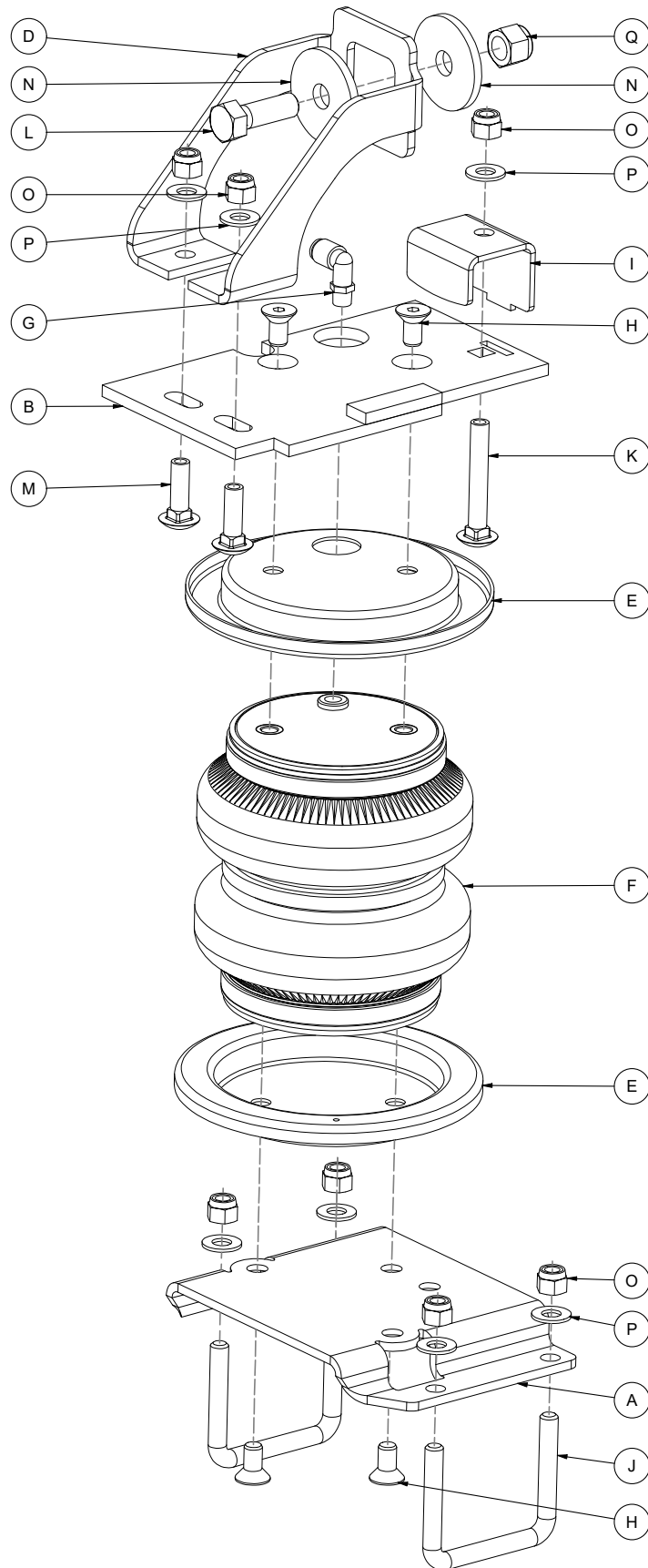

Driver's (left) Side

Fig. 1

Hardware and Tools

HARDWARE LIST

| Item | Part# | Description | Qty |
|------|-------|---|-----|
| A | 03053 | Lower bracket | 2 |
| B | 07511 | Upper LH bracket | 1 |
| C | 07518 | Upper RH bracket | 1 |
| D | 11190 | Inner brace | 2 |
| E | 11951 | Roll plates | 4 |
| F | 58439 | Air springs | 2 |
| G | 21837 | 1/4" 90 degree Swivel air fitting | 2 |
| H | 17215 | 3/8"-16 X 3/4" Flat head socket-cap screw | 8 |
| I | 11189 | Clamp bar | 2 |
| J | 11522 | U-bolt | 4 |
| K | 17141 | 3/8"-16 X 2 1/2" Carriage bolt | 2 |
| L | 17161 | 1/2"-13 X 1 1/2" Hex-cap screw | 2 |
| M | 17361 | 3/8"-16 X 1 1/4" Carriage bolt | 4 |
| N | 18207 | 17/32" X 2" X 3/16" Large flat washer | 4 |
| O | 18435 | 3/8"-16 Nylon lock nut | 14 |
| P | 18444 | 3/8" Flat washer | 14 |
| Q | 18460 | 1/2"-13 Nylon lock nut | 2 |
| R* | 18442 | 3/8" Pin spacer | 3 |
| AA* | 20086 | Air line assembly | 1 |
| BB* | 10466 | Zip ties | 6 |
| CC* | 18411 | 5/16" Lock washer | 2 |
| DD* | 21234 | Rubber washer | 2 |
| EE* | 18501 | M8 Flat washer | 2 |
| FF* | 21233 | 5/16" Hex nut | 4 |
| GG* | 21230 | Valve cap | 2 |

* These parts are not shown in the System Overview (Fig.1).

TOOLS NEEDED

| Description | Qty |
|---|-------|
| Standard and metric open-end or box wrenches | Set |
| 9/16 Ratchet wrench | 1 |
| Ratchet | 1 |
| Standard and metric regular and deep-well sockets | Set |
| 7/32" hex-key wrench (socket preferable) | 1 ea. |
| Torque wrench | 1 |
| Box cutter or equivalent | 1 |
| Hose cutter, razor blade, or sharp knife | 1 |
| Hoist or floor jack | 1 |
| Safety glasses | 1 |
| Safety stands | 2 |
| Air compressor or compressed air source | 1 |
| Spray bottle with dish soap/water solution | 1 |



Missing or damaged parts? Call Air Lift customer service at (800) 248-0892 for a replacement part.

Introduction

The purpose of this publication is to assist with the installation and maintenance of the LoadLifter 5000 and Air Lift ProSeries air spring kits. All LoadLifter 5000 and Air Lift ProSeries kits utilize sturdy, reinforced, commercial-grade single or double convolute bellows depending on the kit.

The air springs are manufactured like a tire with layers of rubber and cords that control growth. LoadLifter 5000 and Air Lift ProSeries kits provide up to 5,000 pounds (2,268kg) of load-leveling support with air adjustability from 5-100 PSI (.34-7BAR).

It is important to read and understand the entire installation guide before beginning installation or performing any maintenance, service or repair.

NOTATION EXPLANATION

Hazard notations appear in various locations in this publication. Information that is highlighted by one of these notations must be observed to help minimize risk of personal injury or possible improper installation, which may render the vehicle unsafe. Notes are used to help emphasize areas of procedural importance and provide helpful suggestions.



DANGER

The following definitions explain the use of these notations as they appear throughout this guide.

INDICATES IMMEDIATE HAZARDS WHICH WILL RESULT IN SEVERE PERSONAL INJURY OR DEATH.



WARNING

INDICATES HAZARDS OR UNSAFE PRACTICES WHICH COULD RESULT IN SEVERE PERSONAL INJURY OR DEATH.



CAUTION

INDICATES HAZARDS OR UNSAFE PRACTICES WHICH COULD RESULT IN DAMAGE TO THE VEHICLE OR MINOR PERSONAL INJURY.



NOTE

Used to help emphasize areas of procedural importance and provide helpful suggestions.

Installing the System

PREPARE THE VEHICLE

1. Lift the vehicle and support the frame with safety stands. Drop the axle down low enough to later set the air springs into position between the frame and axle (Fig. 2). Remove the rear wheels.

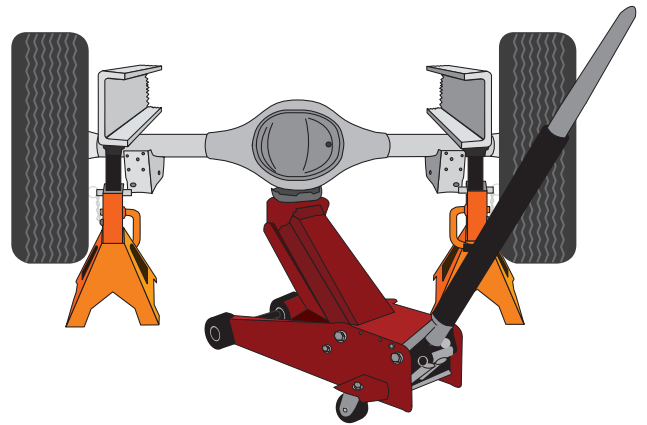

Fig. 2

2. Trim the stock jounce bumper to gain clearance for the air spring assembly's lower bracket. Measure up from the base 3/4" and mark a line on the jounce bumper. Using a box cutter or equivalent, cut the top of the jounce bumper off (Figs. 3 & 4).



USE EXTREME CAUTION WHEN CUTTING OFF THE JOUNCE BUMPER WITH THE CUTTING TOOL.



Fig. 3



Fig. 4

- There are (3) bolts located on top of the left (driver's) side frame above the axle, which hold the brake line bracket and wiring harness to the top flange of the frame. Remove these (3) bolts and set aside for re-use later in the installation (Fig. 5).

Fig. 5

- Install the inner frame braces (D) onto the inside of the frame rail using the 1/2" hex-cap screw (L) and large flat washer (N). Insert the screw/washer through the brace (Fig. 6), then through the large hole in the side of the frame above the axle. From the outside of the frame, install another large washer and 1/2" nylon lock nut (Q) over the hex-cap screw (Fig. 7). Draw the nut down, but do not tighten at this time. The inner frame brace must be able to move freely for the upper bracket to attach and align correctly.

NOTE For the driver's (left) side: Hold the unbolted brake line/wiring harness out of the way to install the brace more easily.

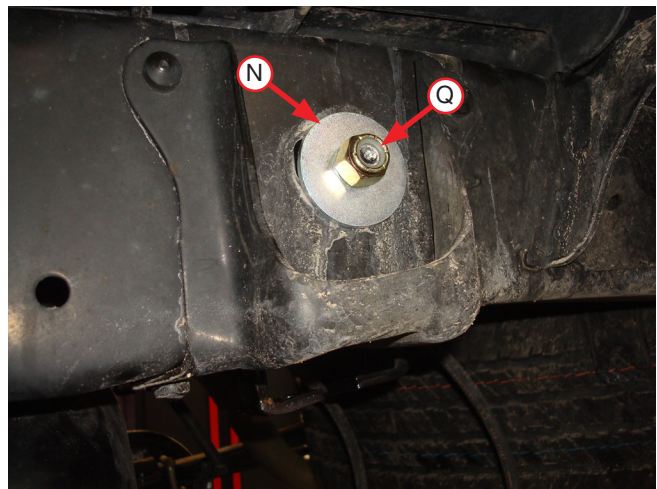
Fig. 6

Fig. 7

ASSEMBLE AND INSTALL THE AIR SPRINGS

1. Set a roll plate (E) over the top of the air spring (F). Install the swivel fitting (G) into the air port on the air spring. Tighten the fitting one and a half turns past finger-tight (Fig. 8).

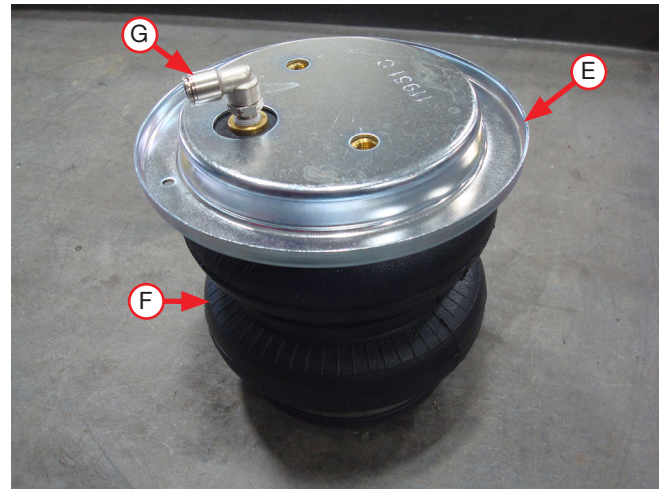

Fig. 8

2. Insert the 3/8" carriage bolts (K) through the bottom of the upper brackets (B & C), then set the brackets onto both air springs ensuring the welded-on spacer is facing up (Fig. 9). Attach with the 3/8" flat head screws (H). Torque the flat head screws to no more than 20 lb.-ft. (27Nm). Once complete, there is now a left (driver's) and right (passenger's) side assembly.

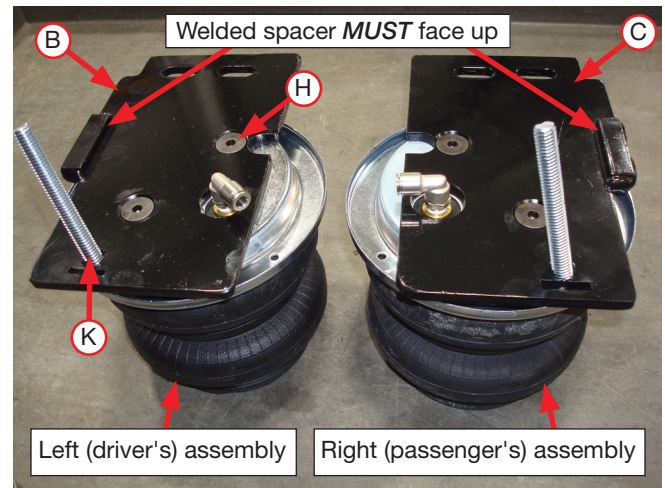
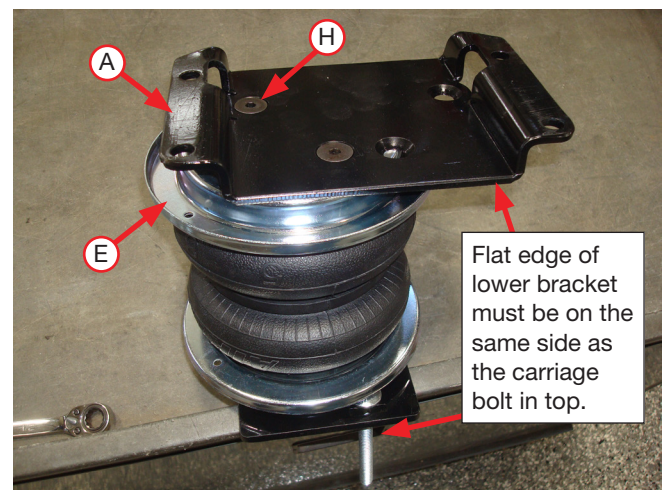

Fig. 9

3. Flip the left (driver's) side assembly upside-down being careful not to damage the fitting. Set a roll plate and the lower bracket (A) onto the air spring (Fig. 10), ensuring the flat edge of the bracket is on the same side as the carriage bolt on top. Make sure to use the left-hand side mounting holes in the lower bracket. Attach the lower bracket to the air spring with the 3/8" flat head screws (H) and torque to no more than 20 lb.-ft. (27Nm). Repeat for the right-hand side but use the right-hand side mounting holes in the lower bracket.



Left (driver's) side shown

Fig. 10

4. Figure 11 shows the left- and right-hand assemblies.
5. With the axle dropped, set the left- and right-hand assemblies onto the leaf spring, ensuring the fitting and the carriage bolt is facing outward. The fitting should be to the back of the axle and on the outside of the frame (Figs. 19 & 21). Once both assemblies are in place, raise the axle up so the upper bracket touches the frame.

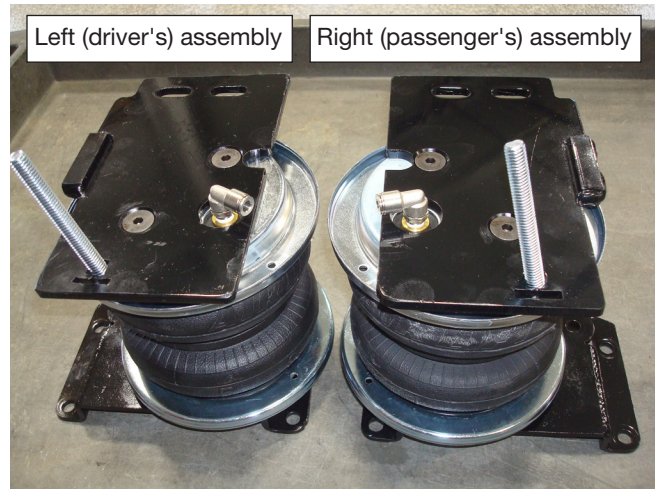

Fig. 11

6. Install the U-bolts (J) under the leaf spring and up through the lower bracket (Fig. 12). Cap with 3/8" flat washers (P) and nylon lock nuts (O). Leave loose at this time.

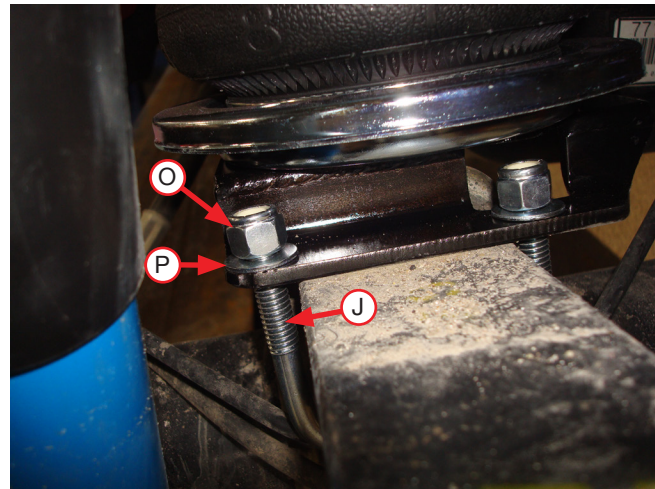

Fig. 12

7. Set the clamp bar (I) over the carriage bolt, ensuring the short edge fits over the stock jounce bumper strike plate bracket (on the frame). Also, ensure the tab on the clamp bar inserts into the small slot on the upper bracket (Fig. 13). Cap with a 3/8" flat washer (P) and nylon lock nut (O) finger-tight only at this time.

NOTE From inside the pocket, clean out any mud or debris so the clamp bar will fit flush with the jounce bumper bracket.

Stock jounce bumper bracket

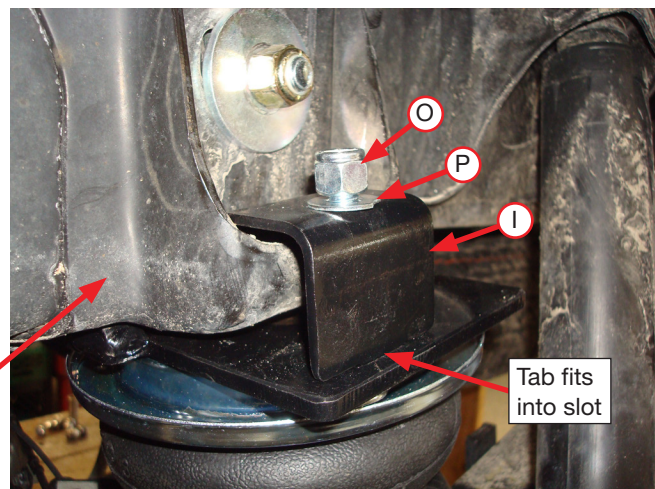

Fig. 13

8. On the inside of the frame, insert two 3/8" carriage bolts (M) up through the bottom of the upper bracket and through the inner brace (Fig. 14). Cap the bolts with two 3/8" flat washers (P) and nylon lock nuts (O). Ensure the welded piece on the front of the upper bracket touches the stock jounce bumper bracket all the way across where it comes in contact with it. Also, ensure the rear of the upper bracket is contacting the stock jounce bumper bracket. Adjust the inner brace by pulling it all the way back to the back side of the slots on the upper bracket. Tighten the nuts on the carriage bolts so they are snug, and repeat on the other side.
9. Snug the outer clamp bar carriage bolt while ensuring that the upper bracket is set against the stock jounce bumper bracket. Torque the 1/2" bolt on the inner frame brace to 35 lb.-ft. (47Nm). Finish by torquing the (3) 3/8" upper nylon lock nuts to 16 lb.-ft. (22Nm).
10. Evenly torque the exposed lower bracket U-bolts to 16 lb.-ft. (22Nm). Tighten the rear U-bolt using a 9/16" ratchet or open-end wrench.

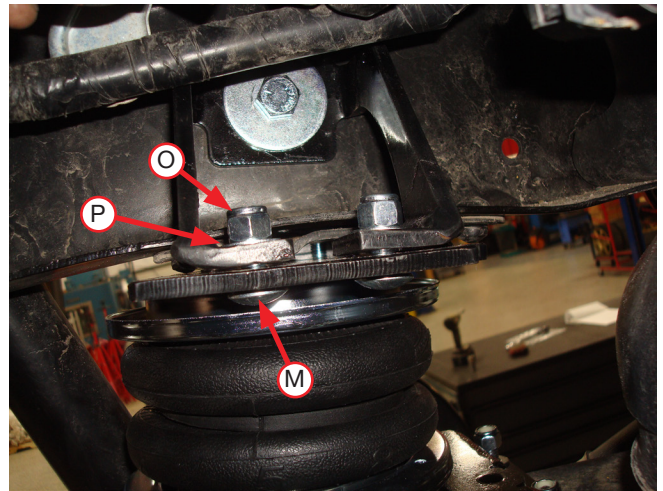

Fig. 14

NOTE

Some early models may have shorter leaf spring stacks and may require "trimming" the top of the U-bolt off, above the nylon lock nut on the rear, inside installation location. If the top of the U-bolt hits on the roll plate while tightening (Fig. 12), grind or hack saw off the excess above the nylon lock nut before completely tightening the nut.

11. Set the three pin spacers (R) under the brake line and wiring harness brackets where the three stock bolts were removed in Step 3 of the Prepare the Vehicle section. Re-install the bolts that were removed and tighten securely (Fig. 15).

NOTE

If the wiring harness on the inside of the frame is still touching the upper brace, push up on the wiring harness bracket and bend it to create enough clearance so the wiring harness will not chafe on it.

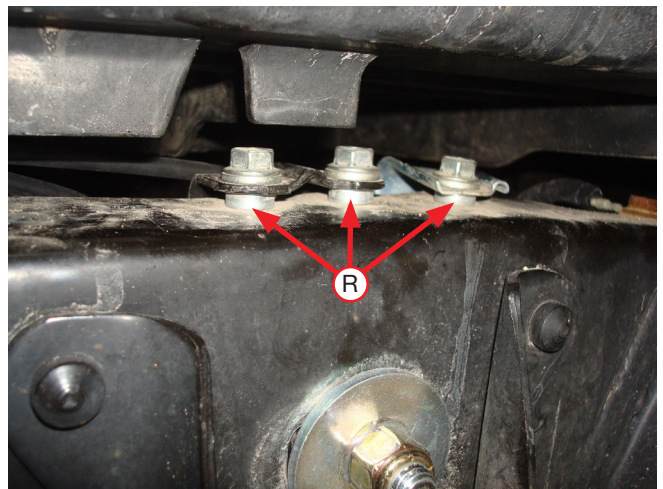

Fig. 15

Installing the Air Lines

1. Begin by choosing locations for the Schrader valves (Fig. 16) and drill a 5/16" (8mm) hole, if necessary.

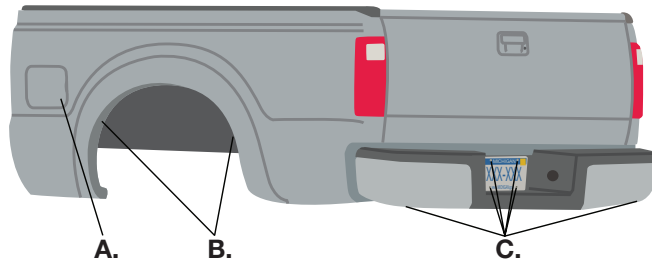

Fig. 16

- A. Inside fuel tank filler door B. Inside rear wheel wells C. License plate or rear bumper area



KEEP AT LEAST 6" (150MM) OF CLEARANCE BETWEEN ALL AIR LINES AND THE EXHAUST SYSTEM. AVOID SHARP BENDS AND EDGES.

2. Install the Schrader valve in the chosen location (Fig. 17).

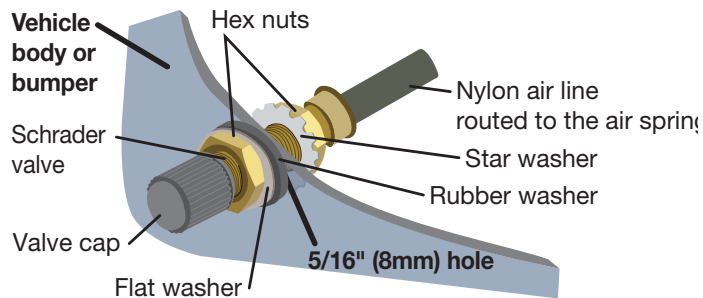

Fig. 17

INSTALLING NYLON AIR LINES

The nylon air lines are routed from the Schrader valves to the air springs.

1. It is recommended that the air line be routed along the top of the frame and then down to the fitting. After cutting the air line to length, insert it into the fitting.
2. Make clean, square cuts with a razor blade or hose cutter when cutting the air line. Do not use scissors or wire cutters. (Fig. 18)

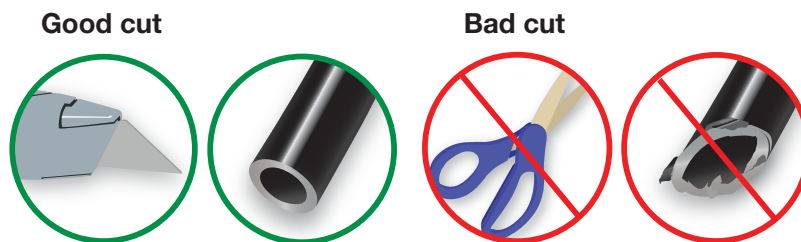

Fig. 18

3. Use zip ties (BB) to secure the air line to fixed points along the chassis. Do not pinch or kink the air line. The minimum bend radius for the air line is 1" (25mm). Leave at least 2" (50mm) of slack in the air line to allow for any movement that might pull on the air line.

Finishing the Installation

1. Install the wheels back onto the vehicle and in a crisscross pattern, torque the wheel nuts to factory specifications.

The images show the finished installation of both sides (Figs. 19, 20, 21 & 22).

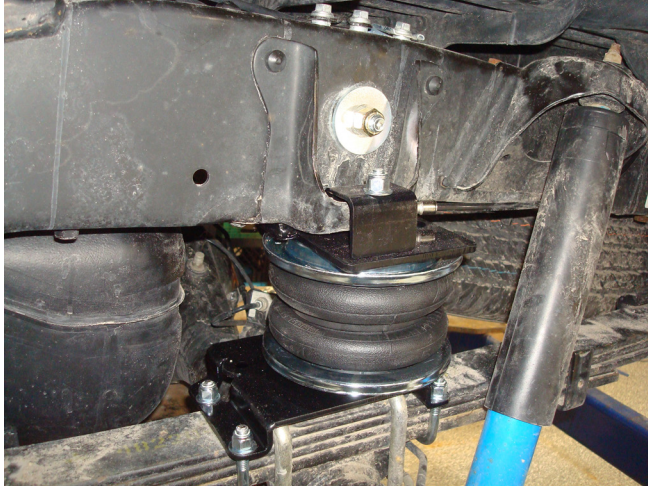

Outside, left (driver's) side view of installation. *Fig. 19*



Inside, left (driver's) side view of installation. *Fig. 20*

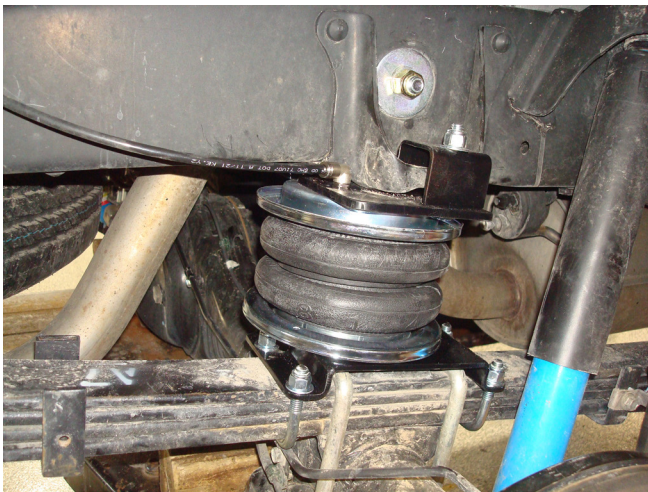

Outside, right (passenger's) side view of installation. *Fig. 21*

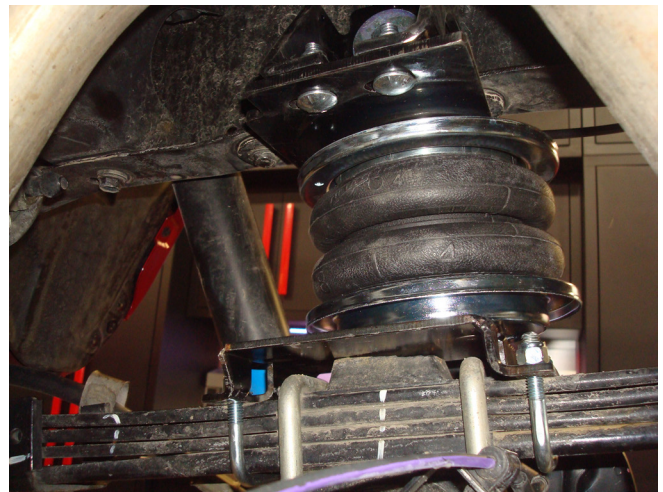

Inside, right (passenger's) side view of installation. *Fig. 22*

Congratulations!

You are now the proud owner of an Air Lift air suspension system. Enjoy!

Before Operating

INSTALLATION CHECKLIST

- ❑ **Clearance test** — Inflate the air springs to 40-60 PSI (2.8-4.1BAR) and make sure there is at least 1/2" (13mm) clearance from anything that might rub against each sleeve. Be sure to check the tire, brakes, frame, shock absorbers and brake cables.
- ❑ **Leak test before road test** — Inflate the air springs to 40-60 PSI (2.8-4.1BAR) and check all connections for leaks. All leaks must be eliminated before the vehicle is road tested.
- ❑ **Heat test** — Ensure sufficient clearance from heat sources, at least 6" (152mm) for air springs and air lines. If a heat shield was included in the kit, install it. If there is no heat shield, but one is required, call Air Lift customer service at (800) 248-0892.
- ❑ **Fastener test** — After 500 miles (800km), recheck all bolts for proper torque.
- ❑ **Road test** — The vehicle should be road tested after the preceding tests. Inflate the air springs to recommended driving pressures. Drive the vehicle 10 miles (16km) and recheck for clearance, loose fasteners and air leaks.
- ❑ **Operating instructions** — If professionally installed, the installer should review the operating instructions with the owner. Be sure to provide the owner with all of the paperwork that came with the kit.

MAINTENANCE AND USE GUIDELINES

1. Check air pressure weekly.
2. Always maintain normal ride height. Never inflate beyond 100 PSI (7BAR).
3. If the system develops an air leak, use a soapy water solution to check all air line connections and the inflation valve core before deflating and removing the air spring.
4. Upon successful completion of the installation, follow these pressure requirements for the air springs.

NOTE

During the research and development of this application, we found that in an unloaded condition, running more than the 5 PSI minimum slightly improved the ride quality of the vehicle.



**Minimum Recommended
Air Pressure**



Maximum Air Pressure



FOR SAFETY AND TO PREVENT POSSIBLE DAMAGE TO THE VEHICLE, DO NOT EXCEED MAXIMUM GROSS VEHICLE WEIGHT RATING (GVWR) OR PAYLOAD RATING, AS INDICATED BY THE VEHICLE MANUFACTURER.

ALTHOUGH THE AIR SPRINGS ARE RATED AT A MAXIMUM INFLATION PRESSURE OF 100 PSI (7BAR), THE AIR PRESSURE ACTUALLY NEEDED IS DEPENDENT ON LOAD AND GROSS VEHICLE WEIGHT RATING.

Limited Warranty and Return Policy

Air Lift Company provides a Limited Lifetime Warranty* to the original purchaser of its load support products, from the date of original purchase, that the products will be free from defects in workmanship and materials when used on cars and trucks as specified by Air Lift Company and under normal operating conditions, subject to the requirements and exclusions set forth in the full Limited Warranty and Return Policy.

*Full Limited Warranty and Return Policy are available at www.airliftcompany.com/warranty and are subject to change.

WARRANTY REGISTRATION & CLAIMS

- To register your warranty, please visit <https://www.airliftcompany.com/support/warranty/register/>
- To submit a warranty claim, please visit <https://www.airliftcompany.com/support/warranty/submit-claim/>



Thank you for purchasing Air Lift Products — the Authorized Installer's choice!

Need Help?

Contact Air Lift Company Customer Service at (800) 248-0892
or email service@airliftcompany.com.

For calls outside the U.S. or Canada: +1 (517) 322-2144.



Air Lift Company • 2727 Snow Road • Lansing, MI 48917 or P.O. Box 80167 • Lansing, MI 48908-0167

Air Lift Company reserves the right to make changes and improvements to its products and publications at any time.
For the latest version of this manual, contact Air Lift Company at (800) 248-0892 or visit airliftcompany.com.