

# LoadLifter 5000™ SERIES + Air Lift® ProSeries



## Installation Guide



*Toyota Tundra*



**Watch the video**

Info on Table of Contents page

# Kits 57383 | 88383 | 77383

For maximum effectiveness and safety, please read these instructions completely before proceeding with installation.

Failure to read these instructions can result in an incorrect installation.

# **Protect your Air Lift Purchase by Completing your Warranty Registration**

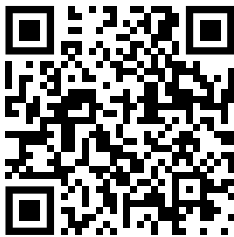

Thank you for purchasing an Air Lift load support product!

Take a photo of your sales receipt and then scan the QR code to complete your online warranty registration.

# TABLE OF CONTENTS

## **2 System Overview**

---

## **3 Hardware and Tools**

---

## **4 Introduction**

Notation Explanation  
Identifying the Differences Between Kits

---

## **5 Installing the System**

Prepare the Vehicle  
Attach the Upper Bracket to the Frame  
Assemble the Air Spring Assemblies  
Install the Air Spring Assemblies

---

## **12 Installing the Air Lines**

Installing Nylon Air Lines  
Installing the Heat Shield

---

## **13 Finished Installation**

---

## **14 Before Operating**

Installation Checklist  
Maintenance and Use Guidelines

---

## **16 Limited Warranty and Return Policy**

# Video-enhanced installation guides

Visit [airliftcompany.com/workshop/category/install-videos](http://airliftcompany.com/workshop/category/install-videos) to access our installation video archive\*.

# System Overview

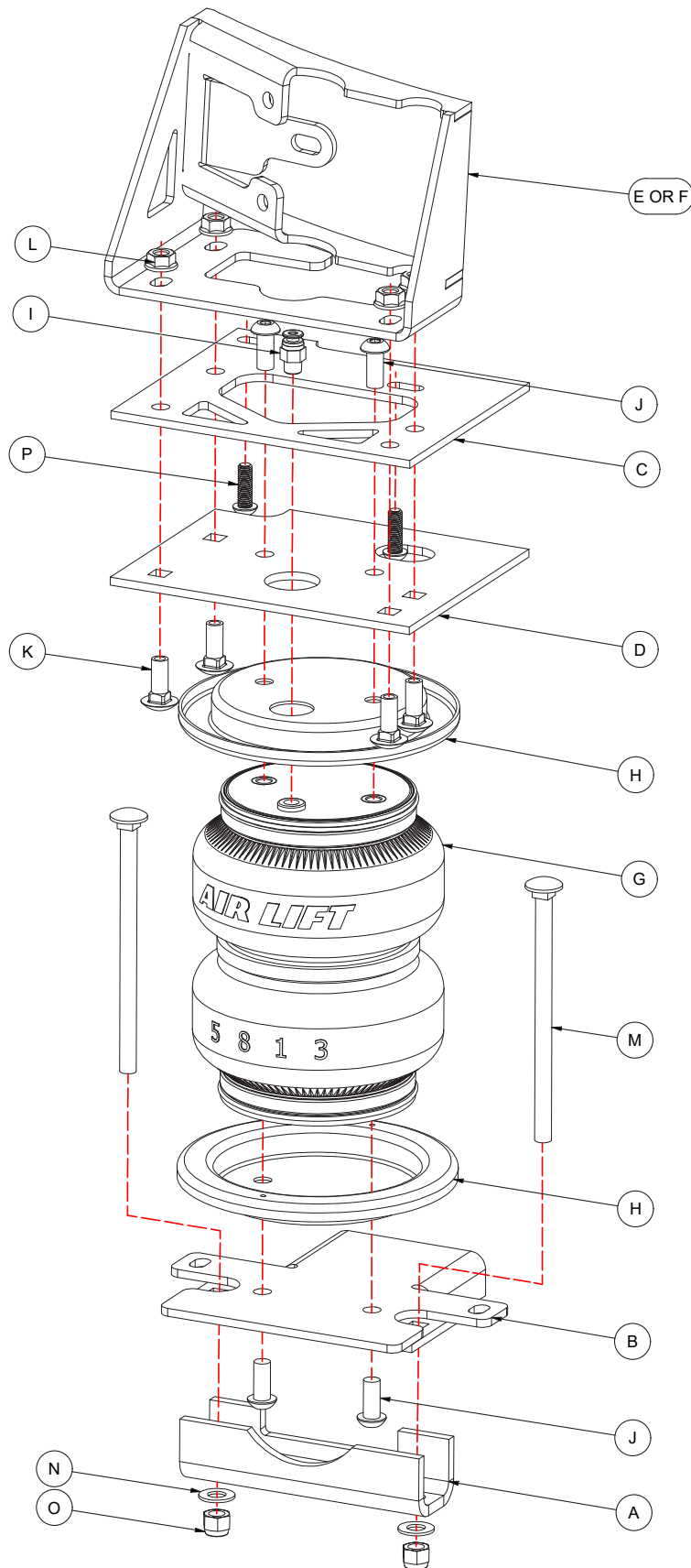

Fig. 1

# Hardware and Tools

## Common Parts Included in All 3 Kits

Item	Part #	Description.....	Qty
A	01535	Clamp bar.....	2
B	03978	Lower bracket.....	2
C	07927	Upper frame bracket.....	2
D	07938	Upper spring bracket.....	2
E	07941	Left hand upper brace.....	1
F	07942	Right hand upper brace.....	1
I	21839	1/4" Air fitting.....	2
J	17527	3/8"-24 x 3/4" Button head screw.....	8
K	17134	3/8"-16 x 1" Carriage bolt.....	8
L	18422	3/8"-16 Serrated flange nut.....	8
M	17133	3/8"-16 x 6" Carriage bolt.....	4
N	18444	3/8" Flat washer.....	4
O	18435	3/8"-16 Nylon lock nut.....	4
P	17937	M8 x 25mm Button head screw.....	4
Q*	18522	M8 x 1.25 Nylon lock nut.....	3
R*	18501	M8 Flat washer.....	3
S*	17444	M8 x 20mm Hex head flange bolt.....	2
AA*	20086	Air line assembly.....	1
BB*	10466	Zip ties.....	6
CC*	21230	Valve cap.....	2
DD*	18411	Star washer.....	2
EE*	21234	Rubber washer.....	2
FF*	18501	M8 Flat washer.....	2
GG*	21233	5/16" Hex nut.....	4

\* These parts are not shown in the System Overview (Fig.1).

## TOOLS NEEDED

Description.....	Qty
Standard and metric open-end or box wrenches.....	Set
9/16 ratchet wrench.....	1
Ratchet.....	1
Standard and metric regular and deep-well sockets.....	Set
Torque wrench.....	1
5mm Hex key.....	1
Hose cutter, razor blade, or sharp knife.....	1
Hoist or floor jack.....	1
Safety glasses.....	1
Safety stands.....	2
Air compressor or compressed air source.....	1
Spray bottle with dish soap/water solution.....	1

The photos in this manual show the LoadLifter 5000 kit.

## Unique Parts in Each Kit

### LoadLifter 5000™ KIT 57383

Item	Part #	Description.....	Qty
G	58437	Air spring.....	2
H	11951	Zinc roll plate.....	4

### LoadLifter 5000™ ULTIMATE KIT 88383

Item	Part #	Description.....	Qty
G	58496	Air spring.....	2
H	11967	Black anodized roll plate.....	4

### Air Lift® ProSeries KIT 77383

Item	Part #	Description.....	Qty
G	58437	Air spring.....	2
H	11951	Zinc roll plate.....	4



Missing or damaged parts? Call Air Lift customer service at (800) 248-0892 for a replacement part.

# Introduction

The purpose of this publication is to assist with the installation and maintenance of the LoadLifter 5000 series and Air Lift ProSeries air spring kits. All LoadLifter 5000 series and Air Lift ProSeries kits utilize sturdy, reinforced, commercial-grade single or double, depending on the kit, convolute bellows.

The air springs are manufactured like a tire with layers of rubber and cords that control growth. LoadLifter 5000 series and Air Lift ProSeries kits provide up to 5,000 pounds (2,268kg) of load-leveling support with air adjustability from 5-100 PSI (.34-7BAR).

It is important to read and understand the entire installation guide before beginning installation or performing any maintenance, service or repair.

## NOTATION EXPLANATION

Hazard notations appear in various locations in this publication. Information highlighted by one of these notations must be observed to help minimize risk of personal injury or possible improper installation, which may render the vehicle unsafe. Notes are used to help emphasize areas of procedural importance and provide helpful suggestions. The following definitions explain the use of these notations as they appear throughout this installation guide.



INDICATES IMMEDIATE HAZARDS WHICH WILL RESULT IN SEVERE PERSONAL INJURY OR DEATH.



INDICATES HAZARDS OR UNSAFE PRACTICES WHICH COULD RESULT IN SEVERE PERSONAL INJURY OR DEATH.



INDICATES HAZARDS OR UNSAFE PRACTICES WHICH COULD RESULT IN DAMAGE TO THE MACHINE OR MINOR PERSONAL INJURY.



Used to help emphasize areas of procedural importance and provide helpful suggestions.

## IDENTIFYING THE DIFFERENCES BETWEEN KITS

Should you need to contact Air Lift customer service, you will need to know which kit you are inquiring about: standard LoadLifter 5000, LoadLifter 5000 Ultimate or Air Lift® ProSeries (77-Series). The kits are easily identifiable by looking at the end caps on the air spring and the roll plates.

- Standard **LoadLifter 5000**  
Zytel® plastic end cap and Zinc-plated steel roll plates.
- LoadLifter 5000 Ultimate**  
Zytel® plastic end cap and Black powder-coated roll plates.
- Standard **Air Lift® ProSeries (77-Series)**  
Zytel® plastic end cap and Zinc-plated steel roll plates.



LoadLifter 5000  
Zytel® plastic end cap



LoadLifter 5000  
silver zinc-plated steel roll plate



LoadLifter 5000 Ultimate  
Zytel® plastic end cap



LoadLifter 5000 Ultimate  
black powder-coated roll plate



Air Lift® ProSeries (77-Series)  
Zytel® plastic end cap



Air Lift® ProSeries (77-Series)  
silver zinc-plated steel roll plate

# Installing the System

## PREPARE THE VEHICLE

1. Lift the vehicle and support the frame with safety stands (Fig. 2). Drop the axle down low enough to later set the air springs into position between the frame and axle.

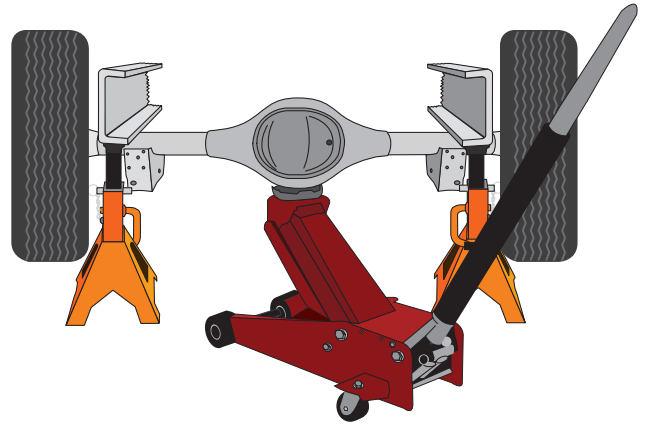

Fig. 2

2. Use a 12mm ratchet or wrench to remove the factory jounce bumpers from both sides of the vehicle. They are held on by three bolts each (Fig. 3). One on the side of the frame and two on the bottom of the frame. Your frame should look like Figure 4 when this step is completed.

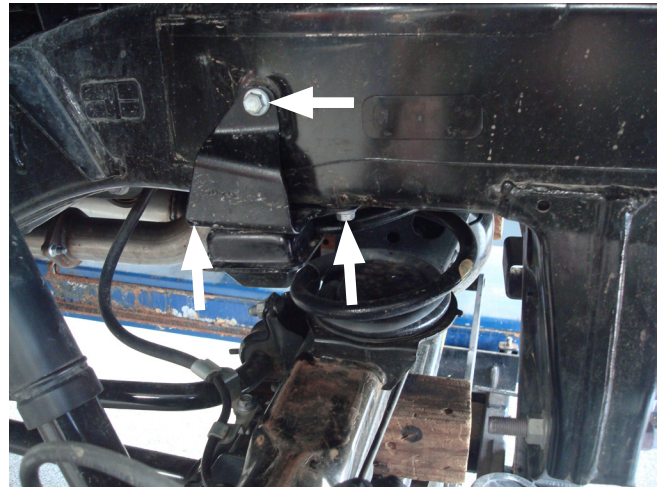

Fig. 3



Fig. 4

- Use a small prybar or flathead screwdriver to pry off the two plastic covers, removing one from each side (Fig. 5). On the passenger's (right) side, you will also have to remove a module. After removing these two bolts (Fig. 6) with a 12mm socket or wrench, tuck the module out of the way for now.

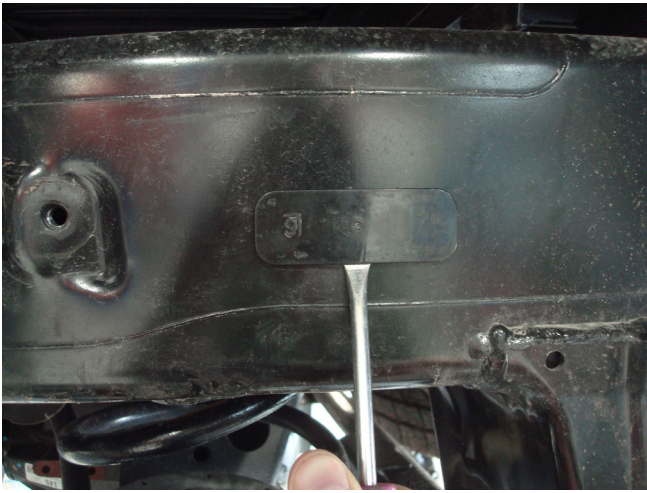

Fig. 5

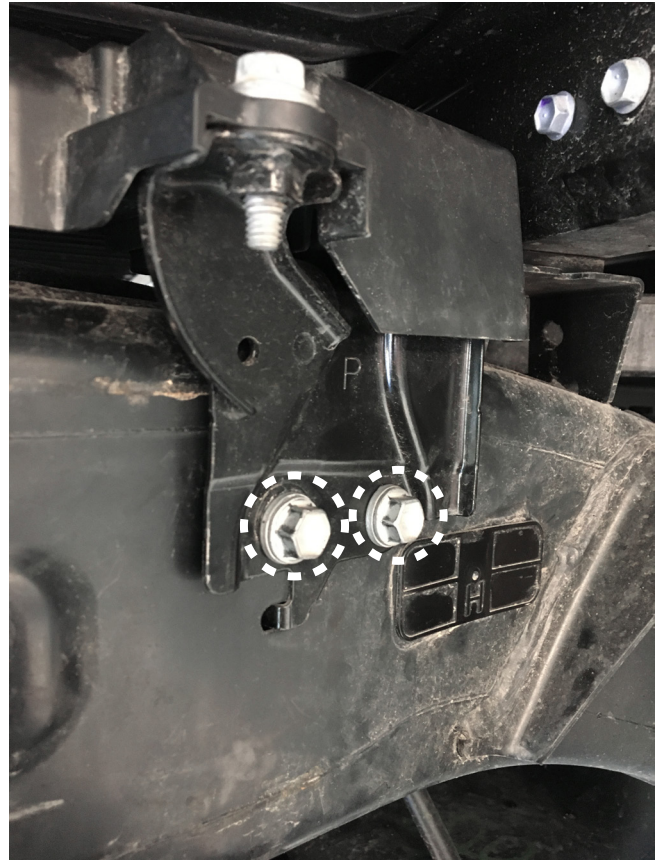

Fig. 6

## ATTACH THE UPPER BRACKET TO THE FRAME

- Attach the upper frame brackets (C) to the frame, one on each side, using the four M8 button head cap screws (P). Using a 5mm hex tool, thread the screws through the slotted holes in the bracket (Fig. 7) and then into the frame holes (Fig. 8). These are the same holes used for the jounce bumper that was just removed. Do not tighten the hardware down, make sure the brackets can slide front to back slightly for the next step. The wider-spaced holes need to face the front of the vehicle.

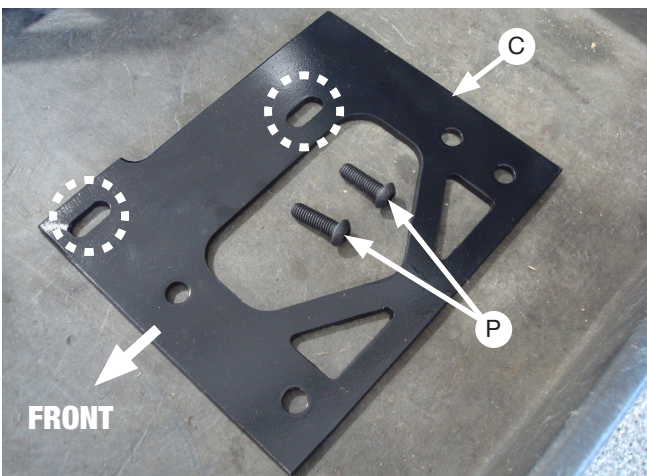

Fig. 7



Fig. 8

- The M8 screws from the previous step are almost ready to be tightened down. First, the upper brace is needed to make sure the frame plate is aligned. Place the upper brace (E or F, depending on the side) on top of the frame plate (Fig. 9). Move them around slightly until you get the frame hole aligned (circled in gray) and the brace holes aligned with the upper frame holes (C) (circled in white). Once they are aligned, tighten the two M8 screws (P) down to 18 lb.-ft. (24Nm) with a 5mm hex tool. Remove the upper brace (E or F).

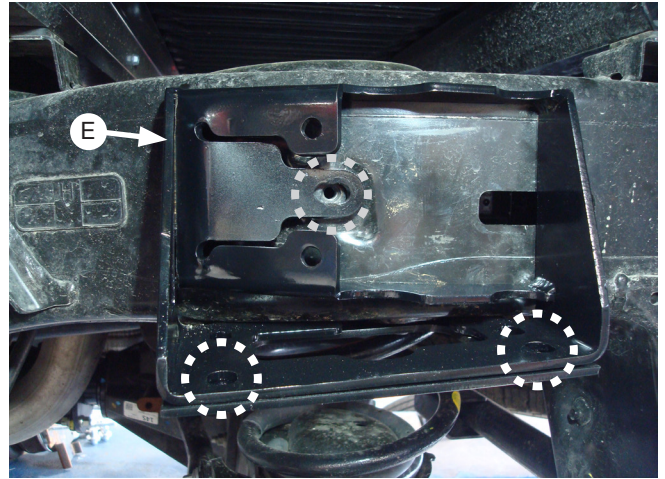

Fig. 9

- Remove the bolts that hold the emergency brake cables to the axle. There is one on each side (Fig. 10).



Fig. 10

## ASSEMBLE THE AIR SPRING ASSEMBLIES

- Install the air fitting (I) into the air spring (G) (Fig. 11). Thread on finger-tight, then finish tightening the fitting another 1 1/2 turns with a 1/2" wrench.



Fig. 11

- Place a roll plate (H) on top of the air spring (Fig. 12). Place two 1" carriage bolts (K) into the upper spring plate (D) (Fig. 13), then screw the plate to the air spring with two button head screws (J). Torque to no more than 20 lb.-ft. (27Nm).

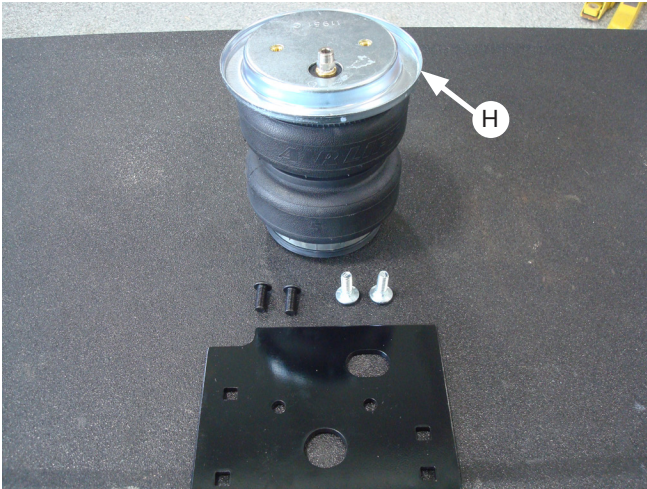

Fig. 12

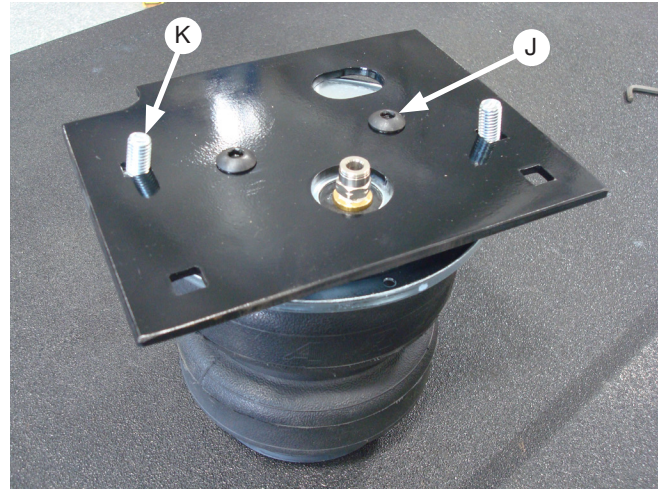

Fig. 13

- The other side is the same but mirrored (Fig. 16)
- Install the lower bracket onto the air spring using a roll plate (H), lower bracket (B), two long carriage bolts (M) and button head screws (J) (Fig. 14). Flip the air spring assembly over and place the roll plate on the air spring, then put the carriage bolts through the lower bracket as shown in Figure 15.



Fig. 14

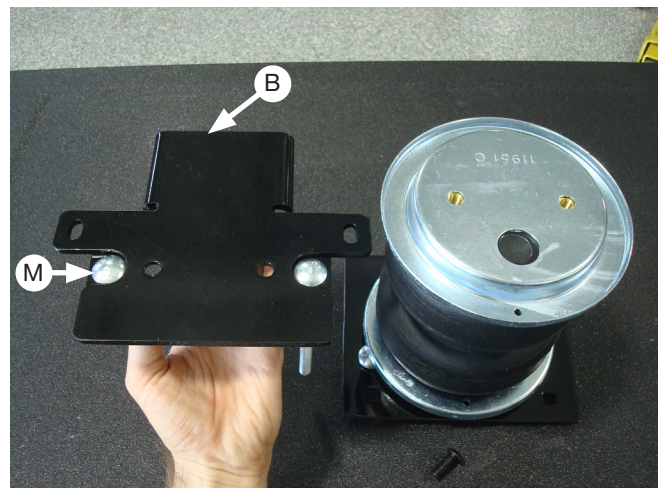

Fig. 15

- Place the lower bracket assembly onto the air spring assembly and secure it with two 3/8"-24 button head screws (J). Torque them to no more than 20 lb.-ft. (27Nm)
- Repeat these steps for the other side. The completed assemblies are shown in Figure 16.



For proper installation of the assemblies make sure the tabs (circled in white) are on the opposite side of the air port or on the same side as the upper bracket notches (circled in gray) (Fig. 16).

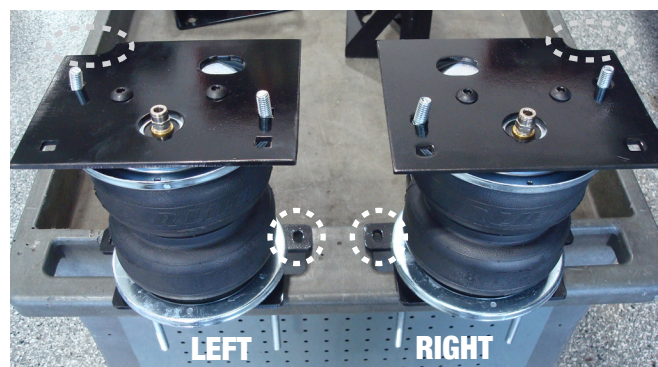

Fig. 16

## INSTALL THE AIR SPRING ASSEMBLIES

1. Installing the assemblies is made easier by supporting the vehicle frame and dropping the axle down slightly (Fig. 2). The lower bracket will sit directly on the axle.
2. Once each assembly is in place, thread two serrated nuts (L) onto the two short carriage bolts (K) from step 2 of the *Assembling the Air Spring Assemblies* section, but leave them loose at this time (Fig. 17). Install an M8 flanged bolt (S) through the upper brace into the frame (circled in gray) (Fig. 17) and torque to 18 lb.-ft. (24Nm). Torque the two serrated nuts (circled in white) to 16 lb.-ft. (22Nm) (Fig. 17).
3. Install the remaining short carriage bolts (K) and serrated flange nuts (L) (Fig. 19). Torque them to 16 lb.-ft. (22Nm) and the assembly should appear as shown in Figure 19.
4. Using one of the previously removed module bolts from step 3 (Fig. 6) of the *Prepare the Vehicle* section with an M8 washer (R) and M8 lock nut (Q), attach the module to the upper brace (Fig. 18). Torque to 18 lb.-ft. (24Nm).

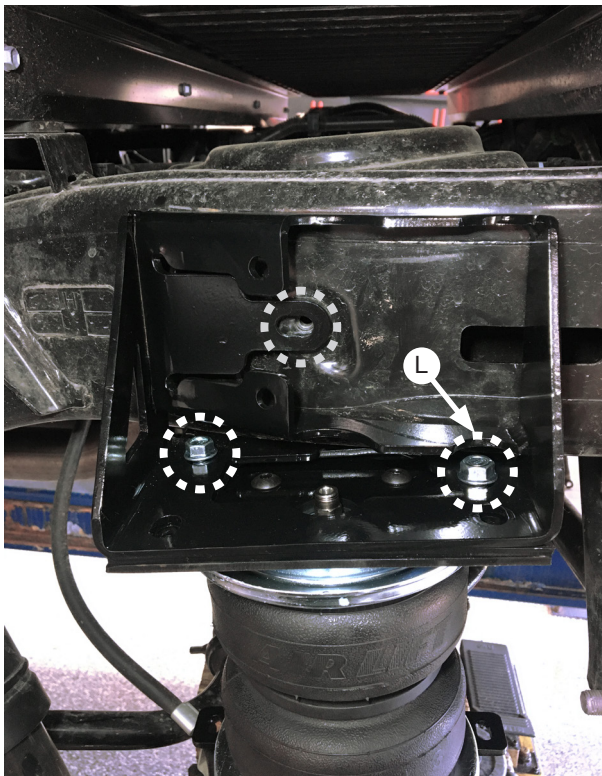

Fig. 17

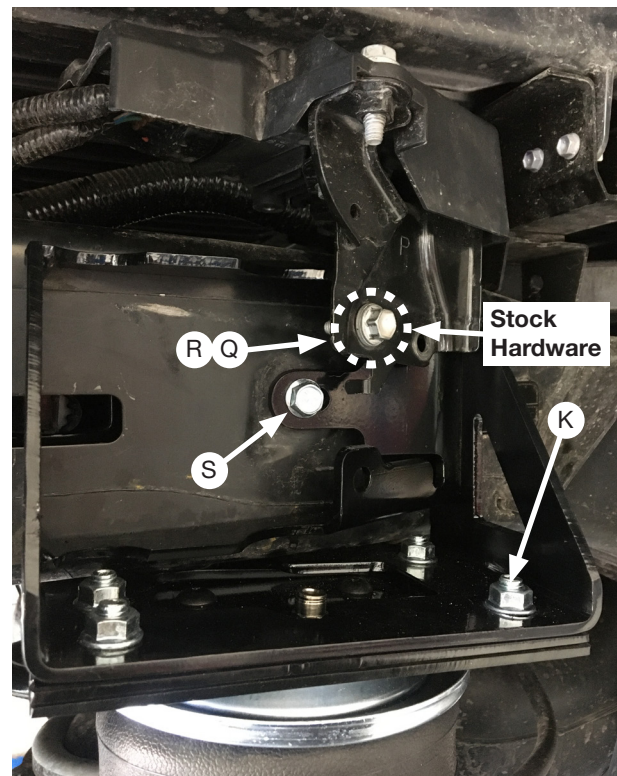

Fig. 18



Fig. 19

- Complete the lower mounting. Slip the lower clamp bar (A) over the long carriage bolts (M). Install a flat washer (N) and nylon lock nut (O) onto each of the lower carriage bolts (Fig. 20). Torque each nut to 10 lb.-ft. (14Nm) making sure to tighten the nuts down evenly so the clamp bar is level. Be sure to leave adequate clearance between the carriage bolts and the brake lines (Fig. 21).

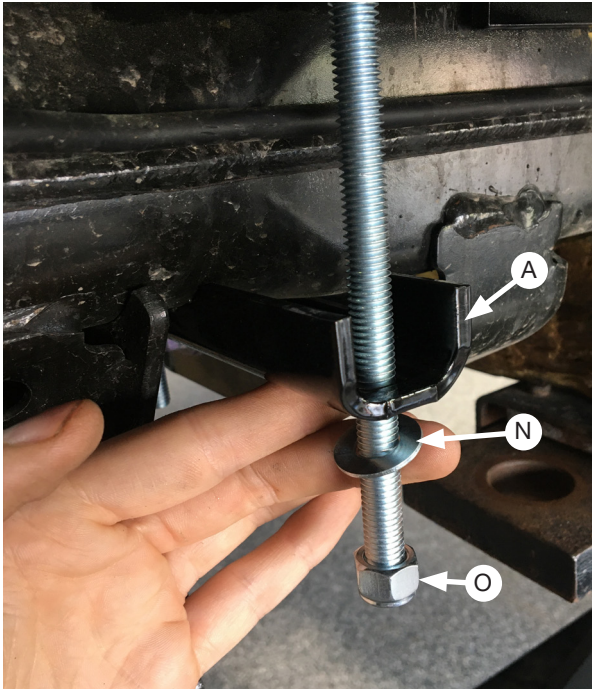

Fig. 20



Fig. 21

- Remove the OEM brake line clips on the axle and flip them around (Figs. 22 & 23) or push the line towards the axle to bend it out of the way.



THE BRAKE LINES SHOULD NOT TOUCH THE CARRIAGE BOLTS. PUSH OR BEND THE BRAKE LINES AS NEEDED TO KEEP THEM OUT OF THE WAY OF THE CARRIAGE BOLTS.



Fig. 22



Fig. 23

7. Use the OEM bolt that was removed from the brake cable bracket in step 3 of *Attach the Upper Bracket to the Frame* section along with an M8 washer (R), M8 lock nut (Q) (Fig. 24) and attach the brake cable bracket to the tab on the lower bracket (Fig. 25)



Fig. 24

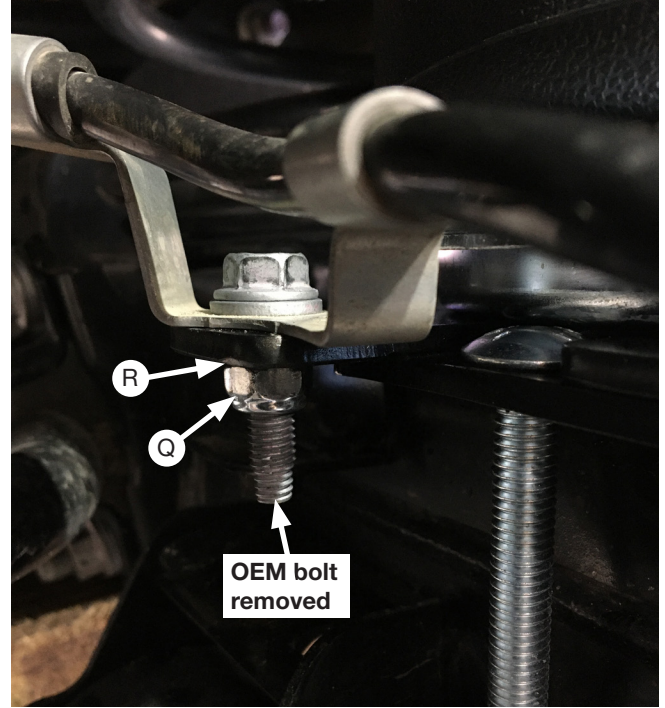
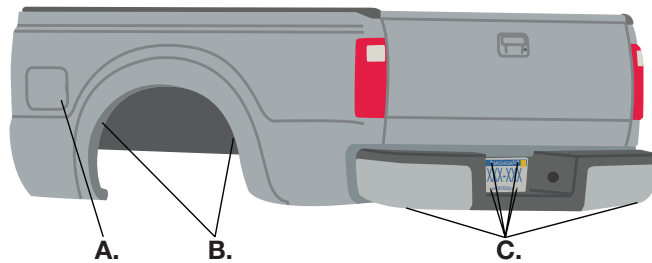

Fig. 25

# Installing the Air Lines

Begin by choosing locations for the Schrader valves and drill a 5/16" (8mm) hole, if necessary.



- A. Inside fuel tank filler door    B. Inside rear wheel wells    C. License plate or rear bumper area



KEEP AT LEAST 6" (150MM) OF CLEARANCE BETWEEN ALL AIR LINES AND THE EXHAUST SYSTEM. AVOID SHARP BENDS AND EDGES.

## INSTALLING NYLON AIR LINES

The nylon air lines are routed from the air springs to Schrader valves.

1. For nylon air line, it is recommended that the air line be routed along the top of the frame, forward of the axle, then down to the fitting. After cutting the air line to length, install the air line thermal sleeve over the air line on the passenger's (right) side before inserting into the fitting. Secure the air lines to the upper coil spring mount with zip ties (BB) supplied.
2. Make clean, square cuts with a razor blade or hose cutter when cutting the air line (AA). Do not use scissors or wire cutters.

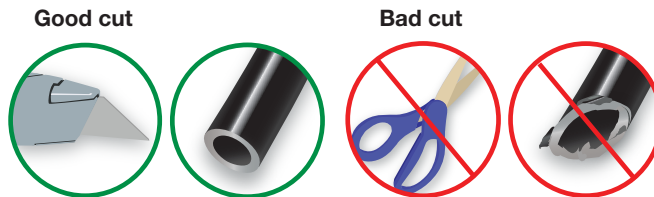

3. Use zip ties (BB) to secure the air line to fixed points along the chassis. Do not pinch or kink the air line. The minimum bend radius for the air line is 1" (25mm). Leave at least 2" (50mm) of slack in the air line to allow for any movement that might pull on the air line.
4. Install the Schrader valve in the chosen location.

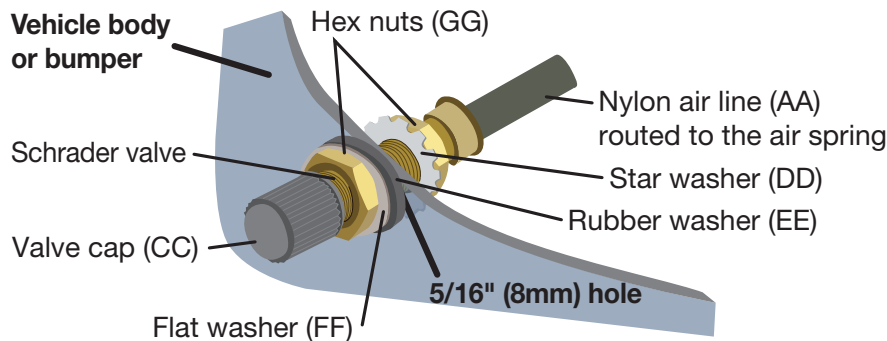

## Finished Installation

The images show the finished installation of both sides.

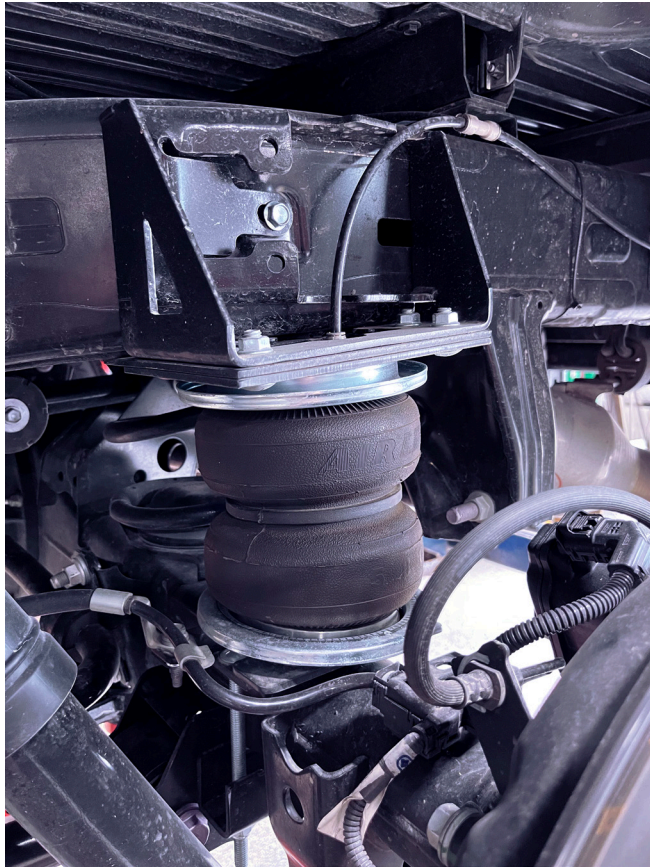

Outside, forward of axle view of driver's (left) side installation.



Outside, forward of axle view of passenger's (right) side installation.

# Congratulations!

You are now the proud owner of an Air Lift air suspension system. Enjoy!

# Before Operating

## INSTALLATION CHECKLIST

- Clearance test** — Inflate the air springs to 40-60 PSI (2.8-4.1BAR) and make sure there is at least 1/2" (13mm) clearance from anything that might rub against each sleeve. Be sure to check the tire, brakes, frame, shock absorbers and brake cables.
- Leak test before road test** — Inflate the air springs to 40-60 PSI (2.8-4.1BAR) and check all connections for leaks. All leaks must be eliminated before the vehicle is road-tested.
- Heat test** — Be sure there is sufficient clearance from heat sources, at least 6" (152mm) for air springs and air lines. If a heat shield was included in the kit, install it. If there is no heat shield, but one is required, call Air Lift customer service at (800) 248-0892.
- Fastener test** — After 500 miles (800km), recheck all bolts for proper torque.
- Road test** — The vehicle should be road-tested after the initial tests. Inflate the air springs to recommended driving pressures. Drive the vehicle 10 miles (16km) and recheck for clearance, loose fasteners and air leaks.
- Operating instructions** — If professionally installed, the installer should review the operating instructions with the owner. Be sure to provide the owner with all of the paperwork that came with the kit.

## MAINTENANCE AND USE GUIDELINES

1. Check air pressure weekly.
2. Always maintain normal ride height. Never inflate beyond 100 PSI (7BAR).
3. If the system develops an air leak, use a soapy water solution to check all air line connections and the inflation valve core before deflating and removing the air spring.
4. Upon successful completion of the installation, follow these pressure requirements for the air springs.



**Minimum Recommended Air Pressure**



**Maximum Air Pressure**



FOR SAFETY AND TO PREVENT POSSIBLE DAMAGE TO THE VEHICLE, DO NOT EXCEED MAXIMUM GROSS VEHICLE WEIGHT RATING (GVWR) OR PAYLOAD RATING, AS INDICATED BY THE VEHICLE MANUFACTURER.

ALTHOUGH THE AIR SPRINGS ARE RATED AT A MAXIMUM INFLATION PRESSURE OF 100 PSI (7BAR), THE AIR PRESSURE ACTUALLY NEEDED IS DEPENDENT ON LOAD AND GROSS VEHICLE WEIGHT RATING.

# Notes



## Limited Warranty and Return Policy

Air Lift Company provides a Limited Lifetime Warranty\* to the original purchaser of its load support products, from the date of original purchase, that the products will be free from defects in workmanship and materials when used on cars and trucks as specified by Air Lift Company and under normal operating conditions, subject to the requirements and exclusions set forth in the full Limited Warranty and Return Policy.

\*Full Limited Warranty and Return Policy are available at [www.airliftcompany.com/warranty](http://www.airliftcompany.com/warranty) and are subject to change.

### WARRANTY REGISTRATION & CLAIMS

- To register your warranty, please visit <https://www.airliftcompany.com/support/warranty/register/>
- To submit a warranty claim, please visit <https://www.airliftcompany.com/support/warranty/submit-claim/>





*Thank you for purchasing Air Lift Products!*

## Need Help?

Contact Air Lift Company Customer Service at (800) 248-0892  
or email [service@airliftcompany.com](mailto:service@airliftcompany.com).

For calls outside the U.S. or Canada, dial +1 (517) 322-2144.



MADE IN USA  
WITH GLOBAL  
COMPONENTS

Air Lift Company • 2727 Snow Road • Lansing, MI 48917 or P.O. Box 80167 • Lansing, MI 48908-0167

Air Lift Company reserves the right to make changes and improvements to its products and publications at any time.  
For the latest version of this manual, contact Air Lift Company at (800) 248-0892 or visit [airliftcompany.com](http://airliftcompany.com).