

LoadLifter 5000™ SERIES + Air Lift® ProSeries



Installation Guide



** LoadLifter 5000 Ultimate kit shown here*

Ford F-250/F-350/F-450



Watch the video
Info on Table of Contents page

Kits 57396 | 88396 | 93396 | 77396

For maximum effectiveness and safety, please read these instructions completely before proceeding with installation.

Failure to read these instructions can result in an incorrect installation.

Protect your Air Lift Purchase by Completing your Warranty Registration



Thank you for purchasing an Air Lift load support product!

Take a photo of your sales receipt and then scan the QR code to complete your online warranty registration.

TABLE OF CONTENTS

2 System Overview

3 Hardware and Tools

4 Introduction

Notation Explanation
Identifying the Differences Between Kits

5 Install the System

Prepare the Vehicle
Install the Braces
Retaining Clip L-Bracket Installation on Brace
Driver's Side Brace Installation
Passenger's Side Brace Installation
Air Spring and Bracket Assembly
Attach the Assemblies to the Frame
Attach the Lower Bracket to the Axle

22 Install the Air Lines

Install the Heat Shield

24 Finished Installation

24 Before Operating

Installation Checklist
Maintenance and Use Guidelines

25 Limited Warranty and Return Policy

Video-enhanced installation guides

Visit airliftcompany.com/workshop/category/install-videos to access our installation video archive*.

System Overview

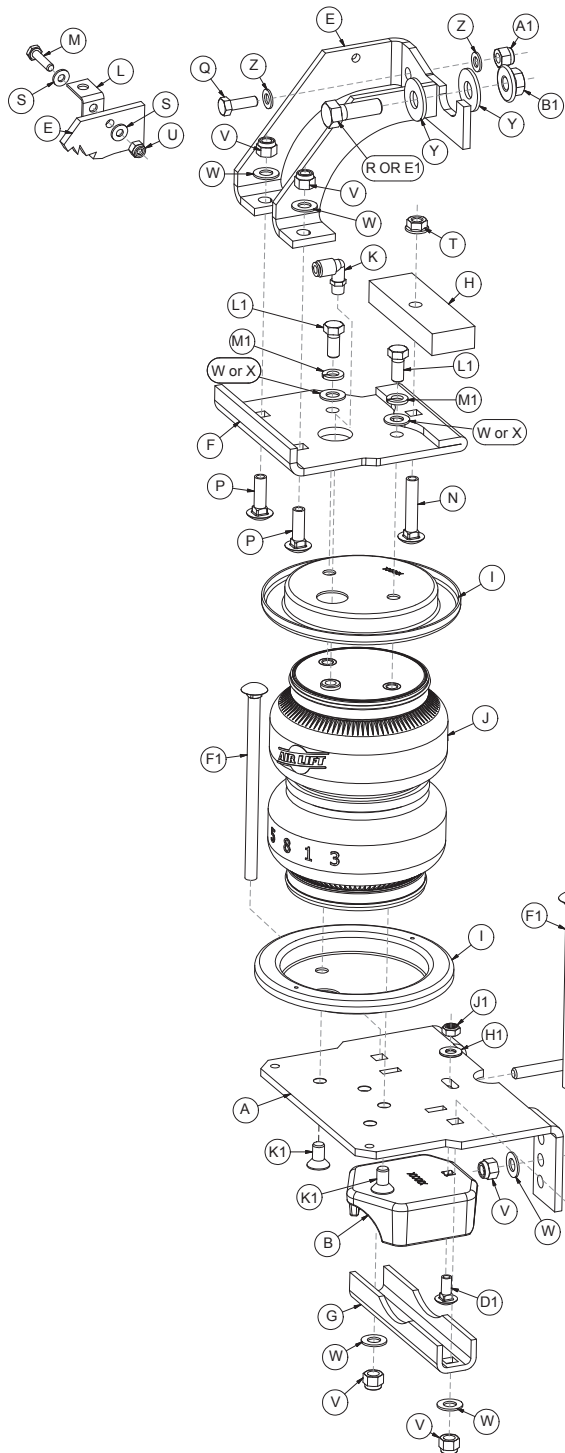

Driver's Side

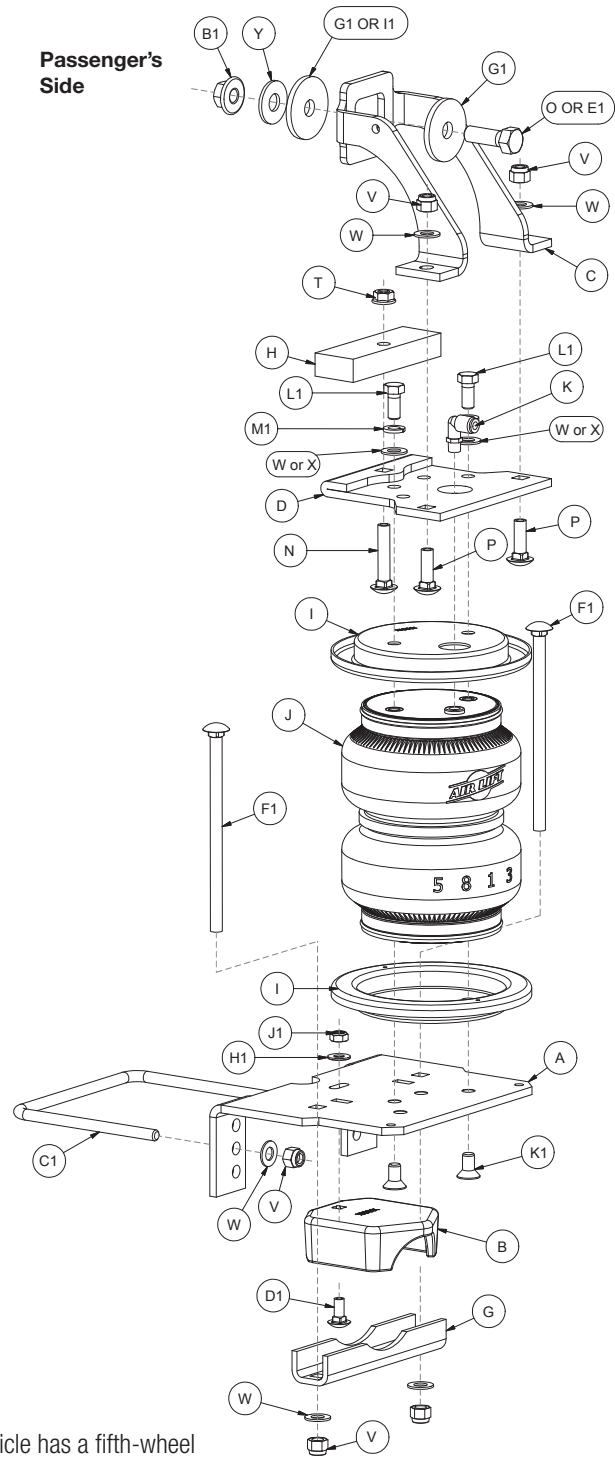

Passenger's Side

* NOTE: If the vehicle has a fifth-wheel hitch installed that has side plates along the frame, use the existing hardware that was removed. If not, use the 1/2" hardware supplied and recommended in this kit and in the directions in this manual.

Fig. 1

Hardware and Tools

Common Parts Included in All 4 Kits

Item	Part#	Description	Qty
A	03997	Lower bracket main plate	2
B	03998	Lower bracket cup	2
C	07996	Passenger's (right) side upper brace	2
D	07997	Passenger's (right) side upper bracket	1
E	07994	Driver's (left) side upper brace	1
F	07995	Driver's (left) side upper bracket	1
G	01531	Clamp bar	2
H	13966	Spacer	2
K	21837	Push-to-connect (PTC) fitting	2
L	10886	"L" bracket	1
M	17135	1/4"-20 x 1" Hex-cap screw	1
N	17140	3/8"-16 x 2" Carriage bolt	2
O	17161	1/2"-13 x 1 1/2" Hex-cap screw	1
P	17361	3/8"-16 x 1 1/4" Carriage bolt	4
Q	17177	M8-1.25 x 25 Hex-cap screw	1
R	17412	1/2"-13 x 1 1/4" Hex-cap screw	1
S	18419	#12 Flat washer	2
T	18422	3/8"-16 Serrated flange lock nut	2
U	18425	1/4"-20 Nylon lock nut	1
V	18435	3/8"-16 Nylon lock nut	12
W	18444	3/8" Flat Washer	12
Y	18485	1/2" Flat washer	3
Z	18501	M8 Stainless steel flat washer	4
A1	18522	M8-1.25 Nylon lock nut	1
B1	18505	1/2"-13 Serrated flange lock nut	2
C1	11717	U-bolt	2
D1	17500	5/16"-18 x 3/4" Carriage bolt	2
E1	17271	1/2"-13 x 3" Hex-cap screw	2
F1	17387	3/8"-16 x 10" Carriage bolt	4
G1	18207	1/2" Thick flat washer	2
H1	18433	5/16" Flat washer	2
I1	18556	3/4" Flat washer	1
J1	18613	5/16"-18 Nylon lock nut	2
AA*	20086	Air line assembly	1
BB*	10466	Zip ties	6
CC*	21230	Valve cap	2
DD*	18411	Star washer	2
EE*	21234	Rubber washer	2
FF*	18501	M8 Flat washer	2
GG*	21233	5/16" Hex nut	4
HH*	34924	Heat shield kit	1

* Not pictured in the System Overview (Fig. 1)

TOOLS LIST

Description	Qty
Standard and metric open-end or box wrenches	Set
Ratchet with standard and metric sockets	Set
5/16" drill bit (very sharp)	1
Heavy-duty drill	1
Torque wrench	1
Wire brush	1
Standard and metric hex-key wrenches	Set

Unique Parts in Each Kit

LoadLifter 5000™ KIT 57396

Item	Part #	Description	Qty
I	11951	Roll plate (silver zinc-plated)	4
J	58437	Air spring	2
W	18444	3/8" Flat washer	4
K1	17215	3/8"-24 x 3/4" Flat-head screw	4
L1	17203	3/8"-24 x 7/8" Hex cap screw	4
M1	18427	3/8" Lock washer	4

LoadLifter 5000™ ULTIMATE KIT 88396

Item	Part #	Description	Qty
I	11967	Roll plate (black powder-coated)	4
J	58496	Air spring with internal jounce bumper	2
W	18444	3/8" Flat washer	4
K1	17215	3/8"-24 x 3/4" Flat-head screw	4
L1	17203	3/8"-24 x 7/8" Hex cap screw	4
M1	18427	3/8" Lock washer	4

Air Lift® ProSeries KIT 93396

Item	Part#	Description	Qty
I	11951	Roll plate (silver zinc-plated)	4
J	58937	Air spring	2
X	18507	3/8" Stainless flat washer	4
K1	17363	3/8"-24 x 3/4" Stainless flat-head screw	4
L1	17284	3/8"-24 x 7/8" Stainless hex cap screw	4
M1	18504	3/8" Stainless lock washer	4
II*	21838	Tee fitting	1

Air Lift® ProSeries KIT 77396

Item	Part #	Description	Qty
I	11951	Roll plate (silver zinc-plated)	4
J	58437	Air spring	2
W	18444	3/8" Flat washer	4
K1	17215	3/8"-24 x 3/4" Flat-head screw	4
L1	17203	3/8"-24 x 7/8" Hex cap screw	4
M1	18427	3/8" Lock washer	4

The photos in this manual show the LoadLifter 5000 Ultimate kit.



Missing or damaged parts? Call Air Lift customer service at (800) 248-0892 for a replacement part.

Introduction

The purpose of this publication is to assist with the installation and maintenance of the LoadLifter 5000 series and Air Lift ProSeries air spring kits. All LoadLifter 5000 series and Air Lift ProSeries kits utilize sturdy, reinforced, commercial-grade single or double, depending on the kit, convolute bellows.

The air springs are manufactured like a tire with layers of rubber and cords that control growth. LoadLifter 5000 series and Air Lift ProSeries kits provide up to 5,000 pounds (2,268kg) of load-leveling support with air adjustability from 5-100 PSI (.34-7BAR).

It is important to read and understand the entire installation guide before beginning installation or performing any maintenance, service or repair.

NOTATION EXPLANATION

Hazard notations appear in various locations in this publication. Information highlighted by one of these notations must be observed to help minimize risk of personal injury or possible improper installation, which may render the vehicle unsafe. Notes are used to help emphasize areas of procedural importance and provide helpful suggestions. The following definitions explain the use of these notations as they appear throughout this installation guide.



INDICATES IMMEDIATE HAZARDS WHICH WILL RESULT IN SEVERE PERSONAL INJURY OR DEATH.



INDICATES HAZARDS OR UNSAFE PRACTICES WHICH COULD RESULT IN SEVERE PERSONAL INJURY OR DEATH.



INDICATES HAZARDS OR UNSAFE PRACTICES WHICH COULD RESULT IN DAMAGE TO THE MACHINE OR MINOR PERSONAL INJURY.



Used to help emphasize areas of procedural importance and provide helpful suggestions.

IDENTIFYING THE DIFFERENCES BETWEEN KITS

Should you need to contact Air Lift customer service, you will need to know which kit you are inquiring about: standard LoadLifter 5000, LoadLifter 5000 Ultimate, standard Air Lift® ProSeries (93-Series) or Air Lift® ProSeries (77-Series). The kits are easily identifiable by looking at the end caps on the air spring and the roll plates.

- Standard **LoadLifter 5000**
Zytel® plastic end cap and Zinc-plated steel roll plates.
- LoadLifter 5000 Ultimate**
Zytel® plastic end cap and Black powder-coated roll plates.
- Standard **Air Lift® ProSeries (93-Series)**
Aluminum end cap and Zinc-plated steel roll plates.
- Standard **Air Lift® ProSeries (77-Series)**
Zytel® plastic end cap and Zinc-plated steel roll plates.



LoadLifter 5000
Zytel® plastic end cap



LoadLifter 5000
silver zinc-plated steel roll plate



LoadLifter 5000 Ultimate
Zytel® plastic end cap



LoadLifter 5000 Ultimate
black powder-coated roll plate



Air Lift® ProSeries (93-Series)
Aluminum end cap



Air Lift® ProSeries (93-Series)
silver zinc-plated steel roll plate



Air Lift® ProSeries (77-Series)
Zytel® plastic end cap



Air Lift® ProSeries (77-Series)
silver zinc-plated steel roll plate

Install the System

PREPARE THE VEHICLE

1. Raise the vehicle and support it in a way, using safety stands or equivalent, that the axle can be safely dropped away from the frame. This will need to be done in order for the air spring assembly to be put into position between the axle and frame (Fig. 2).

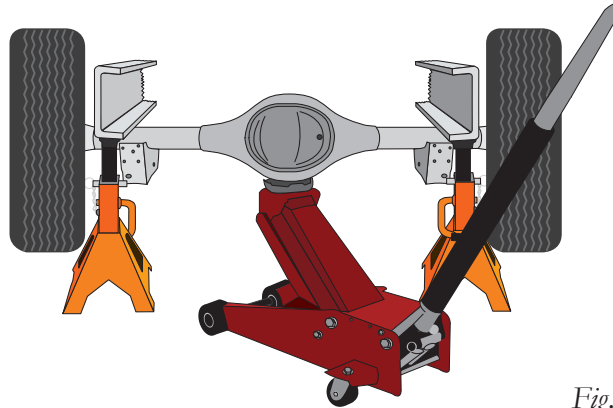

Fig. 2

2. Remove the jounce bumper from under the frame, over the axle (Figs. 3 & 4).

NOTE

Wire brush the stud on the jounce bumper and use penetrating oil to help in removal of the jounce bumper. Usually, the socket size for the nut is a 15mm.

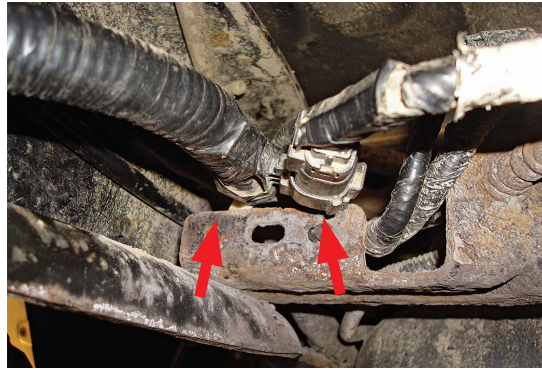

Fig. 3



Fig. 4

3. If necessary, disconnect the wiring harness from the driver's side frame rail to gain clearance for the upper brace (Fig. 5). Also, push out the harness connector that holds the electrical lines going to the gas/urea tank in or out of the tank bracket. This will improve socket/bolt access that will be required for installing and tightening the frame brace (Fig. 6).



Remove the line holders from the gas/urea tank bracket for easier access to the upper brace hardware.

Fig. 5

4. If the truck has a fifth-wheel hitch already installed, **other than the standard factory Reese hitch** purchased with the truck, it will be necessary to remove the hardware that bolts the side bracket (plates) to the outside of the frame above the axle.

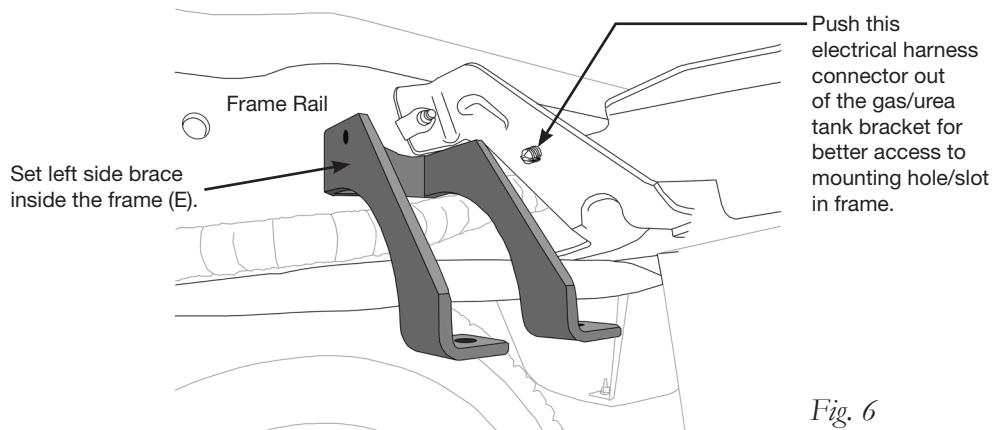

Fig. 6

INSTALL THE BRACES

Gas engine models have emission lines on the inside of the frame. If the truck has emission lines running along the inside of the frame rail (Fig. 7), it will be necessary to relocate those lines as follows:

1. Carefully push the line holder out of the frame above the axle. Try to minimize damage because it will be reused later. It may also be helpful to remove any emissions/fuel line retaining clips forward or rearward of the axle to aid in positioning the lines once the upper brace has been installed (Figs. 7 & 8). The same holds true for the electrical wire loom retaining clips.



If equipped, this emissions/fuel line holder must be pulled away from the frame in order to install the upper frame brace (E).

Fig. 7

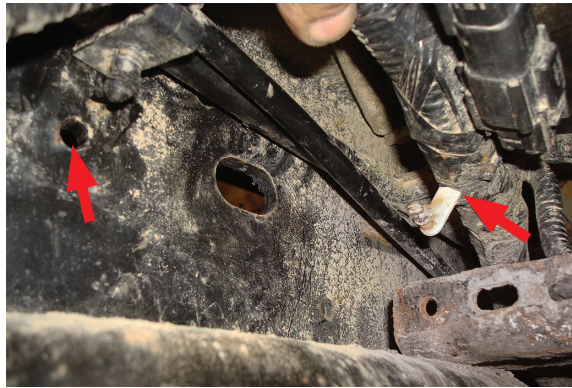

Image shows lines clear on the frame opening it up for the brace installation.

Fig. 8

RETAINING CLIP L-BRACKET INSTALLATION ON BRACE



In order to reattach the previously removed emissions line holder, it will be necessary to attach the provided L-bracket (L) to the back frame brace.

1. Using the supplied 1/4"-20 x 1" hex cap screw (M), #12 flat washers (S), and 1/4"-20 nylon lock nut (Figs. 9 & 10), attach the L-bracket where the emissions line holder or wiring retaining clip (previously detached from frame) is located.

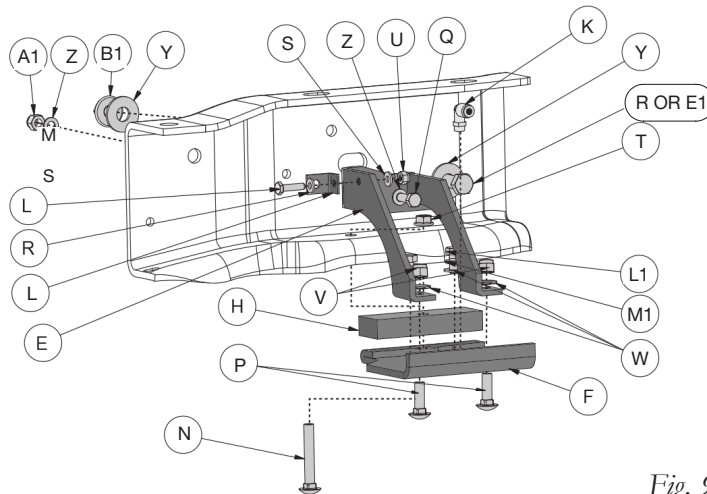

Fig. 9

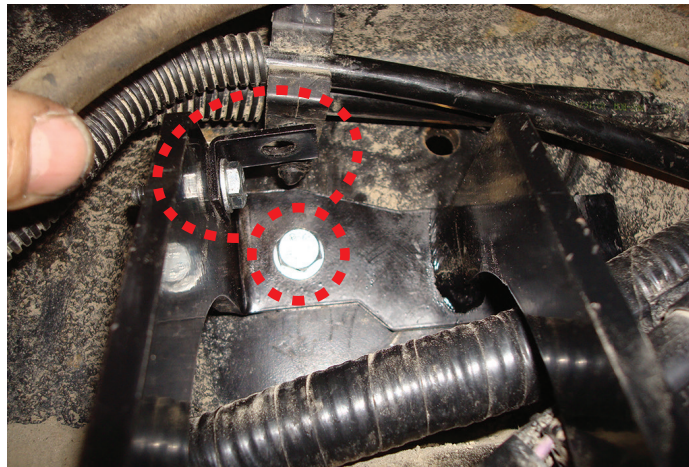
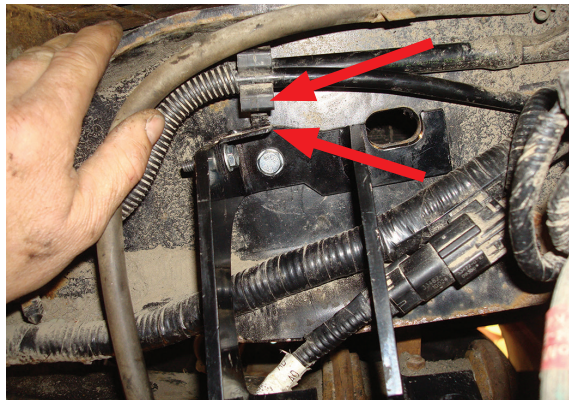

Fig. 10

- Set the driver's side frame brace (E) up into the frame and insert the M8-1.25 x 25mm hex cap screw (Q) with an M8 flat washer (Z) through the brace and into the hole in the side of the frame from which the line holder was removed (Fig. 11). This will hold the line in place. Note what side the line holder is in with respect to the back leg of the brace. Is it forward or behind the back leg of the brace? The L-bracket is to be installed where the line holder lines up with the previously removed line holder. (Figs. 9 & 10).



Brace being temporarily held in place by the M8 bolt and washer. L-bracket is shown in location already. Note: The side the line holder is on depends on the location of the factory retaining clip.

Fig. 11

- Pull the brace back out and attach the L-bracket onto the brace with the hardware noted above, in the proper location previously found (Figs. 12 & 13). Make sure the L-bracket faces up and tighten securely.

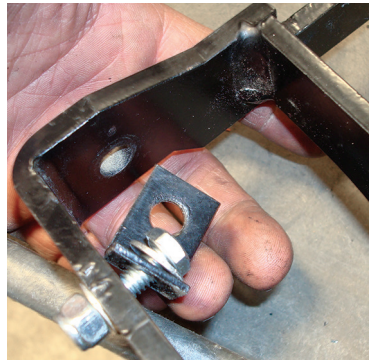

Fig. 12

Attach the L-bracket to the brace in the position previously found using the hardware specified.

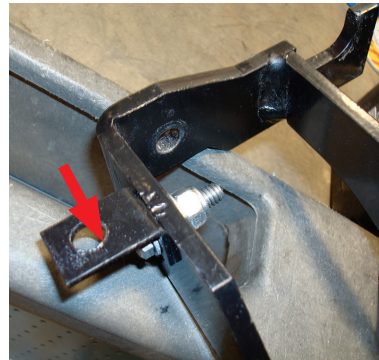
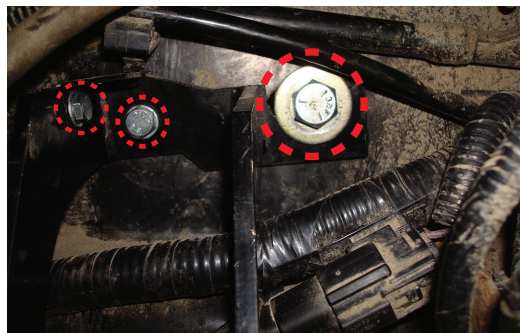

Fig. 13

No matter what side the L-bracket is on, make sure it is installed so the flat side points up when tightening.

DRIVER'S SIDE BRACE INSTALLATION

- Set the left upper brace (E) into the driver's side frame rail. The brace has a small hole that will line up with an existing hole in the frame. Insert the M8-1.25 x 25mm hex cap screw (Q) with an M8 flat washer (Z) through the brace and frame (Fig. 14) and cap with M8 flat washer (Z) and M8-1.25 nylon lock nut (A1). Leave loose at this time.



Driver's side brace shown with supplied hardware in place. Existing fifth wheel hardware which may have been removed may look different.

Fig. 14



BE SURE NOT TO PINCH THE PREVIOUSLY MOVED WIRING OR LINES INSIDE THE LEFT FRAME RAIL.

2. Factory Reese fifth-wheel hitch or no fifth-wheel hitch

If the truck has no fifth-wheel hitch or if it has the standard equipment Reese fifth-wheel hitch that was purchased on the truck from Ford, in the frame there is a slot that is forward of the M8 bolt just installed. Insert the 1/2"-13 x 1 1/2" hex cap screw (O) and 1/2" flat washer (Y) through the brace and frame (from the inside out). Cap with a 1/2" flat washer (Y) and a 1/2"-13 serrated flange lock nut (B1) (Figs. D.11, D.13 & D.14). Do not tighten at this time.

OR

Aftermarket hitch secured WITH hardware on slot side

If the truck has an aftermarket fifth-wheel hitch that has an outer bracket (plate) running alongside of the frame and it used this slot to secure the bracket with existing hardware, install the original fifth-wheel hardware previously removed in the "Prepare the Vehicle" section from the fifth-wheel installation for securing the brace (Fig. D.11). Do not tighten at this time.

OR

Aftermarket hitch secured WITHOUT hardware on slot side

If the truck has an aftermarket fifth-wheel hitch that has an outer bracket (plate) running alongside of the frame and it **does not have** any attaching hardware on the side where the slot in the frame is, it will be necessary to drill a 1/2" hole through the plate using the slot in the frame as a template. Drill the hole as far to the rear of the slot as possible.



CLEAR ANY ELECTRICAL OR HARD LINES FROM THE AREA SO AS NOT TO DAMAGE THEM IN ANY WAY WHEN DRILLING THE HOLE.



It may be necessary to mark and remove the outer bracket (plate) from the side of the frame in order to drill the hole correctly. Reattach once the hole is drilled.

3. Insert a 1/2"-13 x 3" hex cap screw (E1) with a 1/2" flat washer (Y) through the brace, frame and fifth wheel plate previously drilled. Cap with a 1/2" flat washer (Y) and a 1/2"-13 serrated flange lock nut (B1) (Fig. 15). Leave loose at this time.

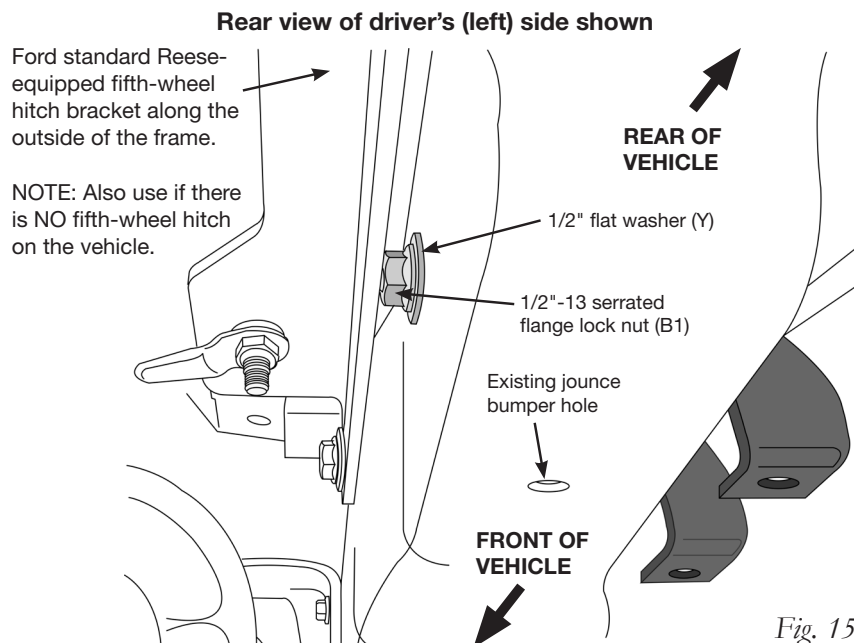
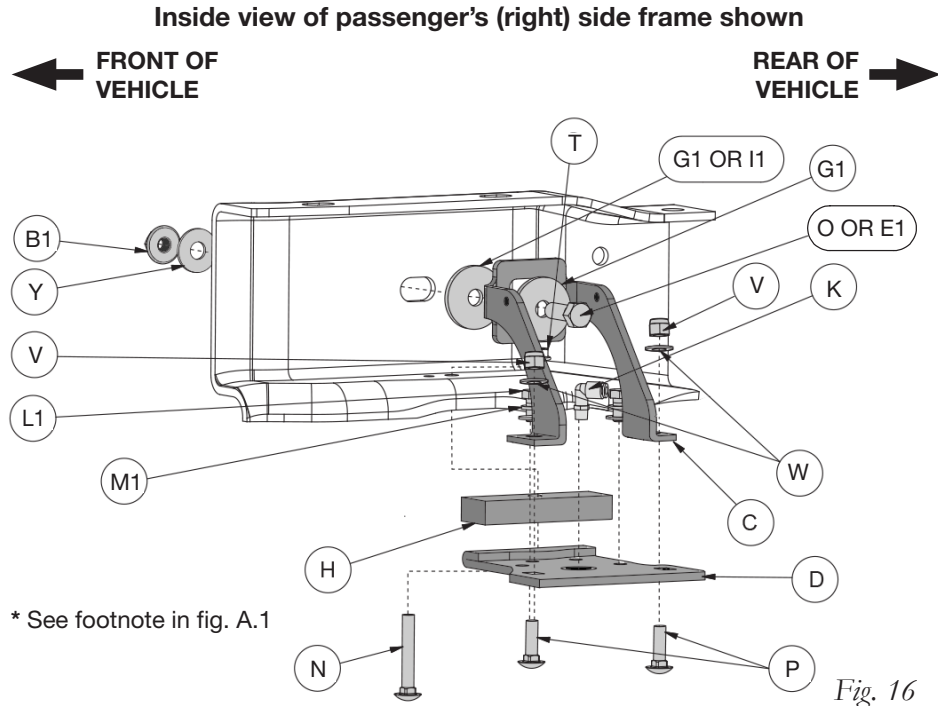

Fig. 15

PASSENGER'S SIDE BRACE INSTALLATION

1. Set the right upper brace (C) into the passenger's side frame rail (Figs. 16, 17 & 18).



For the passenger's side, before inserting the upper brace hardware, make sure that the 1/2" thick washer (G1) or 3/4" washer (I1) is installed in between the brace and frame (see Step 2). Note: The 1/2" thick washer (G1) is not a half-inch thick. It has a 1/2" hole and is a thick washer.

Fig. 17



Passenger's side upper brace shown with hardware supplied in place.

Fig. 18

2. Factory Reese fifth-wheel hitch or no fifth-wheel hitch

For trucks with **no fifth-wheel or the OEM purchased Reese fifth-wheel hitch**, insert the 1/2"-13 x 1 1/2" hex cap screw (O) and 1/2" thick flat washer (G1) through the brace, between the brace and the frame add the 1/2" thick flat washer (G1) then through the frame (from the inside out). **Note:** The 1/2" thick flat washer is not a half-inch thick. It has a 1/2" hole and is a thick washer. Cap with a 1/2" flat washer (Y) and a 1/2"-13 serrated flange lock nut (B1) (Figs. 15 & 16). Do not tighten at this time.

OR

Aftermarket hitch secured WITH hardware on slot side

If the truck has an aftermarket fifth-wheel hitch that has an outer bracket (plate) running alongside of the frame and it used this slot to secure the bracket to the frame with existing hardware, re-install the original hardware previously removed in the "Prepare the Vehicle" section. However, add the 1/2" thick flat washer (G1) or 3/4" flat washer (I1) depending on whether the existing hardware is in between the brace and the frame (Fig. 16).

NOTE

The 1/2" thick flat washer (G1) is not a half-inch thick. It has a 1/2" hole and is a thick washer. Do not tighten at this time.

OR

Aftermarket hitch secured WITHOUT hardware on slot side

If the truck has an aftermarket fifth-wheel hitch that has a bracket (plate) running alongside of the frame and it **does not have** any attaching hardware on the side where the slot in the frame is, it will be necessary to drill a 1/2" hole through the plate using the slot in the frame as a template.

NOTE

It may be necessary to mark and remove the bracket (plate) from the side of the frame in order to drill the hole correctly. Reattach once the hole is drilled.

Insert a 1/2"-13 x 3" hex cap screw (E1) with a 1/2" thick flat washer (G1) through the brace, between the brace and the frame add the 1/2" thick flat washer (G1) then through the frame and fifth-wheel plate previously drilled. **NOTE:** The 1/2" thick flat washer is not a half-inch thick. It has a 1/2" hole and is a thick washer. Cap with a 1/2" flat washer (Y) and a 1/2"-13 serrated flange lock nut (B1) (Fig. 15). Leave loose at this time.

AIR SPRING AND BRACKET ASSEMBLY

1. Set roll plates (I) over the top and bottom of the air spring (J) (Figs. 1 & 19).

NOTE

The radiused (rounded) edge of the roll plate (I) will be toward the air spring so that the air spring is seated inside both roll plates.

2. Install the swivel elbow fitting (K) into the top of the air spring finger-tight. Tighten the swivel fitting one and a half turns.

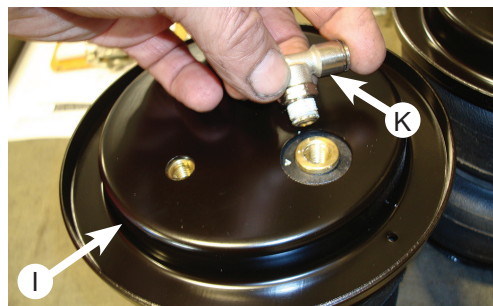

Set roll plate (I) over the air spring and install the fitting (K) as stated. Repeat for both air springs.

Fig. 19

3. Insert a 5/16"-18 x 3/4" carriage bolt (D1) through the square hole in the lower bracket cup (B). Make sure to insert the carriage bolt on the flanged side of the bracket. Set the assembly onto the lower bracket main plate (A) making sure the lower bracket cup is on the flanged side of the bracket (Fig. 20).

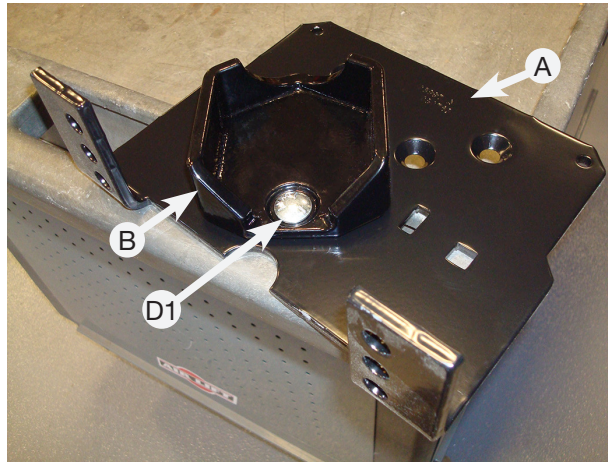

Fig. 20

4. Flip the assembly over and cap the 5/16" carriage bolt with a 5/16" flat washer (H1) and 5/16"-18 nylon lock nut (J1) (Figs. 21 & 22). Tighten the nut only tight enough so that the cup still swivels on the lower bracket main plate (Fig. 23).



Fig. 21



Top of lower bracket

Fig. 22



Bottom of lower bracket

Fig. 23

5. Insert one of the 3/8"-16 x 10" carriage bolts (F1) into the lower bracket assembly previously assembled (Fig. 24). Determine which holes correspond with either side (Fig. 25).

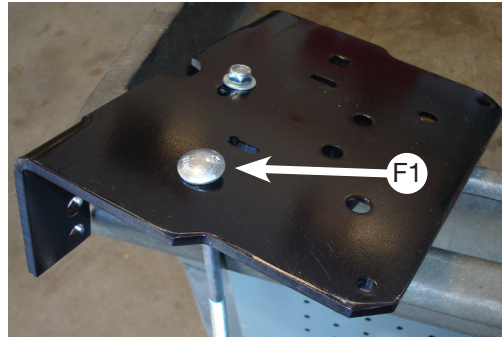

Fig. 24

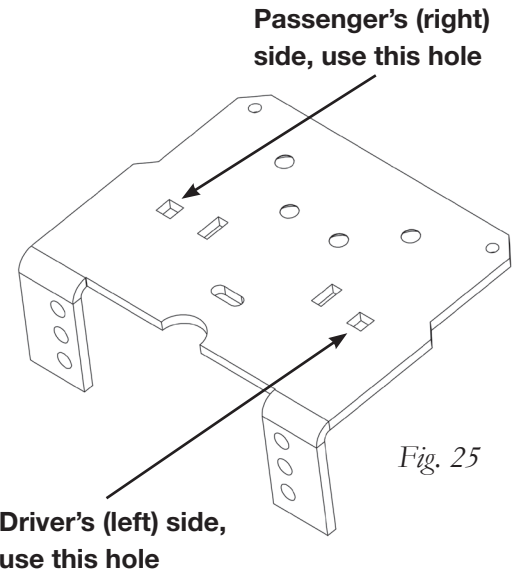

Fig. 25



The 3/8"-16 x 10" carriage bolts will be behind the axle once the assembly is installed on the axle.

6. The lower bracket assembly has two sets of air spring mounting holes, one for the driver's side, and the other for the passenger's. Using the corresponding holes in the lower bracket designated (Figs. 26 & 27), attach the air spring to the bracket using the 3/8"-24 x 3/4" flat-head screws (K1) and torque to no more than 20 lb.-ft. (27Nm).

This slot should be on the opposite side of the air line fitting on the air spring once mounted.



Driver's side air spring mounting holes shown in location to the 3/8"-16 x 10" carriage bolt previously installed. When installing on the air spring, make sure the bracket edge facing you is on the fitting side of the air spring.

Fig. 26

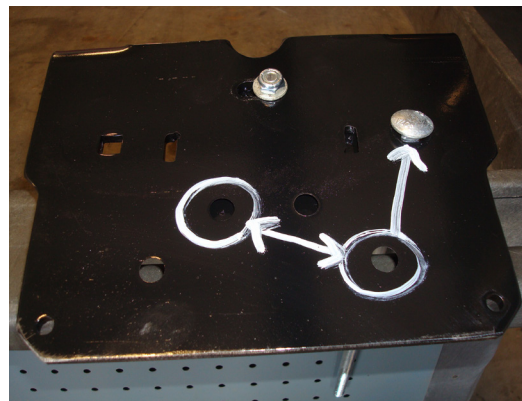

Passenger's side air spring mounting holes shown in location to the 3/8"-16 x 10" carriage bolt previously installed. When installing on the air spring, make sure the bracket edge facing you is on the fitting side of the air spring.

Fig. 27

7. Figure 28 shows the driver's side and passenger's side assemblies.

Driver's side

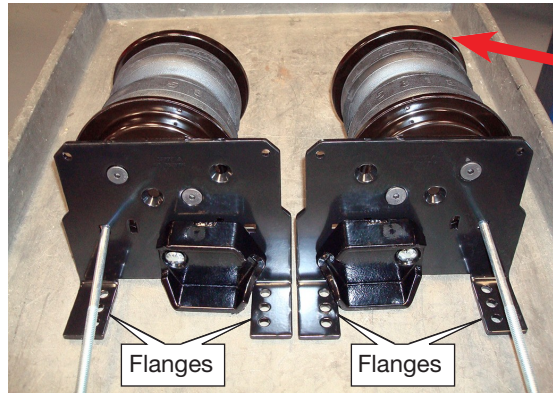

Passenger's side

The air spring fittings must be on this side of the assembly opposite the flanges.

Fig. 28

NOTE The 3/8"-16 x 10" carriage bolts will be behind the axle once the assembly is installed on the vehicle.

8. Set the lower bracket assembly aside. Pick up the driver's side (F) and passenger's side (D) upper brackets (Figs. 29 & 30). Insert two 3/8"-16 x 1 1/4" carriage bolts (P) up through the bottom of the driver's side (F) and passenger's side (D) upper brackets, through the two square holes that are on the corresponding side. Also, insert one 3/8"-16 x 2" carriage bolt (N) through the remaining hole. The head of this carriage bolt will be hidden once the upper bracket is mounted to the air spring.

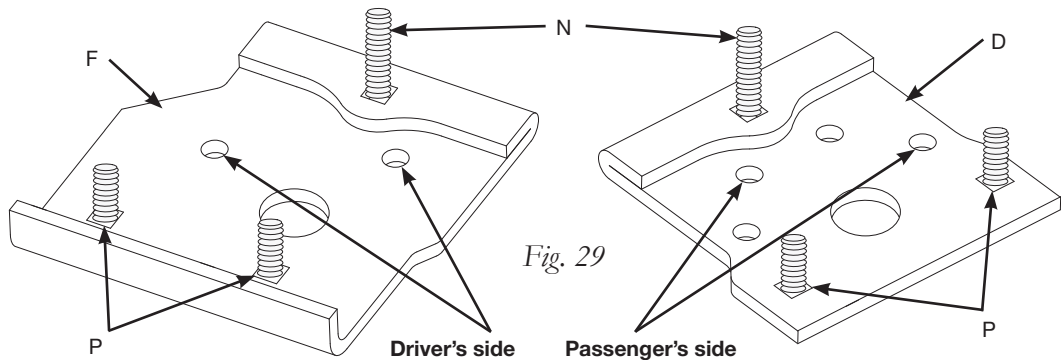
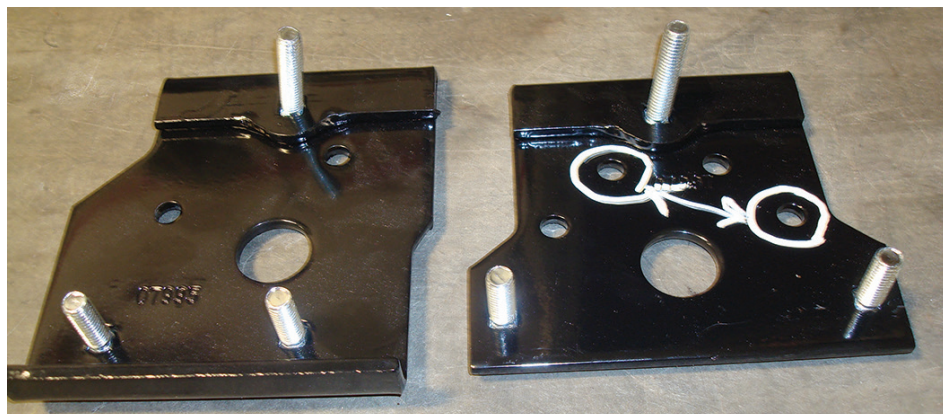

Fig. 29



Driver's side

Passenger's side

Fig. 30

NOTE One of the 3/8"-16 x 1 1/4" carriage bolts (P) will not be covered by the roll plate and may fall out. If so, retain for use in the "Attach the Assemblies to the Frame" section later in this manual.

- Set the driver's side (left) upper bracket onto the driver's side air spring assembly previously assembled, using the holes in the upper bracket designated (Fig. 29), and attach to the air spring with two 3/8" flat washers (W [standard, Ultimate] or X [Pro Series]), 3/8" lock washers (M1) and 3/8"-24 x 7/8" hex cap screws (L1). Torque no more than 20 lb.-ft. (27Nm) (Figs. 31, 32 & 33).

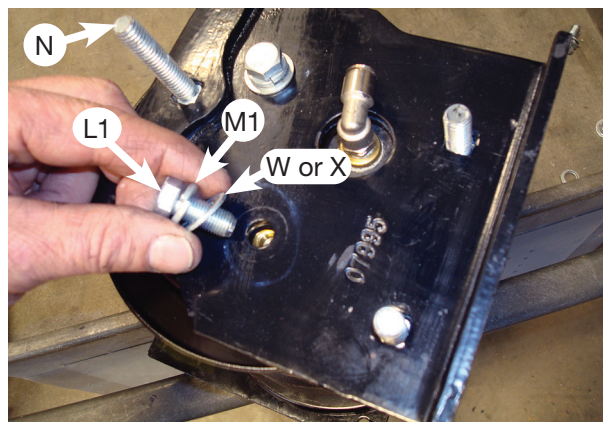
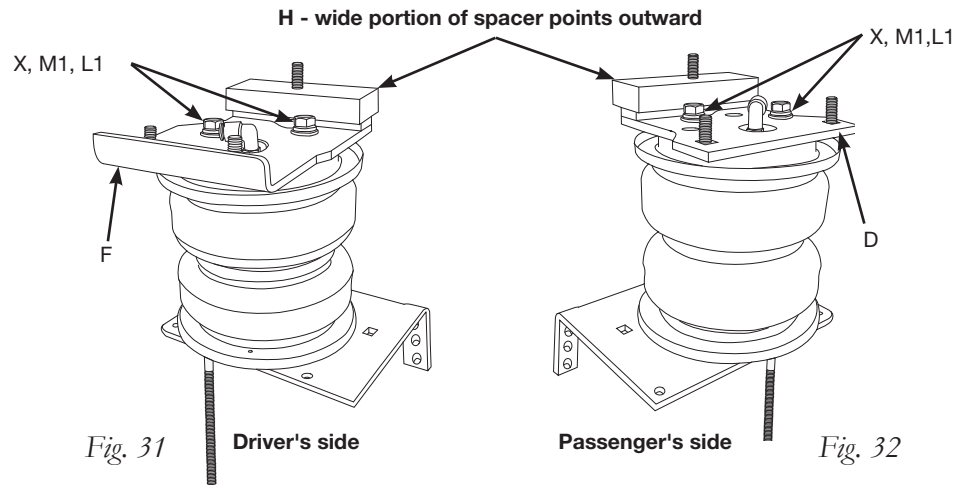

Attach the upper bracket to the air spring assembly with two 3/8" flat washers (W [standard, Ultimate] or X [Pro Series]), 3/8" lock washers (M1), and 3/8"-24 x 7/8" hex-head cap screws (L1).

Fig. 33

- Repeat the above process on the passenger side assembly (Fig. 32).
- Set the spacers (H) over both 3/8"-16 x 2" carriage bolts (Figs. 31, 32 & 34).

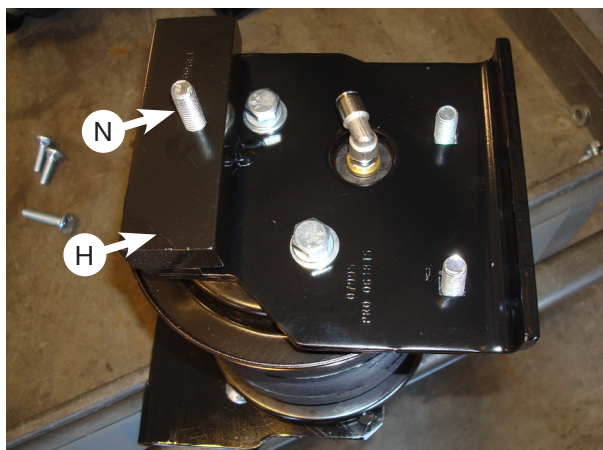

Spacer (H) set on bracket in position. The wide side of the spacer faces the outside of the vehicle.

Fig. 34



The hole in the flat spacer (H) is offset. Install the spacer so that the wide portion faces the outside of the vehicle (Fig. 34).

12. Figure 35 shows the assemblies complete and ready to install.

Driver's side assembly



Passenger's side assembly

Fig. 35

ATTACH THE ASSEMBLIES TO THE FRAME

1. Drop the axle or raise the frame to make room to put the assemblies into position.
2. Set the left (driver's side) assembly onto the jounce bumper strike plate (Fig. 36). Make sure the 3/8"-16 x 10" carriage bolt (F1) on the bottom bracket goes in between the hard brake line and axle on the back side of the axle. Raise the axle just enough to insert the 3/8"-16 x 2" carriage bolt (N) (that is installed in the upper bracket) through the existing jounce bumper hole in the bottom of the frame. At the same time, line up the upper brace into the remaining two carriage bolts in the assembly's upper bracket (Fig. 37). Do this just enough for the carriage bolts to hold the assembly into position in the frame, while resting on the jounce bumper strike plate (Fig. 36).

Existing jounce bumper strike plate

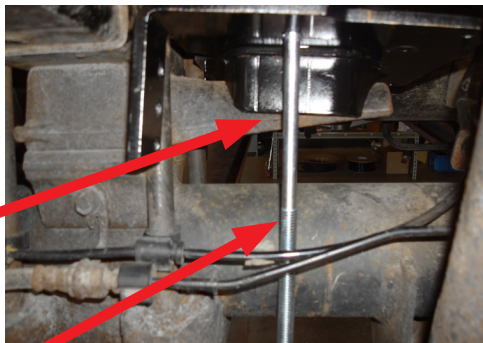

Fig. 36

The long carriage bolt must go in between the axle and the hard brake/ABS line on the driver's side.

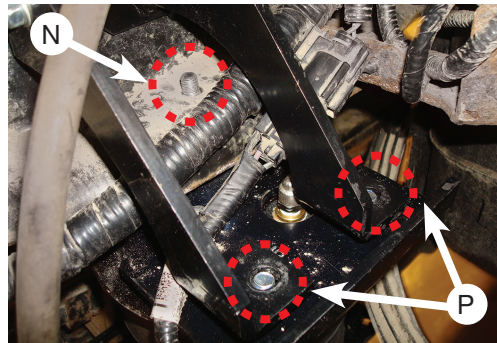

Fig. 37

Raise the axle up while aligning the 3/8"-16 x 2" carriage bolt through the frame and the two 3/8"-16 x 1 1/4" carriage bolts in the upper bracket, through the brace.

3. Set the right (passenger's side) assembly into position on the jounce bumper strike plate the same way the left side was positioned (Fig. 38). Note that the long carriage bolt goes outside of the hard brake line on the passenger's side.



The long carriage bolt goes on the outside (backside) of the hard brake/ABS line on the passenger's side.

Fig. 38

4. Make sure the thick spacer (H) is parallel to the frame and upper bracket (Fig. 39). Finish raising the axle or lowering the frame until the spacer contacts the frame on both sides.

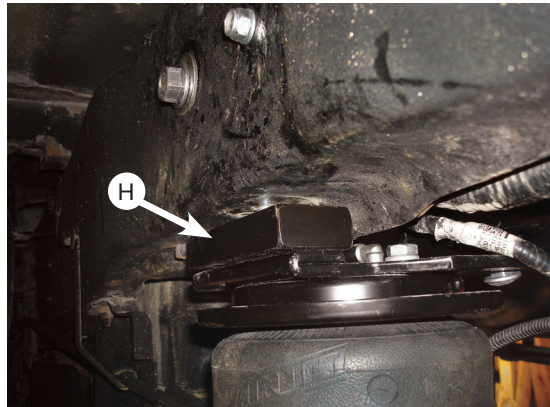

Make sure the spacer (H) is parallel to both the frame and upper bracket. Raise axle or lower frame until the spacer touches the frame on both sides.

Fig. 39

5. Install the 3/8"-16 serrated flange lock nut (T) on the 3/8"-16 x 2" carriage bolt (N) that went through the existing jounce bumper hole and tighten securely on both sides (Fig. 40).



BE SURE NOT TO PINCH THE PREVIOUSLY MOVED WIRING OR LINES INSIDE THE LEFT FRAME RAIL.

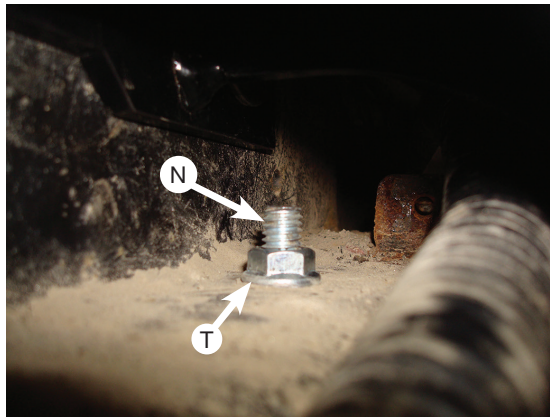

Install the 3/8"-16 serrated flange lock nut (T) onto the 3/8"-16 x 2" carriage bolt (N) that goes through the flange on the frame and tighten.

Fig. 40

6. Cap the 3/8"-16 x 1 1/4" carriage bolts (P) with 3/8" flat washers (W) and 3/8" nylon lock nuts (V) on both sides and torque to 15 lb.-ft. (20Nm) (Fig. 41).

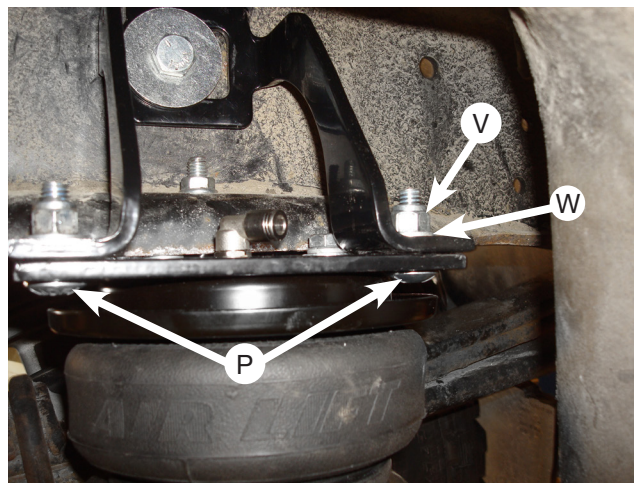

Cap the 3/8"-16 x 1 1/4" carriage bolts with 3/8" nylon lock nuts and torque to 15 lb.-ft. (20Nm) Repeat for both sides.

Fig. 41

7. With the spacers (H) on the upper brackets tight to the bottom of the frame and the braces tight to the upper brackets, tighten the M8 (driver's side only) and 1/2" or 3/4" hardware previously installed, that hold the braces to the frame (Fig. 42). Tighten both sides.

NOTE *If possible, use a thin socket. It helps to pull back the driver's side, mounting hardware (R or E1) as far back in the slot as possible while tightening.*

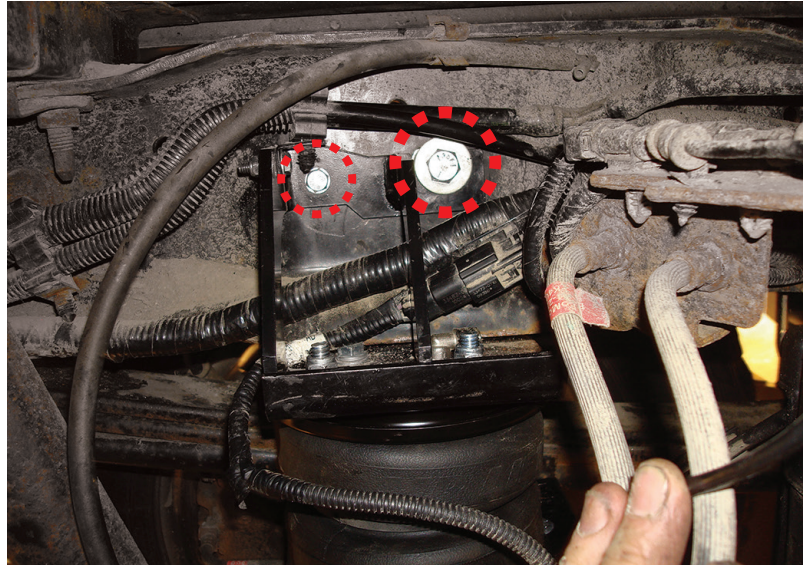

Tighten the M8 hardware and the **1/2" (or 3/4"** if from the 5th wheel hitch hardware) and tighten securely. Repeat for the hardware on the opposite side.

Fig. 42

8. Once the driver's side 1/2" or 3/4" hardware has been tightened, push the wiring harness connector – which was removed in the "Prepare the Vehicle" section – back into the gas/urea tank mounting hole. If the connector broke during disassembly, zip tie it to the bracket (Figs. 5 & 6).
9. If equipped with the emissions line previously loosened from the frame, insert the line holder post into the L-bracket (L) attached to the back leg of the upper left brace (E) (Fig. 43). It may be necessary to move the line holder post forward or back on the lines to line up correctly with the L-bracket hole. Reattach any line holders removed forward or behind the axle, if possible, that were removed to aid in positioning the upper bracket.

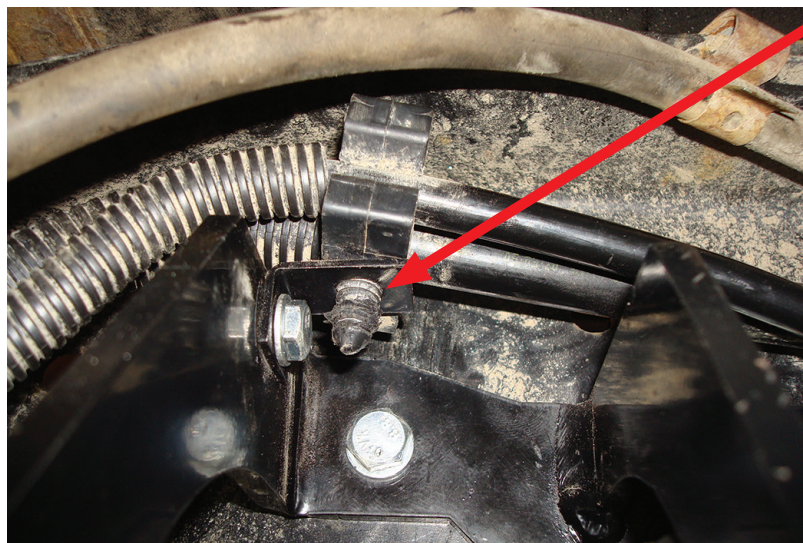

Insert the line holder previously removed into the L-bracket installed on the upper brace as shown.

Fig. 43

ATTACH THE LOWER BRACKET TO THE AXLE

1. Push the lower bracket up against the stock U-bolts so that the legs of the lower bracket are locked into position around the stock U-bolts (Fig. 44). It may be necessary to rotate the lower bracket on the jounce bumper strike plate in order to do this.

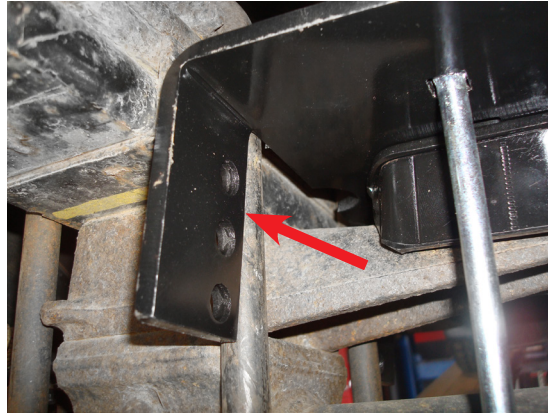

Rotate the lower bracket on the jounce bumper strike plate if necessary and push the bracket up against the U-bolts to put the lower bracket into position.

Fig. 44

2. Make sure the cup on the bottom of the lower bracket is nested onto the jounce bumper strike plate and the flanges of the cup are touching the strike plate on both the front and back side (Fig. 45). If it does not sit on the jounce bumper strike plate correctly, the cup swivels on the main plate. Rotate or move the cup to obtain this condition.



Make sure the cup is seated onto the jounce bumper strike plate forward and behind the axle.

Fig. 45

3. Position the U-bolt (C1) around the leaf spring assembly and insert in the hole closest to the leaf spring stack (Fig. 46). The lower bracket flanges must be locked on the front and rear of the stock U-bolts holding the leaf springs to the axle.



Use closest hole to the leaf spring.

Fig. 46

4. Cap the U-bolts with two 3/8" flat washers (W), and two 3/8"-16 nylon lock nuts (V) and evenly tighten only enough to draw the bracket up against the stock U-bolt at this time (Fig. 47). Repeat for the other side. Make sure the bracket rests against the stock U-bolts (Fig. 48).



Evenly tighten only enough to draw the lower bracket to the Stock U-bolts at this time.

Fig. 47



Bracket must be up against the stock U-bolts and the flanges of the lower bracket must be locked forward and behind the stock U-bolts.

Fig. 48

5. Insert the remaining 3/8"-16 x 10" carriage bolts (F1) through the remaining square hole in the lower bracket (forward of the axle) opposite of the one previously installed during the air spring assembly. Set the clamp bar (G) over the carriage bolts (F1) and cap with two 3/8" flat washers (W) and 3/8" nylon lock nuts (V) (Fig. 49). Repeat for the opposite side. Leave loose at this time.

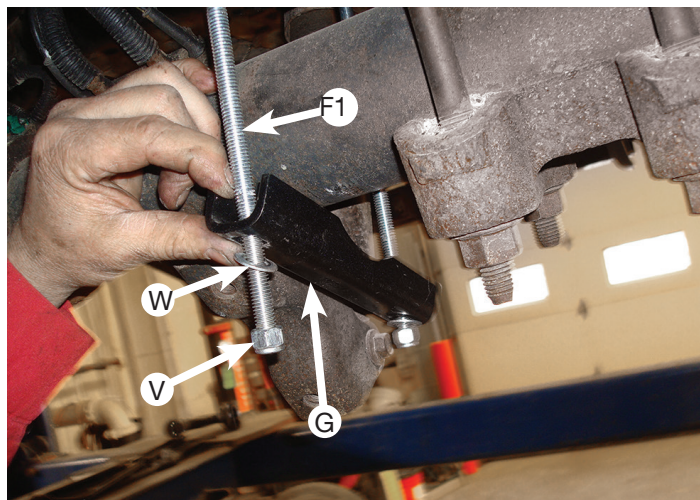

Set the axle clamp bar over the 3/8"-16 x 10" carriage bolts and cap with 3/8" flat washer and 3/8" nylon lock nut. Leave loose at this time.

Fig. 49

6. Tighten the axle clamp bar hardware evenly until it touches the axle (see note below). Torque the axle clamp bar bolts to 16 lb.-ft. (22Nm) (Fig. 50). Repeat for the opposite side. Trim the 3/8"-16 x 10" carriage bolts below the nylon lock nuts if necessary.

NOTE

Do not pinch the hard brake line on the passenger's side while tightening.



It may be necessary on some models to not tighten the axle clamp bar evenly on the right side (passenger's side) so that the clamp bar will clear the hard brake line.

Fig. 50

7. Torque the leaf spring U-bolt hardware to 10 lb.-ft. (14Nm). Repeat for the opposite side. Once tight, the upper and lower brackets will not be parallel and may look like they are out of alignment. This condition will be OK because of the way the lower bracket and upper bracket mounts are designed. Some variance from one unit to another is considered normal.
8. Raise the axle up all the way (if not already done so) and remove the jack stands or equivalent used during the installation.
9. Once the lower bracket hardware is tight, snug the lower mounting plate/swivel cup bracket mounting hardware with an open-end wrench (Fig. 51).
10. Finish installation of the air springs by tying together the soft and hard brake lines that are close to the lower air spring roll plate on the driver's side (Fig. 52).



Tighten lower main plate/swivel cup mounting hardware once the lower bracket is in position and tight.

Fig. 51



Fig. 52

Install the Air Lines

1. Choose the locations for the Schrader valves and drill a 5/16" (8mm) hole, if necessary.

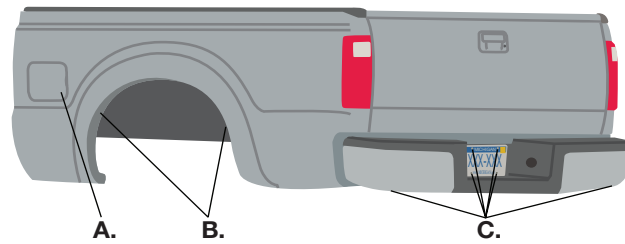

A. Inside fuel tank filler door
 B. Inside rear wheel wells
 C. License plate or rear bumper area



KEEP AT LEAST 6" (152MM) OF CLEARANCE BETWEEN ALL AIR LINES AND THE EXHAUST SYSTEM. AVOID SHARP BENDS AND EDGES.

2. Make clean, square cuts with a razor blade or hose cutter when cutting the air line (AA). Do not use scissors or wire cutters.

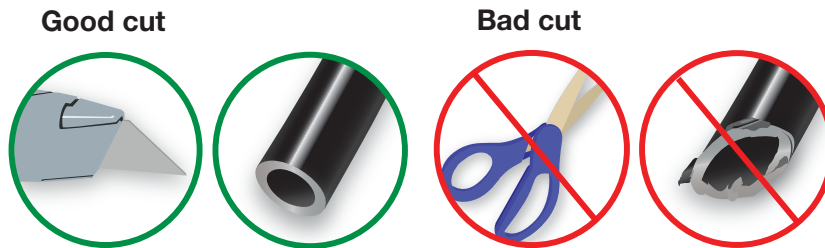

3. Use zip ties (BB) to secure the air line to fixed points along the chassis. Do not pinch or kink the air line. Leave at least 2" (51mm) of slack in the air line to allow for any movement that might pull on the air line. The minimum bend radius for the air line is 1" (25mm).

4. Install the Schrader valve in the chosen location.

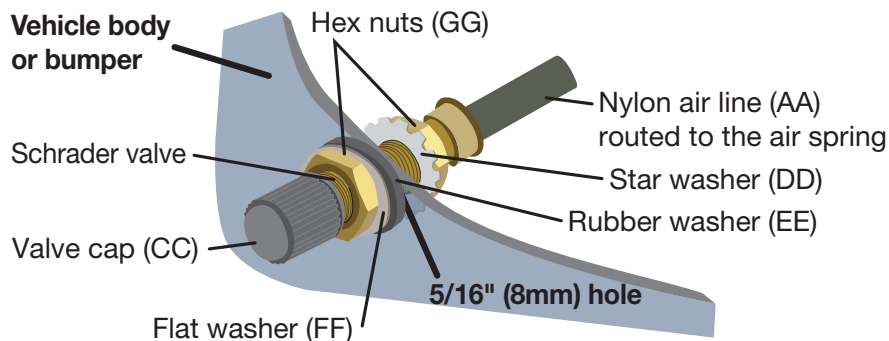

INSTALL THE HEAT SHIELD

Heat shield kit (HH) contents - (1) Heat shield, (1) Air line thermal sleeve and (4) Hose clamps:

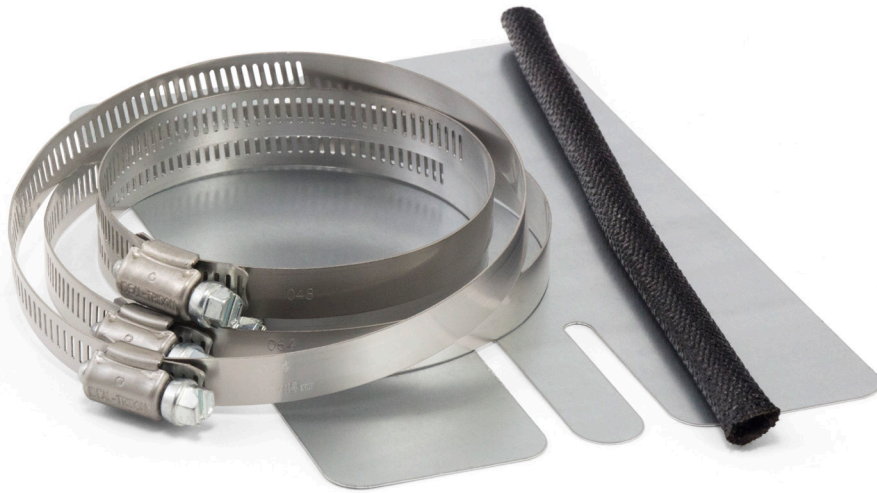

1. Attach the metal heat shield to the exhaust using the hose clamps where it is closest to the air spring. Slide the air line thermal sleeve over the air line and place it where the air line is closest to the exhaust.

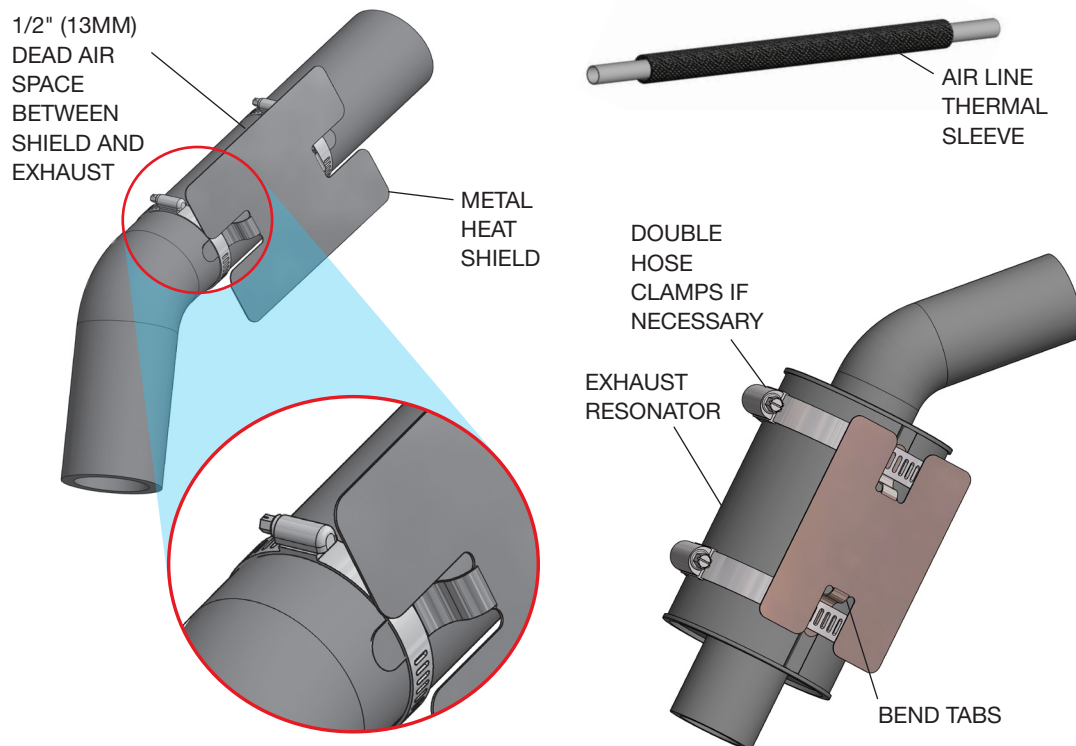

Finished Installation

The following images show the finished installation of both sides.



Back driver's side (left) rear view of the kit installed.



Back center driver's side view of the kit installed.



Back passenger's side (right) rear view of the kit installed.



Back center passenger's side view of the kit installed.

Congratulations!

You are now the proud owner of an Air Lift air suspension system. Enjoy!

Before Operating

INSTALLATION CHECKLIST

- Clearance test** — Inflate the air springs to 40-60 PSI (2.8-4.1BAR) and make sure there is at least 1/2" (13mm) clearance from anything that might rub against each sleeve. Be sure to check the tire, brakes, frame, shock absorbers and brake cables.
- Leak test before road test** — Inflate the air springs to 40-60 PSI (2.8-4.1BAR) and check all connections for leaks. All leaks must be eliminated before the vehicle is road-tested.
- Heat test** — Be sure there is sufficient clearance from heat sources, at least 6" (152mm) for air springs and air lines. If a heat shield was included in the kit, install it. If there is no heat shield, but one is required, call Air Lift customer service at (800) 248-0892.
- Fastener test** — After 500 miles (800km), recheck all bolts for proper torque.
- Road test** — The vehicle should be road-tested after the initial tests. Inflate the air springs to recommended driving pressures. Drive the vehicle 10 miles (16km) and recheck for clearance, loose fasteners and air leaks.
- Operating instructions** — If professionally installed, the installer should review the operating instructions with the owner. Be sure to provide the owner with all of the paperwork that came with the kit.

MAINTENANCE AND USE GUIDELINES

1. Check air pressure weekly.
2. Always maintain normal ride height. Never inflate beyond 100 PSI (7BAR).
3. If the system develops an air leak, use a soapy water solution to check all air line connections and the inflation valve core before deflating and removing the air spring.
4. Upon successful completion of the installation, follow these pressure requirements for the air springs.



**Minimum Recommended
Air Pressure**



Maximum Air Pressure



FOR SAFETY AND TO PREVENT POSSIBLE DAMAGE TO THE VEHICLE, DO NOT EXCEED MAXIMUM GROSS VEHICLE WEIGHT RATING (GVWR) OR PAYLOAD RATING, AS INDICATED BY THE VEHICLE MANUFACTURER.

ALTHOUGH THE AIR SPRINGS ARE RATED AT A MAXIMUM INFLATION PRESSURE OF 100 PSI (7BAR), THE AIR PRESSURE ACTUALLY NEEDED IS DEPENDENT ON LOAD AND GROSS VEHICLE WEIGHT RATING.

Limited Warranty and Return Policy

Air Lift Company provides a Limited Lifetime Warranty* to the original purchaser of its load support products, from the date of original purchase, that the products will be free from defects in workmanship and materials when used on cars and trucks as specified by Air Lift Company and under normal operating conditions, subject to the requirements and exclusions set forth in the full Limited Warranty and Return Policy.

*Full Limited Warranty and Return Policy are available at www.airliftcompany.com/warranty and are subject to change.

WARRANTY REGISTRATION & CLAIMS

- To register your warranty, please visit <https://www.airliftcompany.com/support/warranty/register/>
- To submit a warranty claim, please visit <https://www.airliftcompany.com/support/warranty/submit-claim/>



Thank you for purchasing Air Lift Products!

Need Help?

Contact Air Lift Company Customer Service at (800) 248-0892
or email service@airliftcompany.com.

For calls outside the U.S. or Canada, dial +1 (517) 322-2144.



Air Lift Company • 2727 Snow Road • Lansing, MI 48917 or P.O. Box 80167 • Lansing, MI 48908-0167

Air Lift Company reserves the right to make changes and improvements to its products and publications at any time.
For the latest version of this manual, contact Air Lift Company at (800) 248-0892 or visit airliftcompany.com.