

INSTALLATION INSTRUCTIONS AND PARTS LIST
MODEL 583072, 583078, 583088, 584072, 584078, 584088 O-MEGA II 6" OVAL STEPS
 UNIVERSAL APPLICATION

1. READ INSTRUCTIONS COMPLETELY AND CHECK TO MAKE SURE THAT ALL REQUIRED PARTS (LISTED ON THE SERVICE PARTS LIST) ARE ON HAND BEFORE STARTING THE INSTALLATION.
2. FOLLOW THE INSTRUCTIONS INCLUDED WITH THE SPECIFIC BRACKET PACKAGE THAT YOU ARE USING, TO MOUNT THE BRACKETS TO YOUR VEHICLE.
3. BEFORE ATTACHING THE O-MEGA STEPS TO THE BRACKETS, PLACE THE STEP PADS (ITEM #2) ON TOP OF THE STEP PLATES. USE THE TABLE ON SHEET #2, AS A GUIDE TO POSITION THE STEP PAD FOR YOUR PARTICULAR VEHICLE. WHEN INSTALLING THE PADS ON THE STEPS, DRILL (5) 1/8" HOLE USING THE STEP PAD AS A GUIDE. ATTACH WITH (5) 8-18X1/2" TEK SCREWS (ITEM #6) PROVIDED. REPEAT FOR ALL STEP PADS.
4. INSTALL THE REQUIRED NUMBER OF SQUARE HEAD BOLTS INTO THE DESIGNATED SLOTS IN THE BOTTOM OF THE STEP PLATES.
5. INSTALL THE END CAPS (ITEM #3) AS SHOWN IN *fig. 1*, TIGHTENING THE NUTS TO 5 LB FT.
6. POSITION THE O-MEGA STEP ON THE MOUNTING BRACKETS SO THAT THE SQUARE HEAD SCREWS (ITEM #4) ARE LOCATED IN THE SLOTS OF THE MOUNTING BRACKETS AND THE STEP IS CENTERED, FRONT TO REAR, ON THE VEHICLE. INSTALL 5/16" SERRATED FLANGE NUTS (ITEM #5) ON THE SQUARE HEAD SCREWS (ITEM #4) AND TIGHTEN TO 19 LB FT.

SERVICE PARTS LIST

ITEM	PART NO.	QTY	DESCRIPTION
1	553071	2	EXTRUSION-AL,69.0,OMEGA STP,SILVER
1	553072	2	EXTRUSION-AL,75.0,OMEGA STP,SILVER
1	553073	2	EXTRUSION-AL,85.0,OMEGA STP,SILVER
1	553059	2	EXTRUSION-AL,69.0,OMEGA STP,BLACK
1	553060	2	EXTRUSION-AL,75.0,OMEGA STP,BLACK
1	553061	2	EXTRUSION-AL,85.0,OMEGA STP,BLACK
2	552970	4	ALUM,STP-PAD,BLK,OMEGA-STEP
3	107956	4	CAP-END,PLSTC,2.95 X 6.70
4	106880	24	SCREW-SQ HD,5/16-18 X 1,MAGNIGUARD
5	102680	24	NUT-SERR FLG,HX,SST,WX,5/16-18
6	107958	20	SCREW-PPH,TEK,#8-18 X 1/2",SST,BZP



STEP PAD LOCATION GUIDE

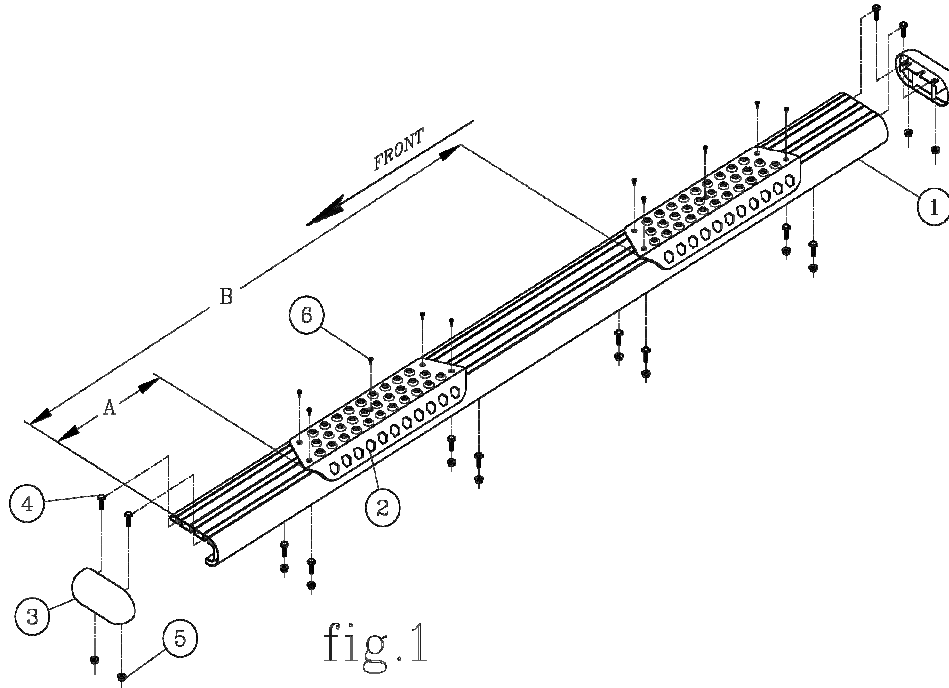

VEHICLE MODEL	PAD A	PAD B
SILVERADO/SIERRA DOUBLE CAB	14-3/4	46-3/4
SILVERADO/SIERRA EXTENDED CAB	14-3/4	41-3/4
SILVERADO/SIERRA CREW CAB	14-3/4	54-1/4
COLORADO/CANYON EXTENDED CAB	10-1/2	43
COLORADO/CANYON CREW CAB	10-1/2	51
AVALANCHE/SUBURBAN/YUKON XL	15-1/4	55-1/4
TAHOE/YUKON	15-1/4	48-1/4
RAM QUAD CAB	10-1/2	46
RAM CREW CAB	10-1/2	48
RAM MEGA CAB	10-1/2	52-1/16
DODGE DAKOTA QUAD CAB	10-1/2	39
DODGE DURANGO	15-1/4	50-1/4
FORD F150 SUPER CAB	18-1/4	46-1/4
FORD F150 SUPER CREW CAB	18-1/4	56-1/2
FORD SUPER DUTY SUPER CAB	14-1/4	42
FORD SUPER DUTY CREW CAB	12	58-1/4
TOYOTA TUNDRA DOUBLE CAB 07+	8-1/4	49-1/4
TOYOTA TUNDRA CREWMAX07+	8-1/4	54-1/4
TOYOTA TACOMA ACCESS CAB	8-1/4	30-1/5
TOYOTA TACOMA DOUBLE CAB	18-3/4	55-1/4

NOTE: THE ABOVE PAD LOCATIONS ARE ONLY SUGGESTIONS AND MAY BE PLACED AT THE PURCHASERS DISCRETION.



INSTALLATION INSTRUCTIONS AND PARTS LIST

MODEL 570757 MEGA STEPS W2W BRACKETS:

2007+ TOYOTA TUNDRA REGULAR & DOUBLE CAB PICKUPS W/ 6.5' & 8.0 BOXES
07+TOYOTA TUNDRA CREW MAX PICKUP 5.5' BOX



1. READ INSTRUCTIONS COMPLETELY AND CHECK TO MAKE SURE THAT ALL REQUIRED PARTS (LISTED ON SERVICE PARTS LIST) ARE ON HAND BEFORE STARTING THE INSTALLATION.
2. ATTACH THE MOUNTING BRACKETS TO THE VEHICLE USING EXISTING MOUNTING HOLES ON THE INTERIOR WALL OF THE ROCKER PANEL. **(NOTE: THE BRACKETS MUST BE PLACE IN THE PROPER POSITION. THEY ARE IDENTIFIED WITH NOTCHES ON THE INBOARD EDGE. [1 NOTCH IS FOR #1 BRACKET, ETC.] #1 WILL BE AT THE FRONT OF THE VEHICLE. SEE FIG. 1).**
 - 2.1 NOTE THAT ON THE REGULAR CAB APPLICATIONS YOU WILL ONLY USE BRACKETS #1 (ITEM #2) AND #3 (ITEM #4) FOR THE CAB MOUNTS.
 - 2.2 POSITION THE BRACKETS ON THE VEHICLE SO THAT BOTH HOLES LINE UP WITH THE THREADED INSERTS IN THE ROCKER PANEL ATTACH THE TOP OF THE BRACKET WITH A M8-1.25 X 25MM ZINC PLATED HEX HEAD CAP SCREW, 5/16" FLAT WASHER AND LOCK WASHER (ITEMS #6, #7 & #8). LEVEL THE BRACKETS AND TIGHTEN THE FASTENERS TO 19 LB FT.
3. ATTACH THE STEP (ITEM #1) TO THE MOUNTING BRACKETS. **(REAR BRACKET MOUNTS IN STEP 4)**
 - 3.1. INSERT FOUR (4) 5/16" SQUARE HEAD SCREWS (ITEM #10) IN THE CENTER SLOT ON THE UNDER SIDE OF THE STEP. AND ONE (1) INTO OUTER SLOT FOR THE BOX BRACKET.
 - 3.2. POSITION THE STEP ON THE MOUNTING BRACKETS SO THAT THE SQUARE HEAD SCREWS ARE LOCATED IN THE SLOTS OF THE MOUNTING BRACKETS AND THE STEP IS CENTERED, FRONT TO REAR, ON THE CAB.
 - 3.3. LOCATE THE STEP, IN AND OUT, AS DESIRED, INSTALL 5/16" SERRATED FLANGE NUTS (ITEM #9) ON THE SQUARE HEAD SCREWS AND TIGHTEN TO 19 LB FT.
4. ATTACH THE W2W BRACKET TO THE LEAF SPRING MOUNT.
 - 4.1 INSERT CLIPPED BOLT (ITEM # 16) INTO THE INBOARD BRACKET (ITEM #15) AND PLACE A NUT (ITEM #18) ON JUST A FEW THREADS LEAVING IT LOOSE FOR NOW.
 - 4.2 HOLD BRACKET UP TO LEAF SPRING MOUNT AND PLACE CLIPPED BOLT INTO OBOURND HOLE. FINGER TIGHT.
 - 4.3 INSERT TOP SCREW (ITEM #17) FROM BEHIND FRAME RAIL THROUGH LEAF SPRING MOUNT AND INBOARD BRACKET AND PLACE NUT (ITEM #18)ON FINGER TIGHT.
 - 4.4 MOUNT OUTBOARD BRACKET (ITEM #14) TO INBOARD BRACKET (ITEM #15) USING (2) SCREWS, WASHERS AND NUTS (ITEMS # 11, 12 &13). MOUNT STEP BOARD (ITEM #1) TO OUTBOARD BRACKET WITH (2) 5/16" SERRATED FLANGE NUTS (ITEM # 9) ON TO SQUARE HEAD SCREWS AND TIGHTEN ALL FASTENERS TO 19 LB FT.

LIVERNE
ISO9001 QS9000 CERTIFIED TRUCK
EQUIPMENT
1200 Birch Street
Brandon, SD 57005
INC.

SERVICE PARTS LIST

ITEM	PART NO.	QTY	DESCRIPTION
1		2	MEGA STEP BOARD ASSEMBLY (SOLD SEPARATELY) LENGTH WILL VARY DEPENDING ON APPLICATION
2	551362	2	BRKT- MTG, STEP, #1, TOYOTA TUNDRA
3	551363	2	BRKT- MTG, STEP, #2, TOYOTA TUNDRA
4	551364	2	BRKT- MTG, STEP, #3, TOYOTA TUNDRA
5	551365	2	BRKT- MTG, STEP, #4, TOYOTA TUNDRA
6	102549	16	SCREW-M8-1.25X25MM,ZP
7	100030	16	WASHER-LOCK, 5/16" ZP
8	100034	16	WASHER-FLAT, 5/16" ZP
9	102680	20	NUT-SERRATED FLANGE, HEX, SST, 5/16-18 UNC
10	106880	10	SCREW-SQUARE HEAD, 5/16-18 UNC
11	106997	4	SCREW HHC,SST,5/16 X 1.00,BZP
12	106998	4	WASHER STL,.38 X .88 X.083,BZP
13	106996	4	NUT FLANGED,SST,5/16"-18,BZP
14	551721	2	BRKT-STEP,REAR,OUTBOARD,W2W
15	551728	1	BRKT-MTG,INBOARD,REAR,LH (SHOWN)
15	551729	1	BRKT-MTG,INBOARD,REAR,RH
16	104934	2	BOLT-CLIPPED HD,7/16-14 X 1.00,ZP
17	100069	2	SCR-HEX HD,7/16-14 X 1.25,ZP
18	103737	4	NUT-HEX,FLANGED 7/16-14,ZP

SERVICE PARTS LIST

MODEL NO. - 570757

LUVERNE LOGO SHOULD BE TOWARD REAR OF VEHICLE

THIS MOUNTS INTO THE OUTER SLOT

1 RIGHT HAND
LEFT HAND

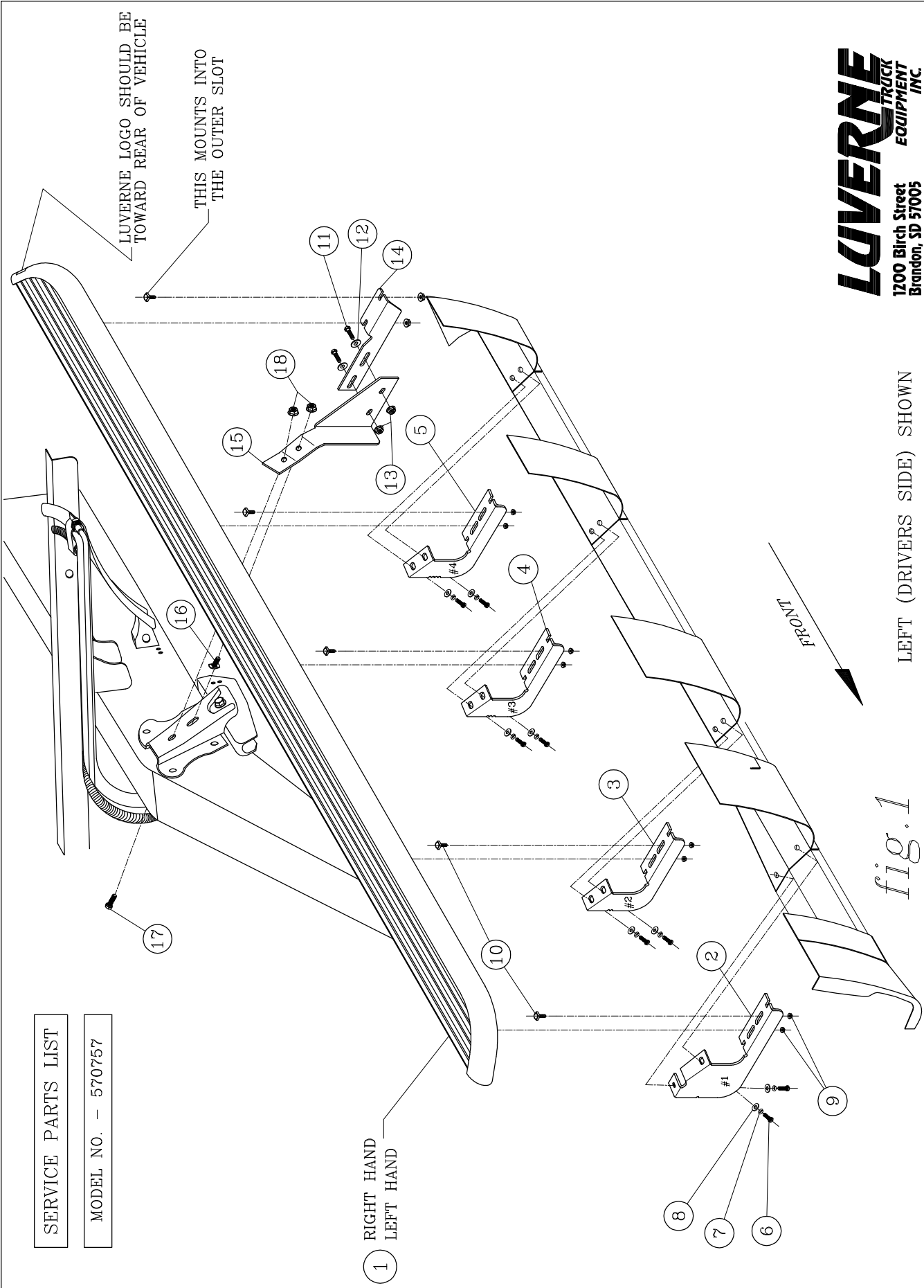

fig. 1

LEFT (DRIVERS SIDE) SHOWN

LUVERNE TRUCK EQUIPMENT INC.
1200 Birch Street
Brandon, SD 57005