



Mud Flap Mounting Bracket Set

Universal, 12", 1" Offset

Mounting Diagram & Instructions

GB756729 (Black Power Coated)

IMPORTANT:

The manufacturer is not responsible for negligent use of vehicle with mud flaps installed, including over-tightening of screws and bolts causing damage to vehicle or mud flaps.

TOOLS REQUIRED:



Electric or re-chargeable
 $\frac{1}{2}$ " or $\frac{3}{8}$ " drill.



$\frac{3}{16}$ " Drill bit



Phillips Screw
Driver



$\frac{3}{8}$ " Socket Driver

KIT CONTAINS:

(1) Upper Panel, DS
Part #755778

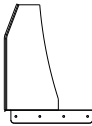

(1) Upper Panel, PS
Part #755779



(2) Back Strip, 12"
Part #755764

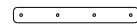

PARTS BAG #755638:

a) (8) Capscrew, Black
#8-32x $\frac{1}{2}$ " Oval HD
Part #012035



b) (8) Tek Screw, SS
 $\frac{1}{4}$ " x 1"
Part #010011



c) (8) Washer, SS
0.28" x 1"
Part #018028



INSTRUCTIONS:

1. Before you install your upper mounts, see the Diagram and parts list for all necessary parts. Start on the Driver's Side.
2. Cut the optional rubber flap to the required height, Minimum 10 – $11\frac{11}{16}$ " (See Diagram #1)
3. Lay upper panel on the cut rubber flap and drill four $\frac{3}{16}$ " (4) Holes from the panel holes thorough the rubber flap. (See Diagram #2)
4. Fasten the panel and the back strip to the rubber flap with the four (4) Capscrews. (See Diagram #3)
5. Square the flap with the tire while holding the flap up against the wheel well and the offset flange tuck underneath the wheel well. (See Diagram #3)
6. Locate the center of the wheel well or wheel flare on the back side of the stainless steel panel and drill four $\frac{3}{16}$ " holes from 'A' to 'D' on the stainless steel panel only.

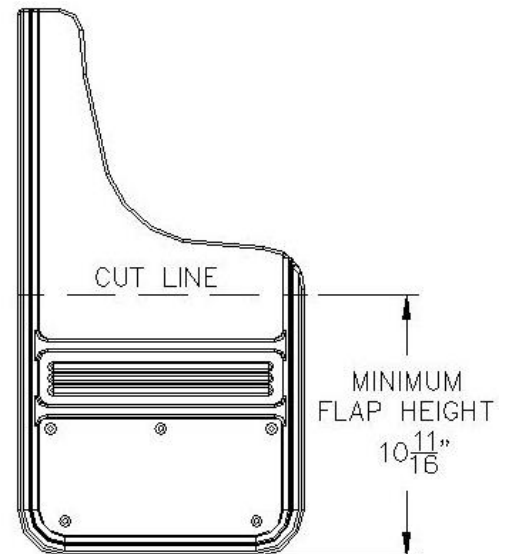

DIAGRAM #1



Note: Drill with caution, do not drill through the wheel well or wheel flare.

7. Cut protective plastic and peel away from the stainless steel.
8. Secure the flap with four flat washers and four tek screws on hole 'A' to 'D'.
9. Repeat procedure for the passenger side. Mud Flaps are now ready to install onto a vehicle.

