

DODGE RAM PICKUP (09) FRONT FENDER FLARES OEM, RUGGED AND BOLT-ON - INSTALLATION INSTRUCTIONS

FF1004

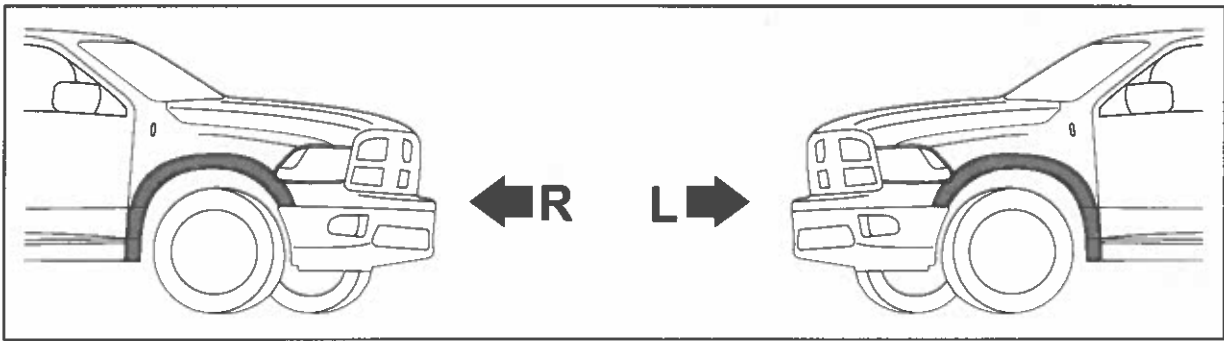

1. Ensure that both left and right hand Fender Flares suit the profile of the vehicle. Note the areas where the Fender Flares come in contact with the vehicle. **NOTE:** Before fitting Fender Flares remove any mouldings, strips or existing flares from the wheel arch. If there is a body side moulding, mark where the moulding is to be cut, alternatively the Fender Flares can be cut to go around the moulding. Be sure to allow enough room for the extrusion.

PAINTING INSTRUCTIONS – If Fender Flares are being painted, do not install edge extrusion until painting is complete. Prior to painting, clean all surfaces to be painted using clean water and a mild detergent, do not use lacquer thinner or any solvent based products. Wipe completely dry. Best results will be achieved by wiping the areas to be painted with a tack rag just prior to painting. Most automotive paints can be applied directly to the Fender Flares, however some may require a primer (check paint manufacturer specifications). Good adhesion will be achieved without sanding. Select a paint (and primer if necessary) that is suitable for rigid plastics PMMA (Acrylic). If using a paint system which requires baking, do not expose the product to temperatures above 70°C (158°F). Do not fit the extrusion or any of the hardware to the Fender Flares until the paint is completely dry.

IMPORTANT: For bolt-on Fender Flares proceed to Step 2. For rugged and OEM Fender Flares proceed to Step 3.

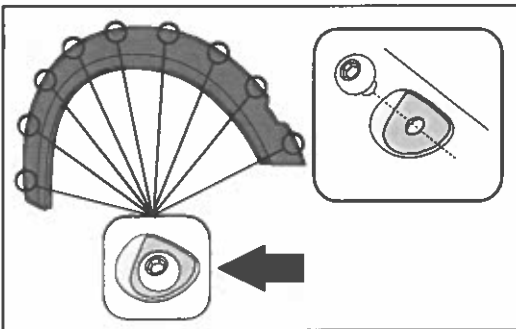

2. Attach 9 extruded plastic bolts. Begin by peeling back the white tape liner from the bottom side of the extruded plastic bolt and press until it snaps into place.

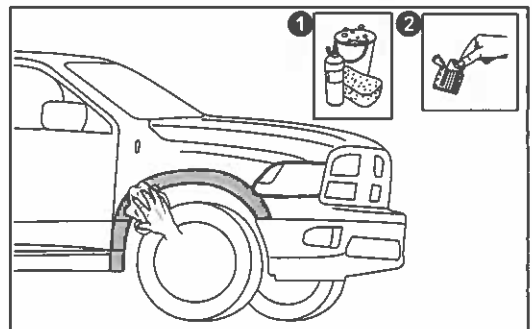

3. Wash the areas of contact on the vehicle and wipe dry both the vehicle and the Fender Flares with a clean cloth. Ensure inside of Fender Flares where extrusion is attached is clean, using the alcohol wipes provided and wipe away any residue with a dry, clean cloth.

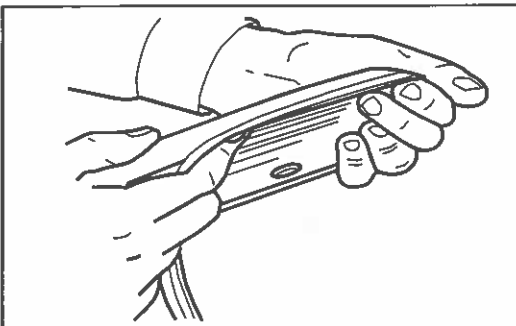

4. Remove approximately 2" (50mm) of the protective liner from the extrusion. Fit the extrusion to the Fender Flare along the edge that comes in contact with the vehicle's body panel.

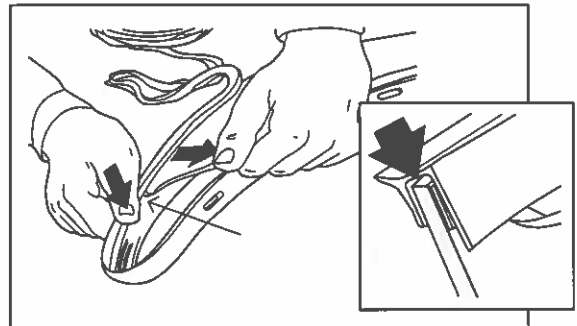

5. Pulling at right angles to the extrusion, remove the liner from the extrusion in small portions and apply thumb pressure to ensure that it adheres to the Fender Flares.

DODGE RAM PICKUP (09) FRONT FENDER FLARES OEM, RUGGED AND BOLT-ON - INSTALLATION INSTRUCTIONS

FF1004

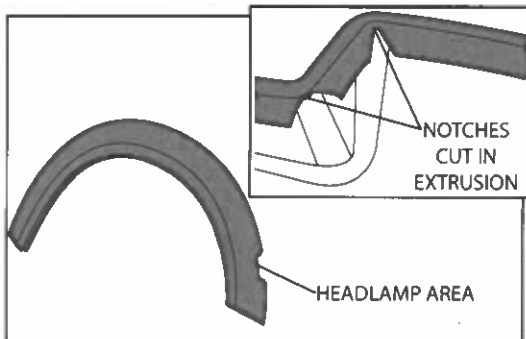

- 6.** Cut notches in extrusion tape to allow it to fit neatly around headlamp area of flare as shown.

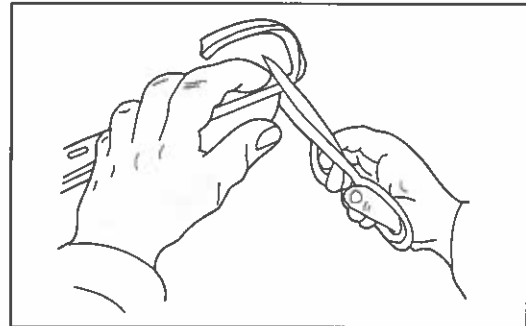

- 7.** Trim any unnecessary extrusion and discard.

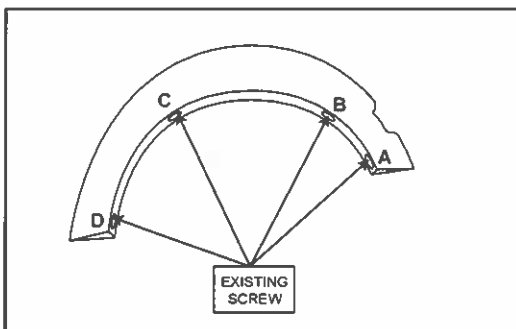

- 8.** Note the correct hardware for positions A, B, C, & D (Right Fender Flare shown).

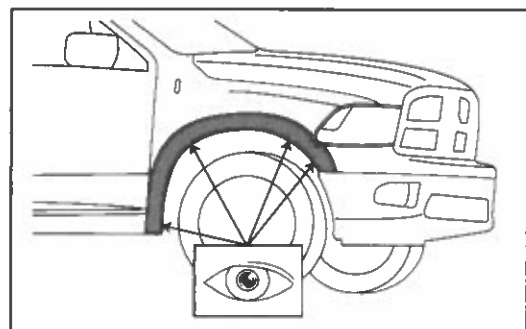

- 9.** Place the Fender Flare on the vehicle into the position of best fit. Note where the slots in Fender Flare at positions A, B, C and D align with the existing screws in the vehicle. Remove Fender Flare.

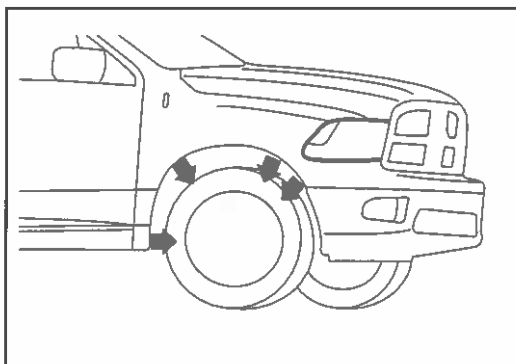

- 10.** Remove the previously noted existing screws and retain for re-installation.

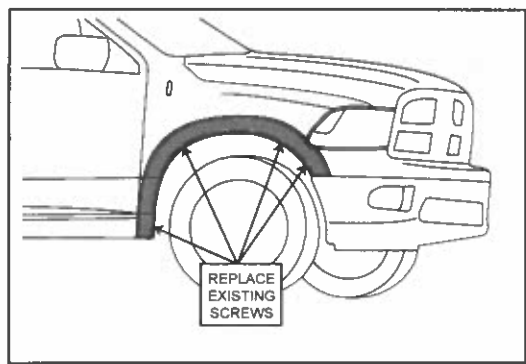

- 11.** Replace the Fender Flare on the vehicle into position of best fit. Complete installation by replacing the previously removed screws at position A, B, C and D, ensuring the Fender Flare is located firmly and extrusion is neat against the vehicle fender. Repeat process for the other side of the vehicle.

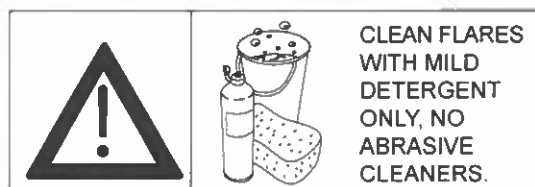

DODGE RAM PICKUP (09) REAR FENDER FLARES OEM, RUGGED AND BOLT-ON - INSTALLATION INSTRUCTIONS

FF1003

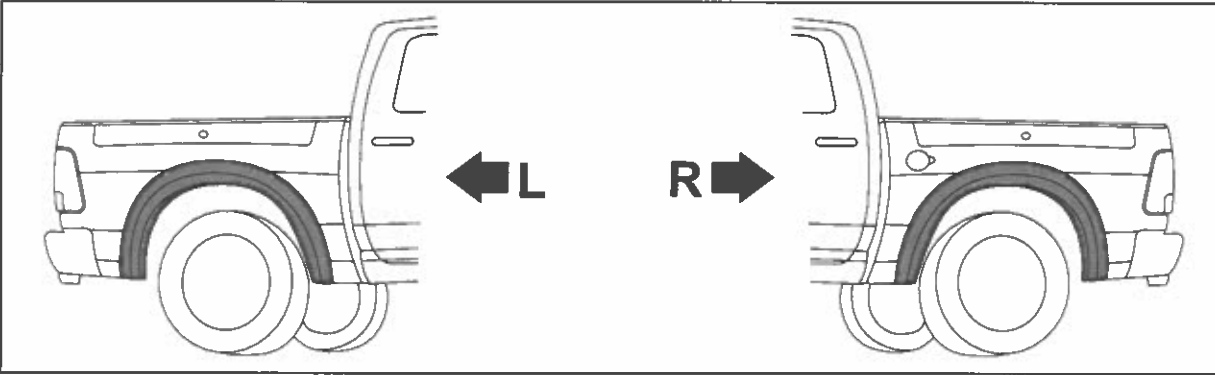

1. Ensure that both left and right hand Fender Flares suit the profile of the vehicle. Note the areas where the Fender Flares come in contact with the vehicle. **NOTE:** Before fitting Fender Flares remove any mouldings, strips or existing flares from the wheel arch. If there is a body side moulding, mark where the moulding is to be cut, alternatively the Fender Flares can be cut to go around the moulding. Be sure to allow enough room for the extrusion.

PAINTING INSTRUCTIONS – If Fender Flares are being painted, do not install edge extrusion until painting is complete. Prior to painting, clean all surfaces to be painted using clean water and a mild detergent, do not use lacquer thinner or any solvent based products. Wipe completely dry. Best results will be achieved by wiping the areas to be painted with a tack rag just prior to painting. Most automotive paints can be applied directly to the Fender Flares, however some may require a primer (check paint manufacturer specifications). Good adhesion will be achieved without sanding. Select a paint (and primer if necessary) that is suitable for rigid plastics PMMA (Acrylic). If using a paint system which requires baking, do not expose the product to temperatures above 70°C (158°F). Do not fit the extrusion or any of the hardware to the Fender Flares until the paint is completely dry.

IMPORTANT: For bolt-on Fender Flares proceed to Step 2. For rugged Fender Flares proceed to Step 3.

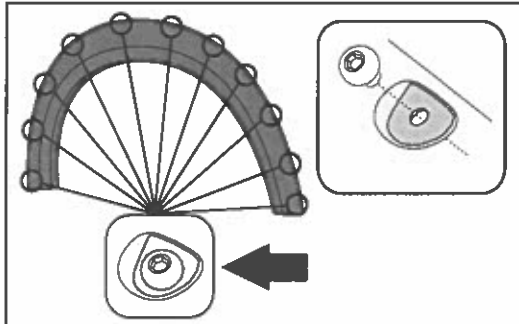

2. Attach 11 extruded plastic bolts. Begin by peeling back the tape liner from the bottom side of the extruded plastic bolt and press until it snaps into place.

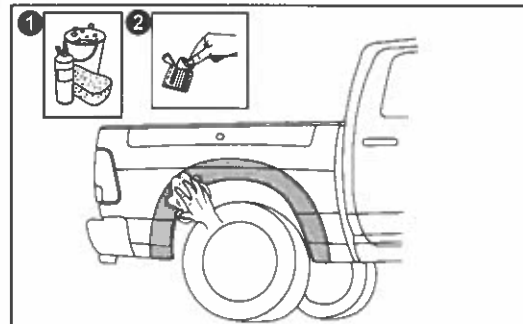

3. Wash the areas of contact on the vehicle and wipe dry both the vehicle and the Fender Flares with a clean cloth. Ensure inside of Fender Flares where extrusion is attached is clean, using the alcohol wipes provided and wipe away any residue with a dry, clean cloth.

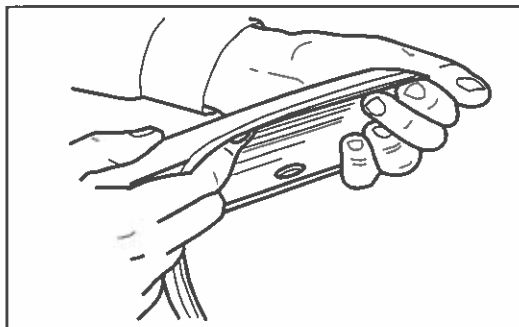

4. Remove approximately 2" (50mm) of the protective liner from the extrusion. Fit the extrusion to the Fender Flare along the edge that comes in contact with the vehicle's body panel.

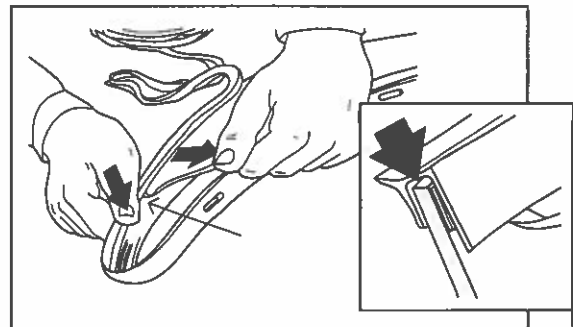

5. Pulling at right angles to the extrusion, remove the liner from the extrusion in small portions and apply thumb pressure to ensure that it adheres to the Fender Flares.

DODGE RAM PICKUP (09) REAR FENDER FLARES OEM, RUGGED AND BOLT-ON - INSTALLATION INSTRUCTIONS

FF1003

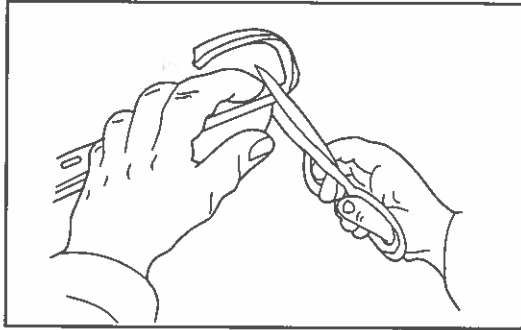

6. Trim any unnecessary extrusion and discard.

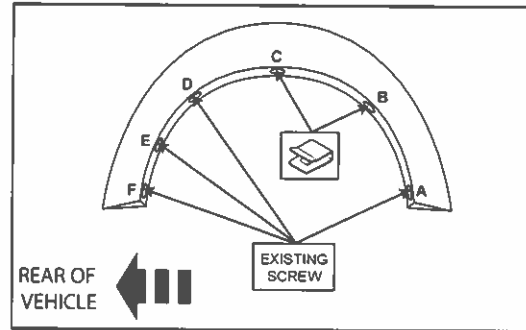

7. Note the correct hardware for positions A, B, C, D, E & F (Right Fender Flare shown).

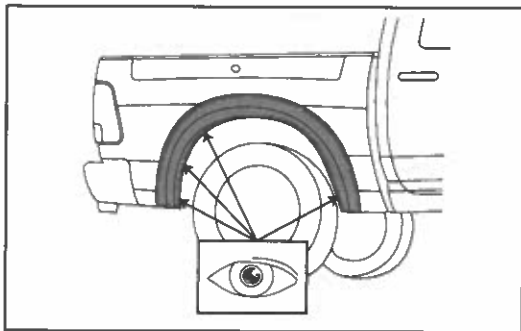

8. Place the Fender Flare on the vehicle into the position of best fit. Note where the slots in Fender Flare at positions A, D, E and F align with the existing screws in the vehicle. Remove Fender Flare.

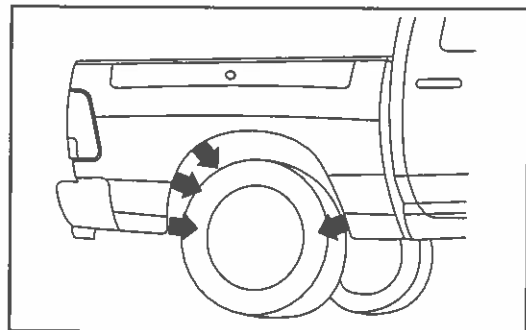

9. Remove the previously noted existing screws and retain for re-installation.

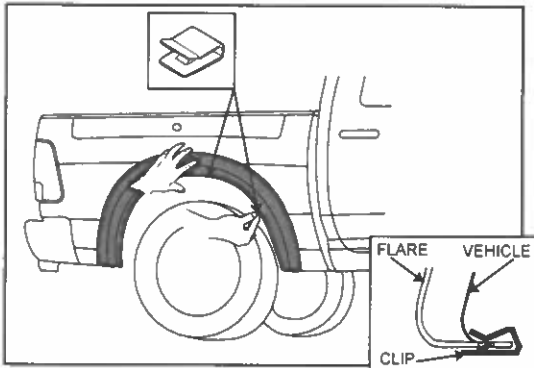

10. Replace Fender Flare on the vehicle into position of best fit. Take the supplied snap clips and fix them into positions B and C, as shown, ensuring the notch in clip locates securely into the slot in the Fender Flare.

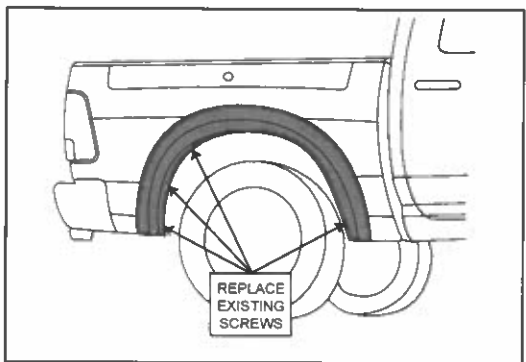

11. Complete installation by replacing the previously removed screws at position A, D, E and F, ensuring the Fender Flare is located firmly and extrusion is neat against the vehicle fender. Repeat process for other side of the vehicle.



CLEAN FLARES WITH MILD DETERGENT ONLY, NO ABRASIVE CLEANERS.