

2017-2019 Ford SuperDuty Regular Cab - *Behind-the-seat Storage* Fits DU-HA Part Number

Installation Instructions:

20115

- 1 Flip and slide the seats forward so you can gain access behind the seats.
- 2 Remove the Jack and Jack Tools. Set the DU-HA (A) in the truck behind the seats. The notched area on the bottom of the DU-HA will fit around the Jack mount that is on the floor. The hole on the drivers side should line up with the insert for the jack tools. You have 3 options for anchoring the DU-HA into your truck. **Option 1** is to use a Self-Tapping Screw; use this option if you want your DU-HA permanently attached in your truck. **Option 2** is to use a Jack-Nut; use this option if you want to be able to remove and re-install your DU-HA in your truck. **Option 3** is to use a thru-bolt; use this option for a more secure permanent installation. Once you have the DU-HA in the desired position secure the DU-HA to the truck using one of the three anchoring options. After installed re-install the Jack in the DU-HA.



3 Anchoring Option 1: Self-Tapping Screw

Tools Needed: // Socket – 1/4" // Socket Wrench or Drill

Warning: Before drilling into the truck floor make sure the area where you are going to drill through is clear of any electrical wiring, fuel lines, tanks, and reservoirs. You will have to look under the vehicle to make sure there are no obstructions at the hole locations.

Insert the Self-Tapping Screw (D) through a Washer – 1/4" (H) and the pre-drilled hole on the passenger side in the bottom of the DU-HA and screw through the carpet or vinyl and into the floor of the truck using a 1/4" Socket and Drill. DO NOT over-tighten. Secure the drivers side using an M8 x 30mm bolt (K) and 1/4" washer (H) by threading into the insert for the Jack Tools and tighten with a 13mm wrench.

4 Anchoring Option 2: Jack-Nuts

Tools Needed: // Drill // Nail or Sharp Punch
 // Socket – 7/16" // 7/16" Drill Bit // Hammer
 // Socket Wrench // Pliers // 13mm Wrench
 // Phillips Screwdriver – #3 // Jack-Nut Friction Wrench (supplied)

Warning: Before drilling into the truck floor make sure the area where you are going to drill through is clear of any electrical wiring, fuel lines, tanks, and reservoirs. You will have to look under the vehicle to make sure there are no obstructions at the hole locations.

- A With the DU-HA set in your desired position, mark the hole in the bottom of the DU-HA on the truck floor using a nail or sharp punch, on the passenger side only. Make sure the hole on the drivers side lines up with the insert in the truck for the jack tools. You will need to poke through the carpet and make a mark on the metal floor of the truck. Next remove the DU-HA and pull back the carpet or vinyl flooring to expose the metal floor. Find the previously made mark and drill a 7/16" hole.
- B Prior to installing the Jack-Nut-1/4" (E), hold the Jack-Nut with a pliers, and using the phillips screwdriver, make a hole through the rubber on the Jack-Nut by pressing and twisting into the rubber on the head of the Jack-Nut-1/4" (E). Next insert the Bolt Hex Head – 1/4" x 2-1/2" (F) through the hole in the Jack-Nut Friction Wrench (J) and thread all the way into the Jack-Nut-1/4" (E). Place the Jack-Nut-1/4" (E) in the drilled hole (*may need a hammer to tap into hole*). Secure the Jack-Nut to the vehicle by tightening the Bolt Hex Head – 1/4" x 2-1/2" (F) using a Socket 7/16" and Socket Wrench, press firmly on the Jack-Nut Friction Wrench (J) and tighten Jack-Nut – 1/4" (E) until you see the rubber on the Jack-Nut starting to get squished. Do not over tighten (max torque = 41 in/lbs). Remove the bolt from the Jack-Nut-1/4" (E).

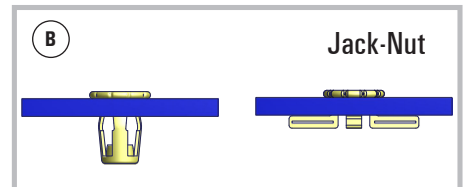
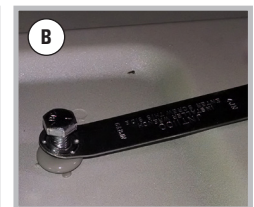
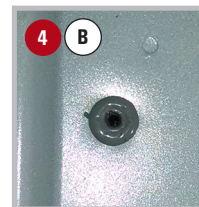
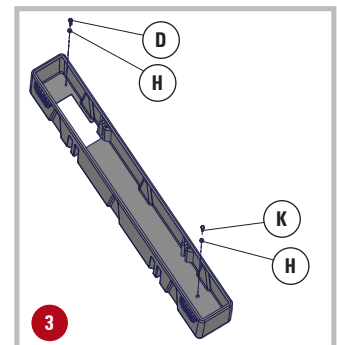

Note: Jack-Nut Friction Wrench is only used to install Jack-Nuts. It does not take a lot of torque to break a Jack-Nut so it is best to use a 7/16" Socket and Socket Wrench. If using a drill with a 7/16" Socket, be very careful not to over tighten and strip out the Jack-Nut.

2017-2018 Ford SuperDuty Regular Cab – *Behind-the-seat Storage* Fits DU-HA Part Number 20115

4 Anchoring Option 2: Jack-Nuts – *Continued*

- C Place the DU-HA back into the truck and position it so the Jack-Nut lines up with the hole in the DU-HA. Secure the DU-HA to the truck using Bolt Hex Head – 1/4" x 2-1/2" (F), Washer – 1/4" (H) and thread into Jack-Nut – 1/4" (E). DO NOT over tighten. Secure the other end of the DU-HA in the truck using an M8 x 30mm bolt (K) and 1/4" washer (H) by threading into the insert for the Jack Tools.

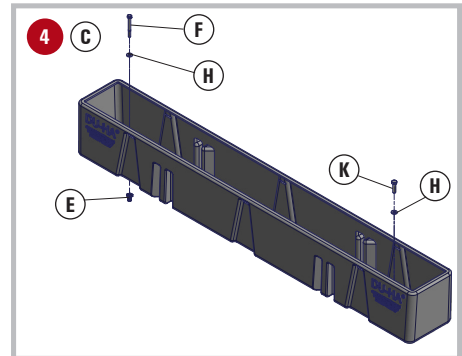

5 Anchoring Option 3: Thru-Bolt – Note: This will require 2 people since you will have to go under the truck to tighten the bolts.

Tools Needed: // Hammer // Nail or Sharp Punch // Socket – 7/16"
// Socket Wrench // 5/16" Drill Bit // Wrench – 7/16" // Drill // 13mm Wrench

Warning: Before drilling into the truck floor make sure the area where you are going to drill through is clear of any electrical wiring, fuel lines, tanks, and reservoirs. You will have to look under the vehicle to make sure there are no obstructions at the hole locations.

With the DU-HA in the truck (make sure the hole on the drivers side lines up with the insert for the Jack Tools) mark the hole in the bottom of the DU-HA on the passenger side onto the floor of the truck using a nail or sharp punch and hammer. Remove the DU-HA and drill a 5/16" hole at the previously marked location. Place the DU-HA back in the truck and secure with one Bolt Hex Head – 1/4" x 2-1/2" (F), two Washers – 1/4" (H), one Lock Washer – 1/4" (I) and one Nut – 1/4" (G), using Socket – 7/16", Socket Wrench and Wrench – 7/16". Secure the drivers side using an M8 x 30mm bolt (K) and 1/4" washer (H) by threading into the insert for the Jack Tools and tighten with a 13mm wrench.

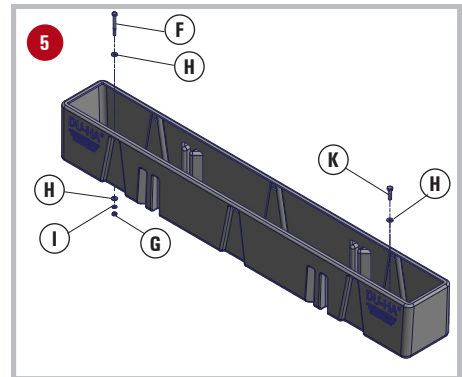

6 Foam Organizer / Gun Holders / Stiffeners

Place each Foam Organizer – Gun Rack (B) / Stiffener (C) assembly into the channel slots in the side walls of the DU-HA (A), facing opposing directions.

Note: You may have to flex the assembly to get it into place.

(Hint – Stock of gun should rest in large groove; barrel should rest in small groove.)

Note: With the jack installed in the Du-ha you will not be able to use the divider gun rack on the passenger side. In order to use it you will need to store the jack in a different location. The Jack Tools can be set in the DU-HA but will not be able to be attached to the floor.



Safety Instructions:

Warning: Make sure the DU-HA is secured in the vehicle according to installation instructions. Do not store explosives or hazardous materials in the DU-HA.

Do not place loaded guns in the DU-HA. For further instructions refer to truck owner's manual or contact DU-HA, Inc.

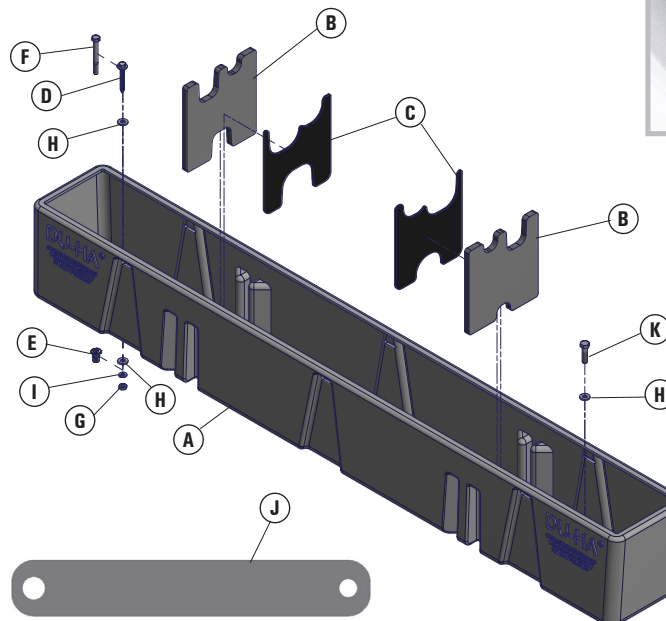

Part	Description	Qty
A	DU-HA Storage Unit	1
B	Foam Organizer / Gun Rack	2
C	Plastic Stiffener	2
D	Self-Tapping Screw	1
E	Jack-Nut – 1/4" (1-extra)	2
F	Bolt Hex Head – 1/4"x2-1/2"	1
G	Nut – 1/4"	1
H	Washer – 1/4"	3
I	Lock Washer – 1/4"	1
J	Jack Nut Friction Wrench	1
K	Bolt Hex Head - M8 x 30mm	1