

I-SHEET NUMBER: INST-00199
 PART NUMBER: ALL MODELS
 PRODUCT: HOOP STEP
 APPLICATION: 09-14 FORD F-150 QC CC

HARDWARE DESCRIPTION		QTY.
HWKT- 07172X		
CARB-07168X	3/8"-16 1"L CARRIAGE BOLT	6
FLTW-00663	3/8" X .406" ID X .75" OD FLAT WASHER	6
FLNT-00664	3/8-16 GRADE 5 STEEL FLANGE NUT	6
CLIP-00645X	5/16"-18 X 9/16" BARREL CLIP	6
FW-00006	5/16 FLAT WASHER,	6
92865A583	5/16"-18 1"L HEX HEAD CAP SCREW	6
PARTS INCLUDED		QTY.
DRIVER SIDE		
PASSENGER SIDE		



N-FAB NERF STEP SYSTEM

STEP 1: Identify driver side step.

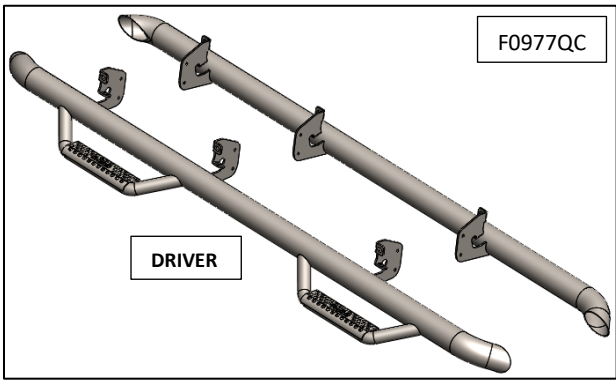
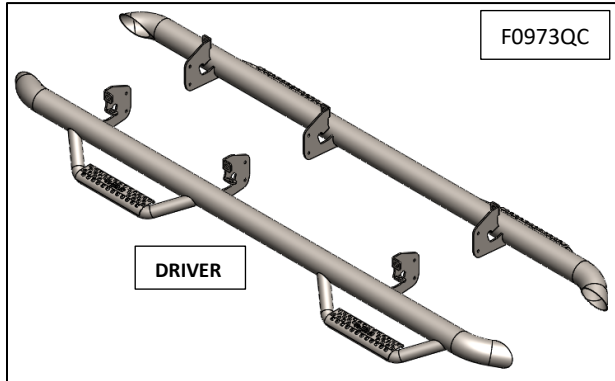

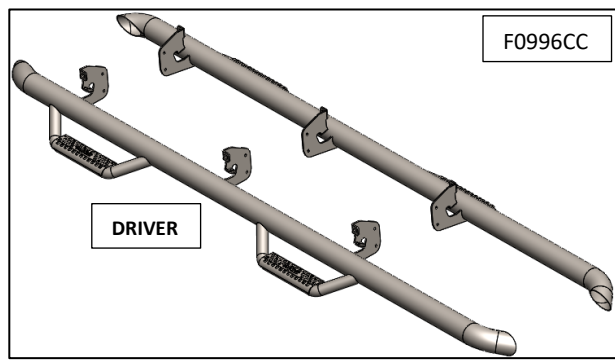
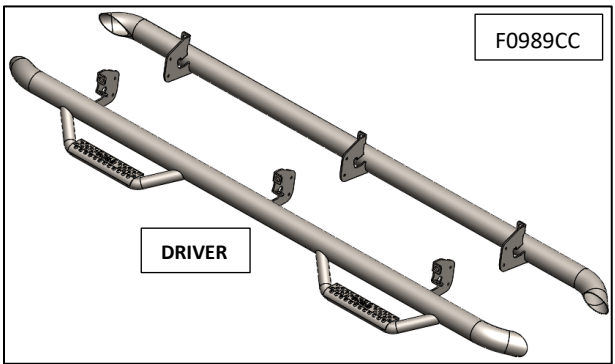
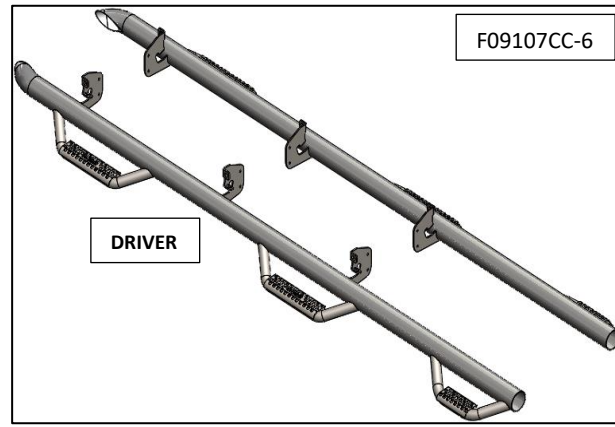
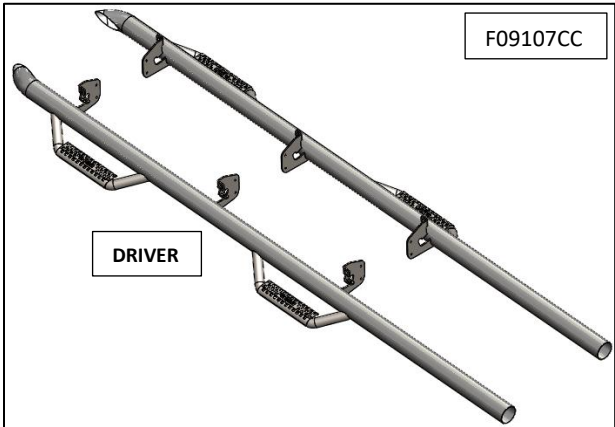
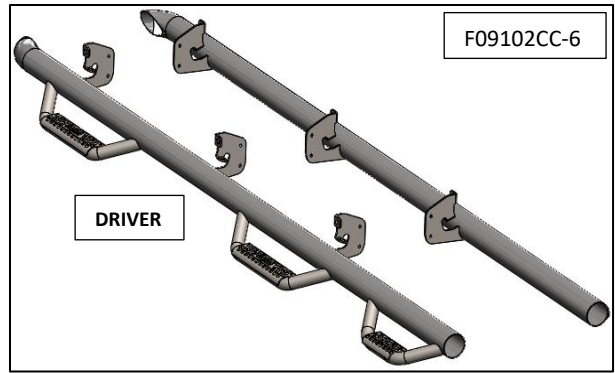
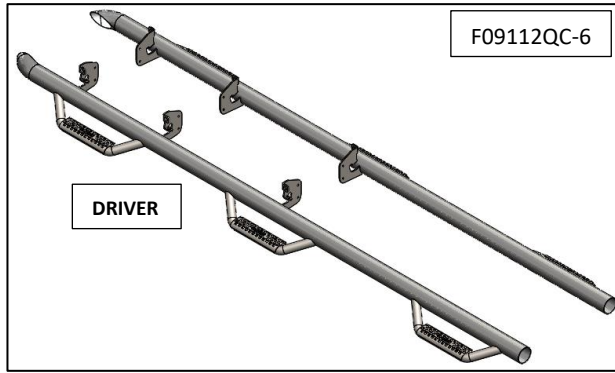
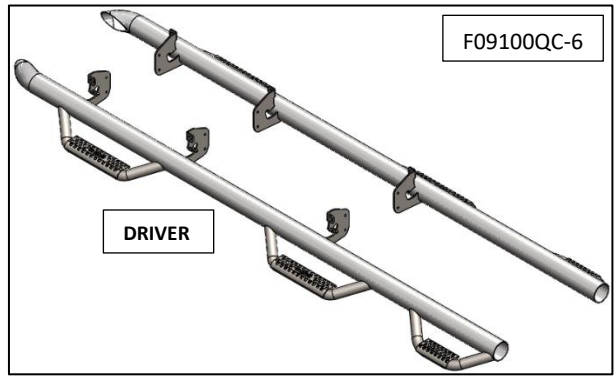
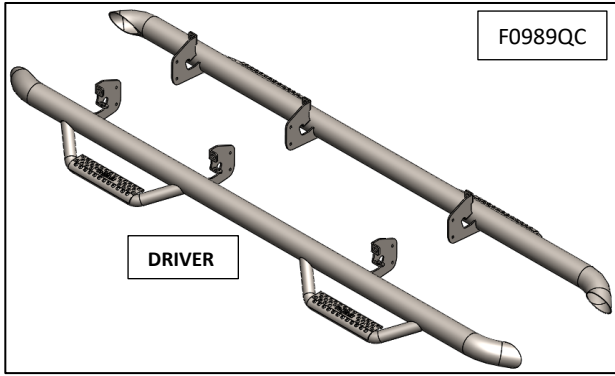

I-SHEET NUMBER: INST-00199
 PART NUMBER: ALL MODELS
 PRODUCT: HOOP STEP
 APPLICATION: 09-14 FORD F-150 QC CC

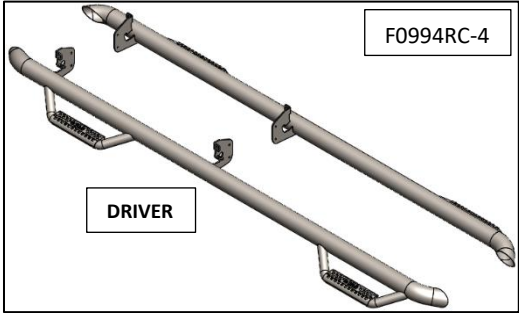
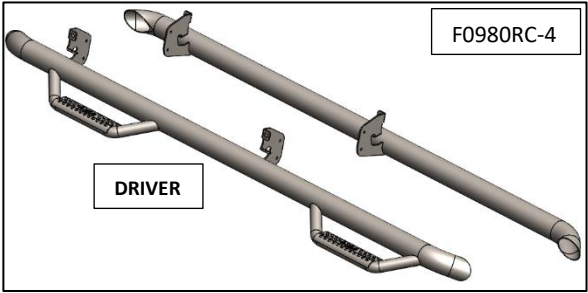
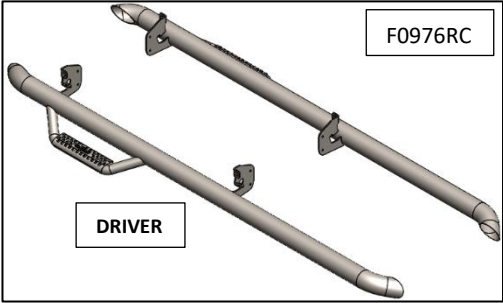

Step 2: Insert the supplied 5/16" U-clips in the upper location in each (x3) mounting position.

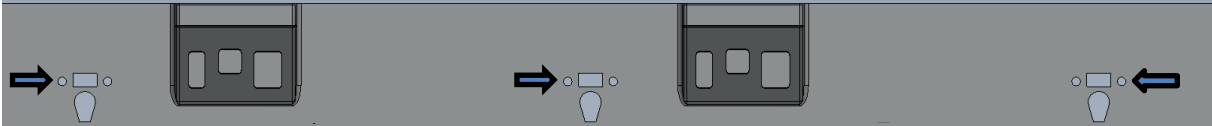

Step 3: Carefully raise step into place aligning brackets to each mounting position. Use the supplied 5 1/6" hex bolt, 5 1/6" washer and 5 1/6" hex nut and hand tighten all x3 upper mounts.
Step 4: Next, install the supplied 3/8"x3/4" carriage bolts, 3/8" washers and 3/8" nuts in all x3 lower mounts and leave loose.
Step 5: Tighten upper mounts first then pinch weld bolts. Torque to 20ft./lbs. to secure steps to the truck.
Step 6: Repeat steps 2-5 with passenger side step.

