

IMPORTANT:

Manufacturer is not responsible for negligent use of vehicle with mud flaps installed, including over-tightening of screws and bolts causing damage to vehicle or mud flaps.

TOOLS REQUIRED-

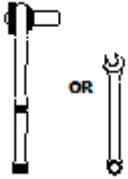

7/16" Open Wrench or
Socket Wrench



1/4" Socket Driver



T15 Torx
Bit

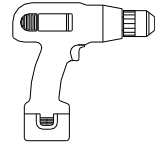

Electric or Rechargeable
Drill

FLAPS

(1) Flap Assy Upper
Front, DS
Part #771139

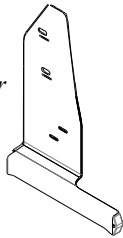

Please note: There will be a plastic piece in the upper mount channel. Please remove and discard.

(1) Flap Assy Upper
Front, PS
Part #771140

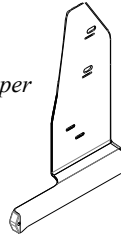

(2) Rubber Flap
Universal
12" x 10-3/4"

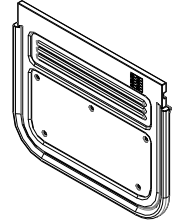

(1) Nylon Cap
Driver Side
Part #080642
(Assembled on Upper Mount)

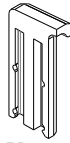

(1) Nylon Cap
Passenger Side
Part #080643
(Assembled on Upper Mount)

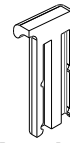

PARTS BAG # 771142

a) (4) Capscrew
1/4"-20UNC x 5/8" SS, ox.
Part #014071



b) (2) Capscrew
1/4"-20 x 1.5" SS, ox.
Part #014074



c) (4) Screw, Sheet Metal, Blk Ox.
1/4" Hex Washer Head, #8-18x1.25"
Part #016061



d) (8) Washer, Flat
0.281" x 1", SS, oxid.
Part #018069



e) (2) Washer, Flat
0.203" x 1", 18g, SS, oxid.
Part #018070

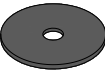

f) (2) Offset Washer
0.203" x 1"
Part #018080

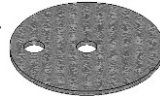

g) (2) Washer, Lock
1/4" Helicoil SS Ox.
Part #024012



h) (2) Hex Nut
1/4"-20 SS, Ox.
Part #025038



i) (2) Washer, Nylon
0.265" x 0.625" x 0.06"
Part #054071



j) (2) Washer, Nylon
0.281" x 1" x 0.06"
Part #054085

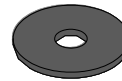

k) (4) Spacer Washer
7/16" x 1" x 1/4"
Part #054091



l) (2) Mud Flap Clip
Driver Side
Part # 769312

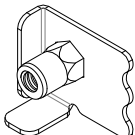

m) (2) Mud Flap Clip
Passenger Side
Part #769313

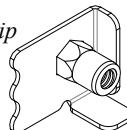

n) (2) Brace
Front
Part #771141

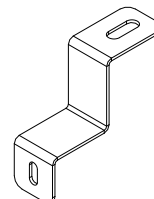

ASSEMBLY OF NYLON MUD FLAPS:

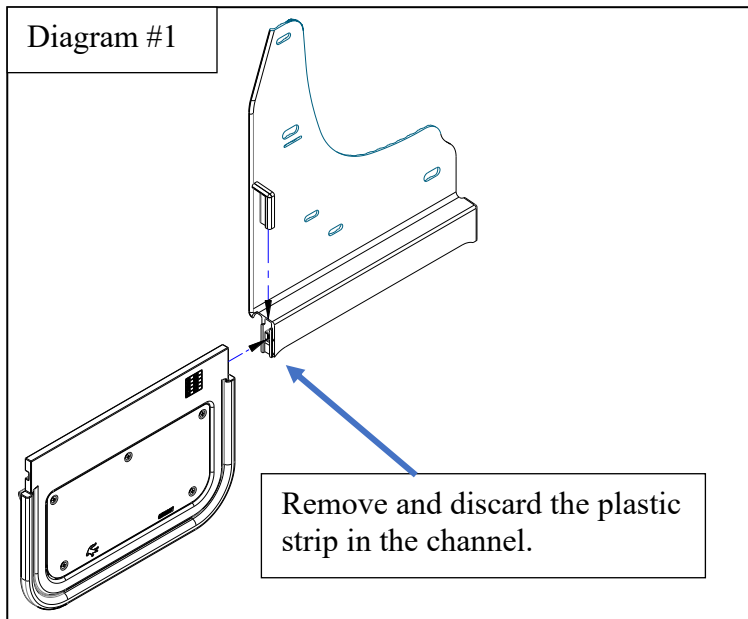

1. Remove locking caps from nylon upper mounts and set aside for reinstallation.
2. Remove and discard the plastic strip inside the track at the bottom of the nylon upper mount.
3. Slide rubber guide into track of nylon upper mount.
4. Reinstall locking cap(s) on bottom of nylon upper mount. Note: To fully lock this cap into place, you should hear two clicks. When the cap is fully locked, it will be even with the offset part of the upper mount.
5. Repeat Procedure for second mud flap.

MUD FLAPS:

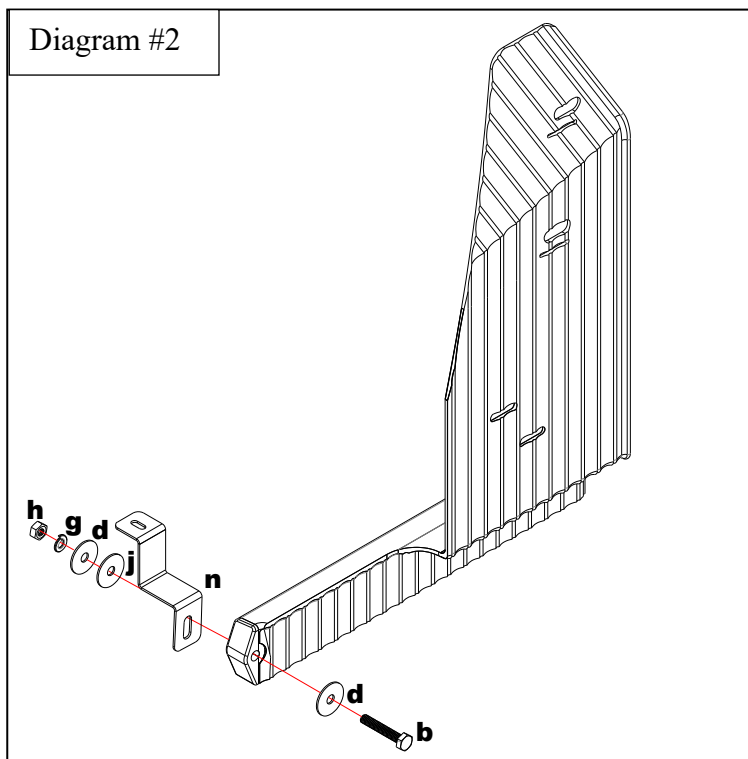

1. Before you install your Mud Flap Set, see the diagram and parts list for all necessary parts. Start on the driver's side.
2. Install bracket (n) to innermost mud flap hole using a cap screw (b), and flat washer (d), and secure using a flat washer (d), nylon washer (j), lock washer (g), and hex nut (h).

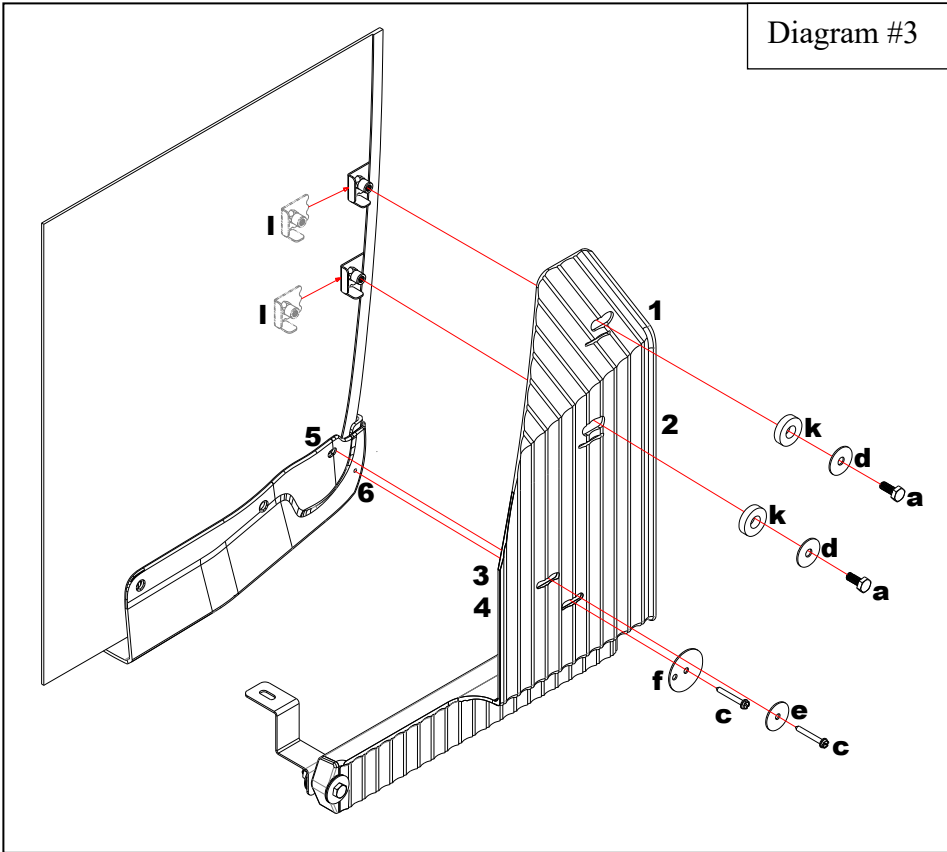

3. Loosely install mud flap clips (l) to mud flap holes #1 & #2 using a cap screw (a), flat washer (d), and spacer washer (k).
4. Remove factory screw from hole #5.
5. Loosely install mud flap hole #3 to factory hole #5 using screw (c) and flat washer (e).
6. Slide mount clips (l) behind fender lip.
7. Install mud flap hole #4 to factory hole #6 using screw (c) and offset washer (f)

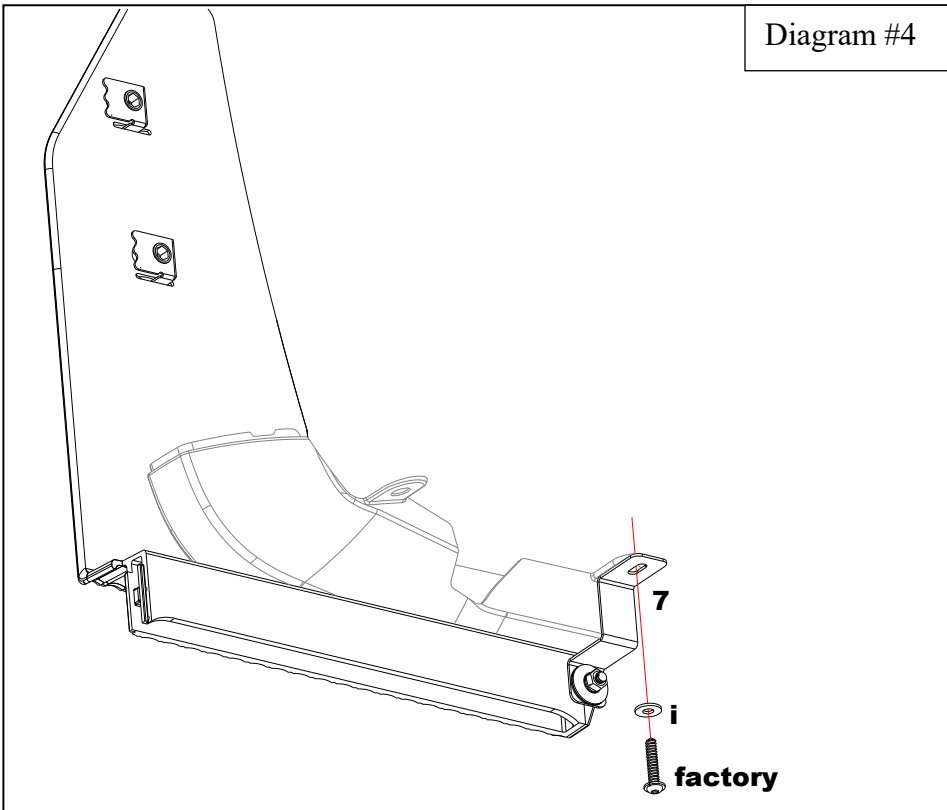

8. Install bracket hole #7 to finishing cap hole using factory screw and nylon washer (i)
9. Using a bubble level or other levelling tool, ensure that the mud flap is level. Tighten fasteners.
10. Once everything is secure, slowly install screw (c) and offset washer (f) into hole #4 and into the factory cap. (See Diagram #3)
Be careful not to overtighten.
11. Repeat procedure for passenger side.



24-C Silverado HD ZR2
Nylon Mud Flap Set, 1.5" Offset, Rear
Mounting Diagram & Instructions
Kit# GCN213R

IMPORTANT:

Manufacturer is not responsible for negligent use of vehicle with mud flaps installed, including over-tightening of screws and bolts causing damage to vehicle or mud flaps.



TOOLS REQUIRED-

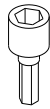

1/4" Socket Driver

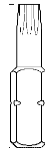

T15 Torx Bit

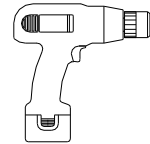

Electric or Rechargeable Drill

FLAPS

(1) Flap Assy Upper Rear, DS
 Part #770431

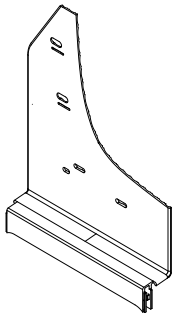

(1) Flap Assy Upper Rear, PS
 Part #770432

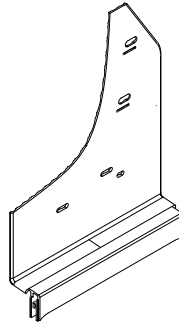

(2) Rubber Flap Universal
 12" x 10-3/4"

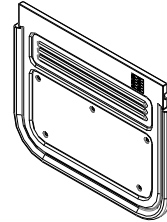

Please note: There will be a plastic piece in the upper mount channel. Please remove and discard.

(2) Nylon Cap Driver Side
 Part #080642
 (Assembled on Upper Mount)

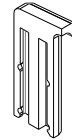

(2) Nylon Cap Passenger Side
 Part #080643
 (Assembled on Upper Mount)

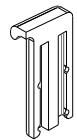

PARTS BAG # 770425

a) (4) Capscrew
 1/4"-20UNC x 5/8" SS, ox.
 Part #014071



b) (6) Screw, Sheet Metal, Blk Ox.
 1/4" Hex Washer Head, #8-18x1.5"
 Part # 016063



c) (4) Washer, Flat
 0.281" x 1", 18g, SS, oxid.
 Part #018069

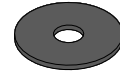

d) (6) Offset Washer
 0.203" x 1"
 Part #018080



e) (4) Spacer Washer
 7/16" x 1" x 1/4"
 Part #054091

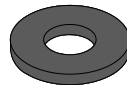

f) (2) Mud Flap Clip
 Driver Side
 Part # 769312

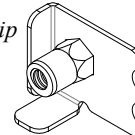

g) (2) Mud Flap Clip
 Passenger Side
 Part #769313

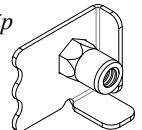

ASSEMBLY OF NYLON MUD FLAPS:

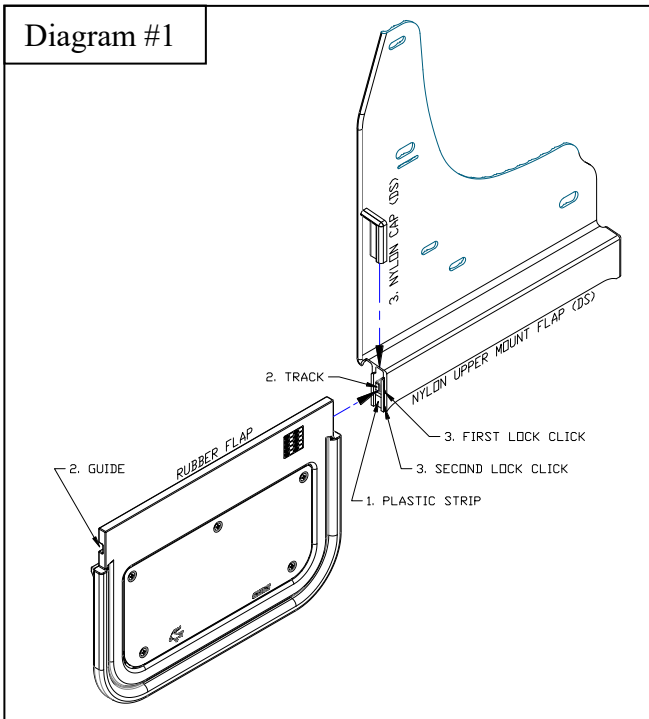

1. Remove locking caps from nylon upper mounts and set aside for reinstallation.
2. Remove and discard the plastic strip inside the track at the bottom of the nylon upper mount. (See Diagram #1).
3. Slide rubber guide into track of nylon upper mount.
4. Reinstall locking cap(s) on bottom of nylon upper mount.
Note: To fully lock this cap into place, you should hear two clicks. When the cap is fully locked, it will be even with the offset part of the upper mount. (See Diagram #1).
5. Repeat Procedure for second mud flap.

MUD FLAPS: (See Diagram #2)

1. Before you install your Mud Flap Set, see the diagram and parts list for all necessary parts. Start on the driver's side.
2. Install mount clips (f) on mud flap holes #1 & #2 using a cap screw (a), flat washer (c), and spacer washer (e)
3. Remove factory screws from holes #6 & #7.
4. Loosely install mud flap hole #3 to factory hole #6 using a screw (b) and offset washer (d).
5. Slide mount clips (f) behind fender lip.
6. Loosely install mud flap hole #5 to factory hole #7 using a screw (b) and offset washer (d).
7. Using a bubble level or other levelling tool, ensure that the mud flap is level. Tighten fasteners.
8. Once everything is secure, slowly install screw (b) and offset washer (d) through hole #4 into the plastic factory cap. **Be careful not to overtighten.**
8. Repeat procedure for passenger side.

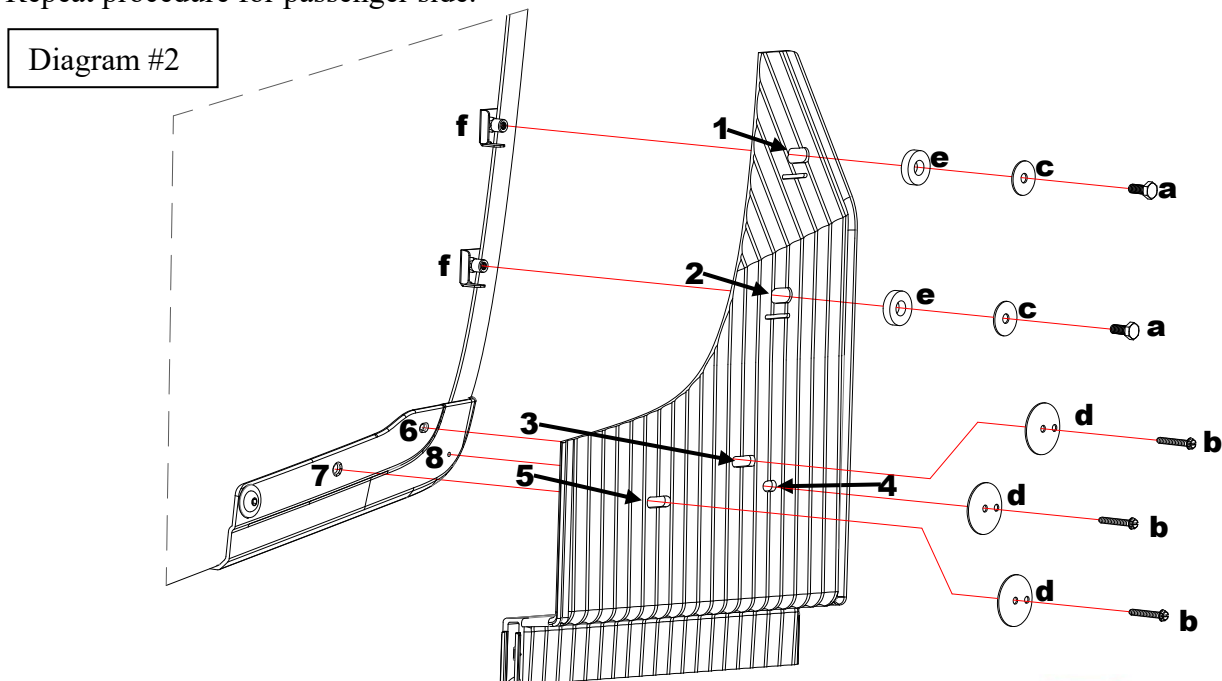

Please check out our YouTube channel to see an install video for this application.

