

IMPORTANT:

Manufacturer is not responsible for negligent use of vehicle with mud flaps installed, including over-tightening of screws and bolts causing damage to vehicle or mud flaps.

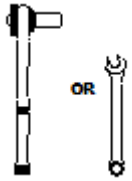

TOOLS REQUIRED-



1/2" Open Wrench or
Socket Wrench

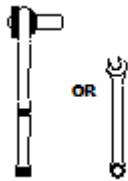

1/4" Open Wrench or
Socket Wrench

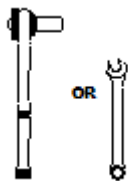

7/16" Open Wrench or
Socket Wrench



T15 Torx
Bit

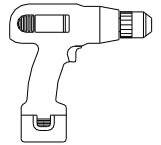

Electric or Rechargeable
Drill

FLAPS

(1) Upper Mount
Front, DS
Part #771214

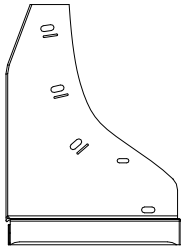

(1) Upper Mount
Front, PS
Part #771215

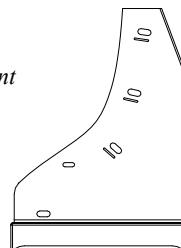

(2) Rubber Flap
Universal
12" x 8-3/4"

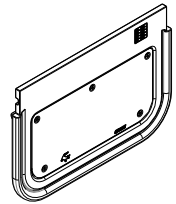

(1) Nylon Cap
Driver Side
Part #080642
(Assembled on Upper Mount)

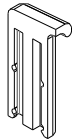

(1) Nylon Cap
Passenger Side
Part #080643
(Assembled on Upper Mount)

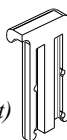

(1) Bracket
Driver Side
Part #771218

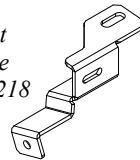

(1) Bracket
Passenger Side
Part #771219

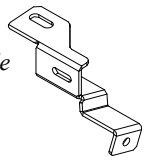

PARTS BAG # 771220

a) (8) Capscrew
1/4"-20 x 1" SS, ox.
Part #014073

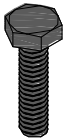

b) (2) Screw, Sheet Metal, Blk Ox.
1/4" Hex Washer Head, #8-18x1.25"
Part # 016061



c) (2) Spacer Washer, HDPE
5/16" x 1" x 1/4"
Part #018036

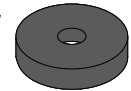

d) (2) Washer, Flat
0.281" x 1", SS, oxid
Part #018069

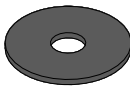

e) (2) Washer, Flat
0.203" x 1", SS, oxid.
Part #018070

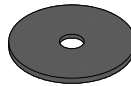

f) (2) Serrated Flange Nut
1/4-20, Stainless
Part #025034



g) (6) Washer, Nylon
0.265" x 0.625"
Part #054071



h) (6) Universal U-clamp
1.5" x 3" Anodized
Part #767416

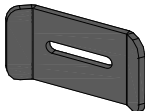

i) (3) Mud Flap Clip
Driver Side
Part # 769312

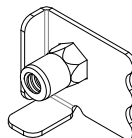

j) (3) Mud Flap Clip
Passenger Side
Part #769313

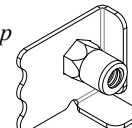

MUD FLAPS:

Before you install your Mud Flap Set, see the parts list for all necessary parts. Start on the driver's side.

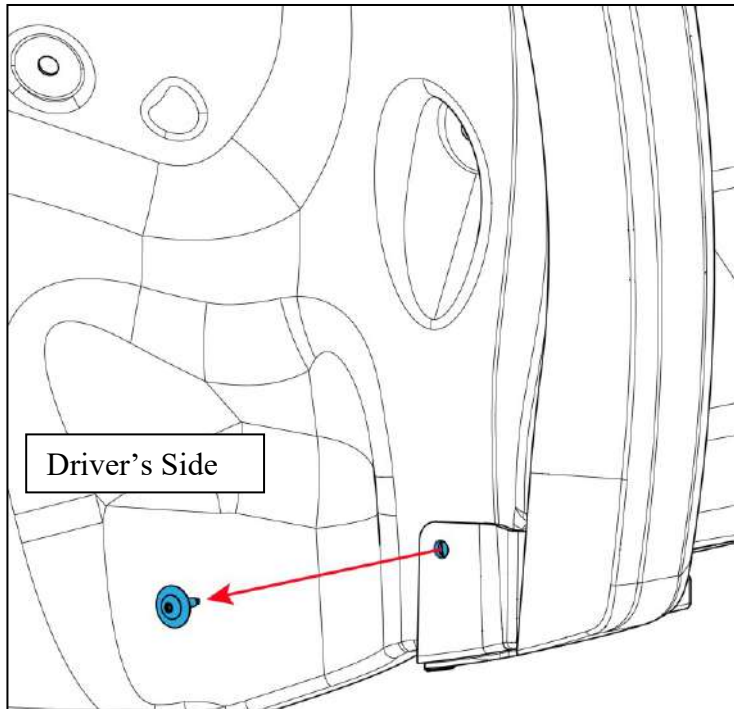

1-1 Remove the factory screws from the wheel well, as shown.

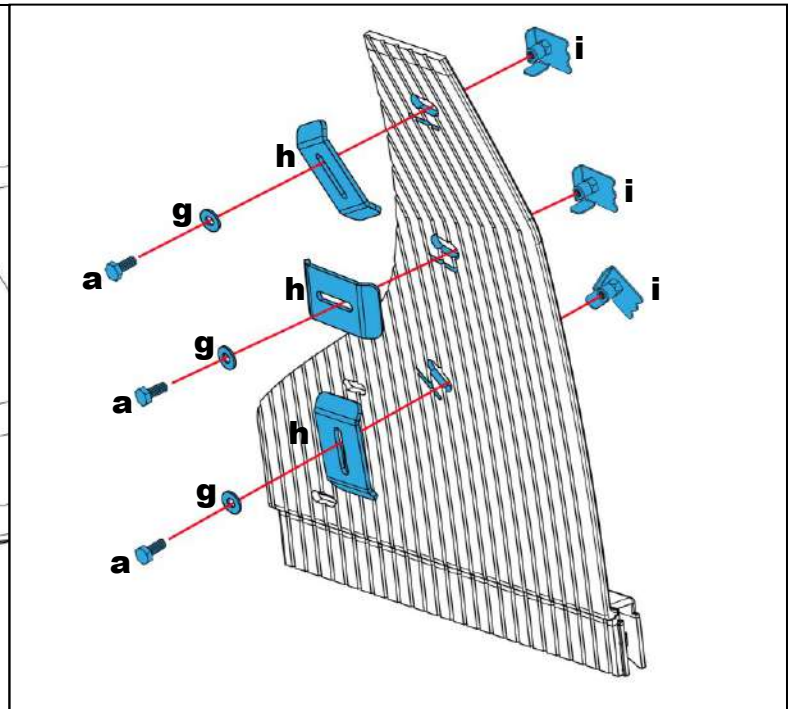

2-1 Loosely install mount clips as shown.

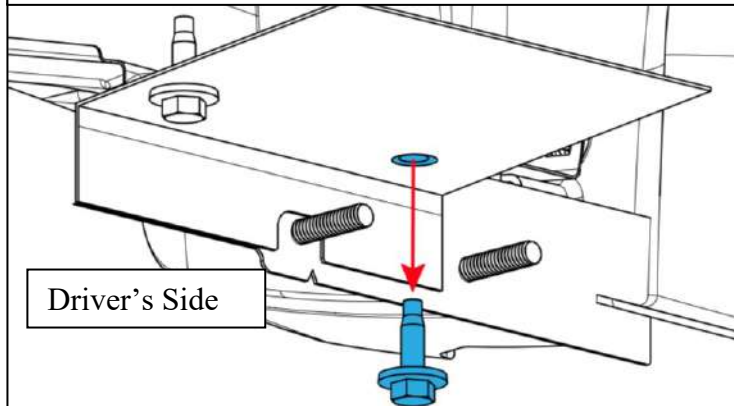

3-1 Remove the factory screws from the underside of the body, as shown.

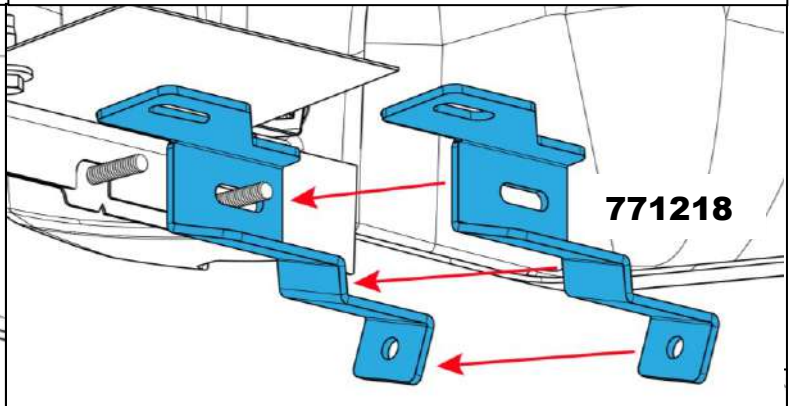

3-2 Install bracket as shown.

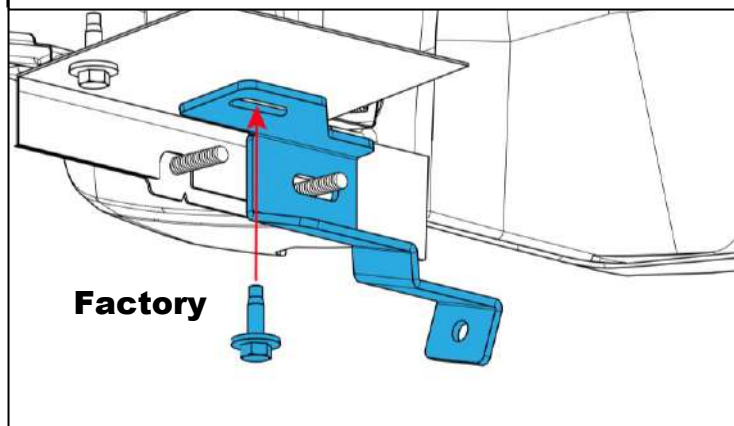

3-3 Reinstall factory screw as shown.

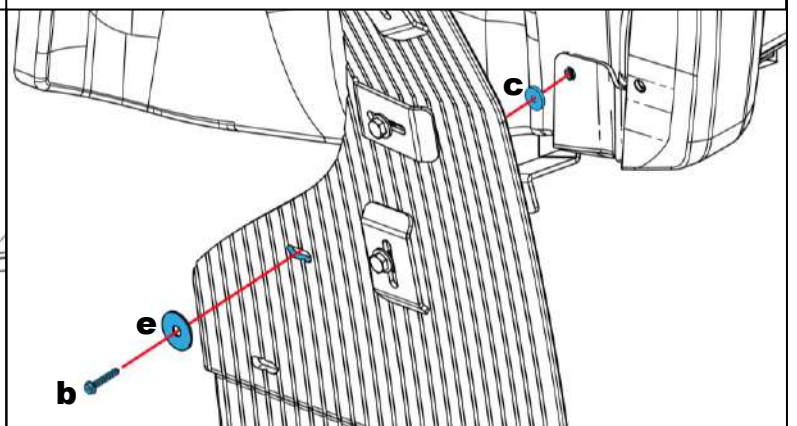

4-1. Install mud flap to factory hole as shown.

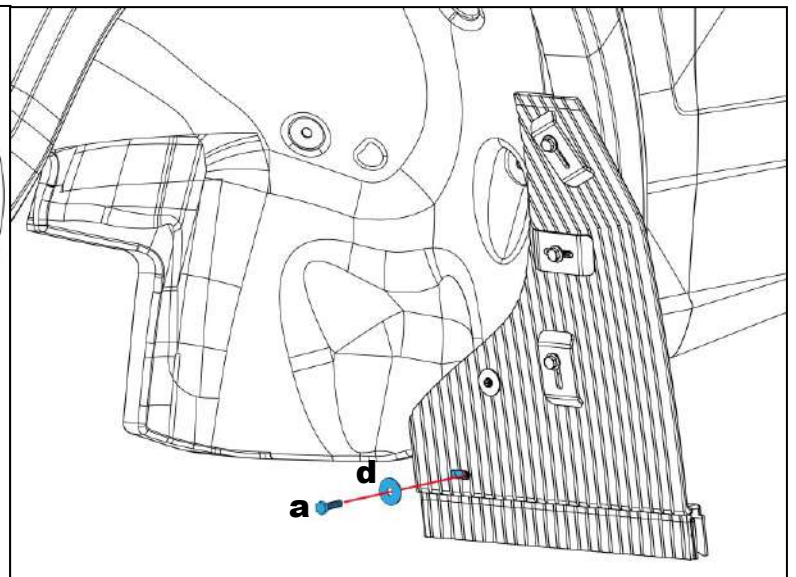
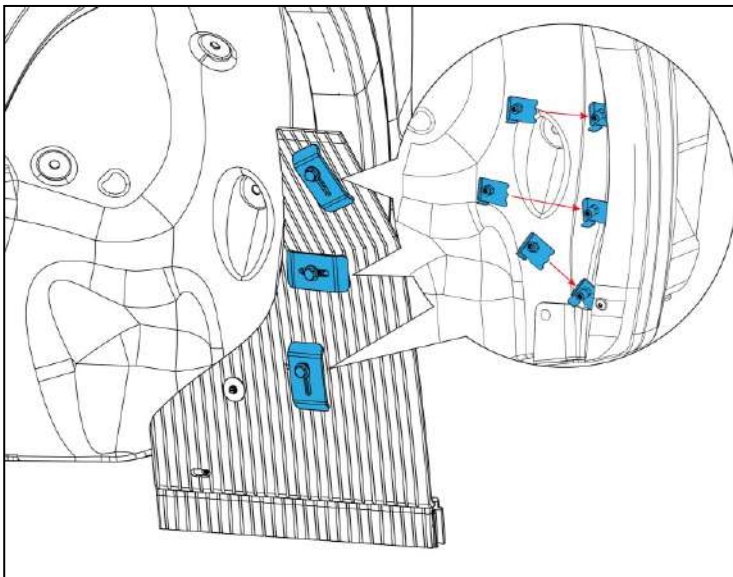

5-1 Slide mount clips behind the fender lip and loosely secure

6-1 Install hardware as shown.

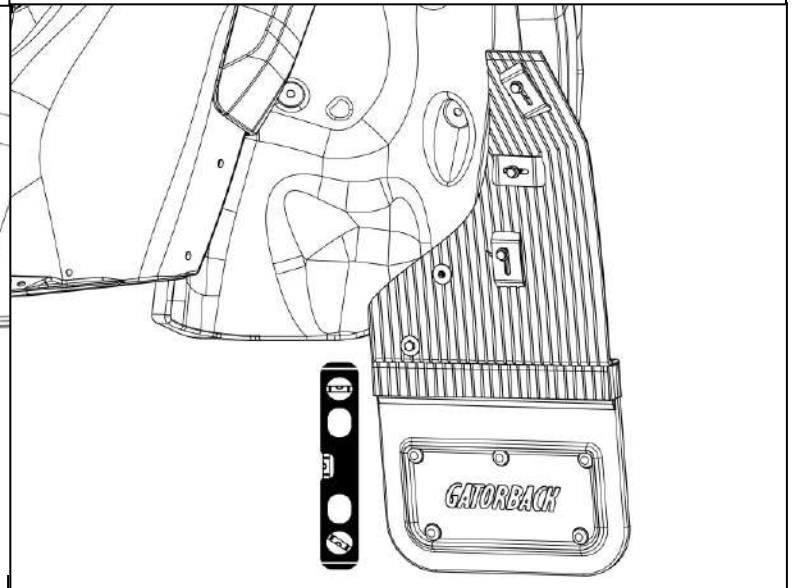
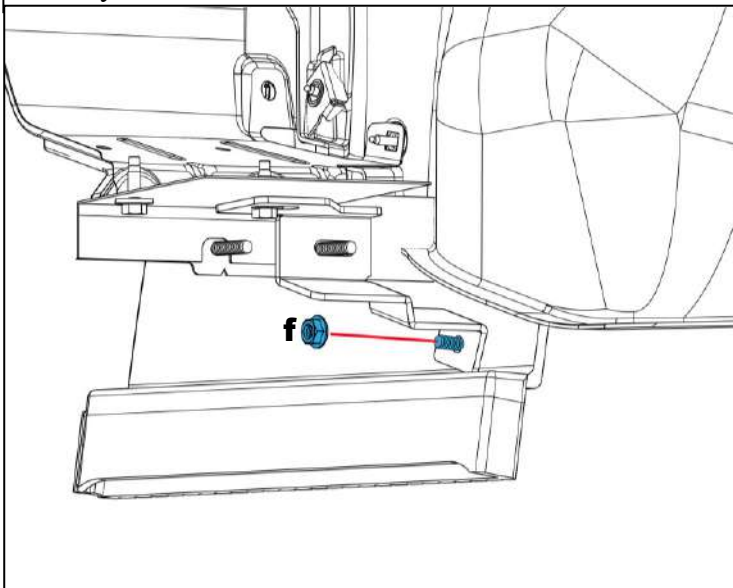

6-2 Secure hardware installed in step 6-1 as shown.

7-1 Using a bubble level or other levelling tool, ensure that the mud flap is level. Tighten fasteners. Be sure to align the u-clamps so they are adding pressure to hold the mud flap tight against the wheel well.

Repeat procedure for passenger side.

ASSEMBLY OF NYLON MUD FLAPS:

1. Remove locking caps from nylon upper mounts and set aside for reinstallation.
2. Remove and discard the plastic strip inside the track at the bottom of the nylon upper mount.
3. Slide rubber guide into track of nylon upper mount.
4. Reinstall locking cap(s) on bottom of nylon upper mount.
Note: To fully lock this cap into place, you should hear two clicks. When the cap is fully locked, it will be even with the offset part of the upper mount.
5. Repeat Procedure for second mud flap.

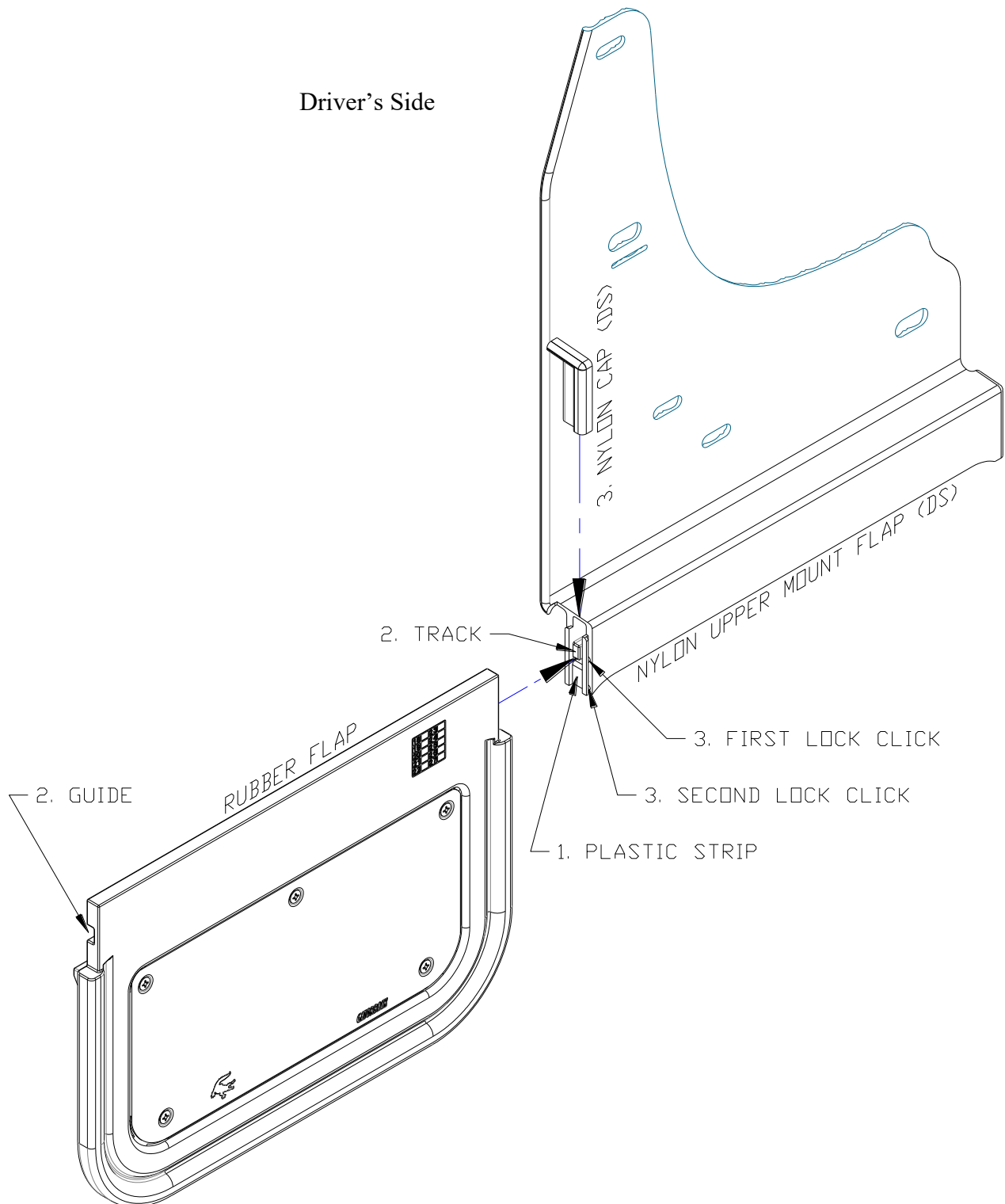

Please check out our YouTube channel to see an install video for this application.



IMPORTANT:

Manufacturer is not responsible for negligent use of vehicle with mud flaps installed, including over-tightening of screws and bolts causing damage to vehicle or mud flaps.



TOOLS REQUIRED-

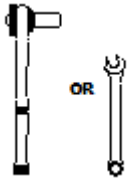

1/4" Open Wrench or
Socket Wrench

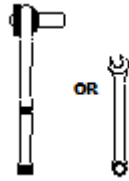

7/16" Open Wrench or
Socket Wrench



T15 Torx
Bit

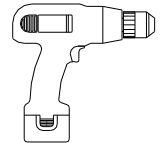

Electric or Rechargeable
Drill

FLAPS

(1) Upper Mount
Rear, DS
Part #771214

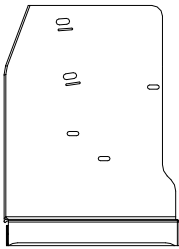

(1) Upper Mount
Rear, PS
Part #771215

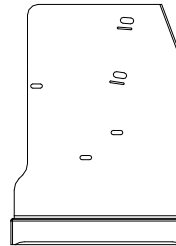

(2) Rubber Flap
Universal
12" x 10-3/4"

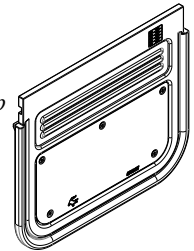

(1) Nylon Cap
Driver Side
Part #080642
(Assembled on Upper Mount)

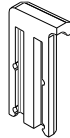

(1) Nylon Cap
Passenger Side
Part #080643
(Assembled on Upper Mount)

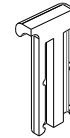

PARTS BAG # 771221

a) (4) Capscrew
1/4"-20 x 1" SS, oxidized
Part #014073



b) (2) Screw, Sheet Metal, Blk Ox.
1/4" Hex Washer Head, #8-18x1"
Part # 016055



c) (4) Screw, Sheet Metal, Blk Ox.
1/4" Hex Washer Head, #8-18x1.25"
Part # 016061



d) (8) Washer, Flat
0.203" x 1", SS, ox..
Part #018070

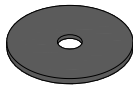

e) (2) Washer, Offset
0.203" x 1.5" SS Ox.
Part #018080

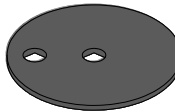

f) (2) Spacer, Nylon
1/4" x 1/2" x 1/2"
Part #054063



g) (4) Washer, Nylon
0.265" x 0.625"
Part #054071



h) (2) Washer, Nylon
0.203" x 0.885"
Part #054080

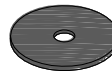

i) (6) Universal U-clamp
1.5" x 3" Anodized
Part #767416

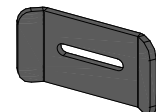

j) (2) Mud Flap Clip
Driver Side
Part # 769308

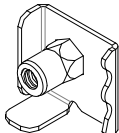

k) (2) Mud Flap Clip
Passenger Side
Part #769309

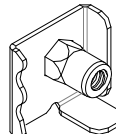

MUD FLAPS:

Before you install your Mud Flap Set, see the parts list for all necessary parts. Start on the driver's side.

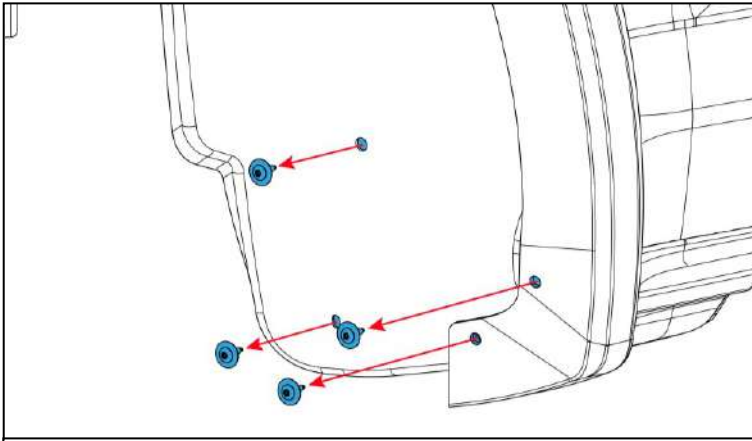

1-1 Remove the factory screws from the wheel well as shown.

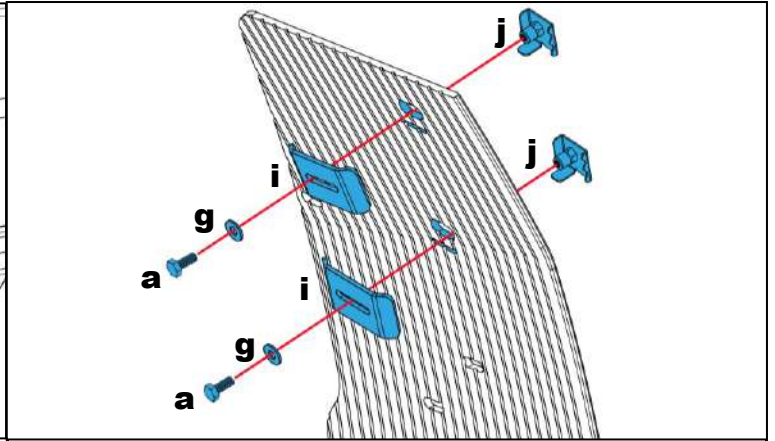

2-1 Loosely install mount clips as shown.

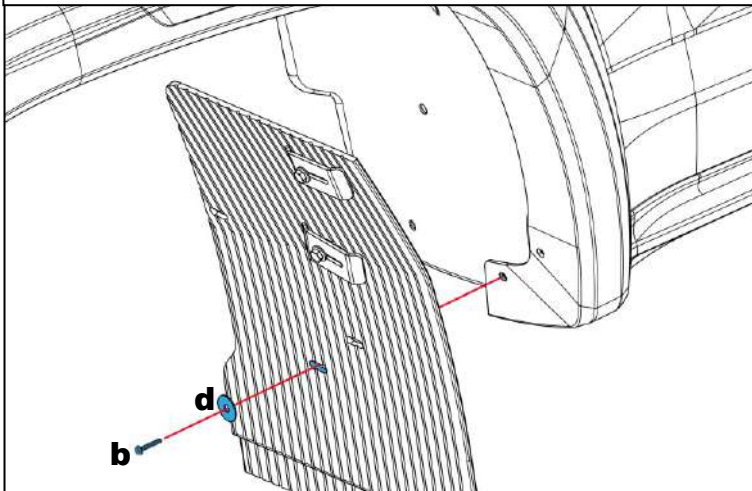

3-1 Install mud flap to factory hole as shown.

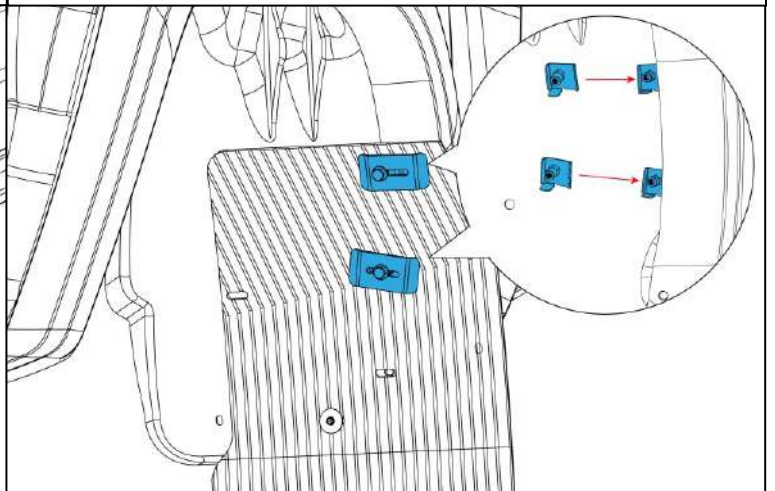

4-1 Slide mount clips behind the fender lip and loosely secure.

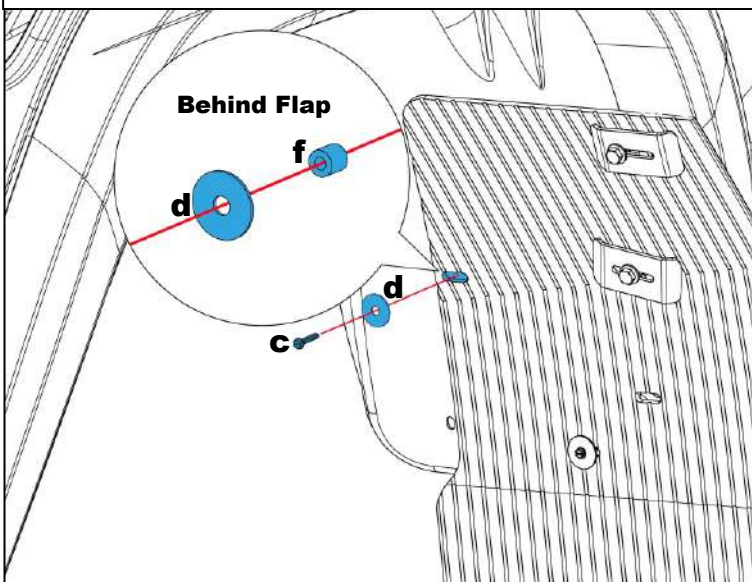

5-1 Install mud flap to factory hole as shown. Note: one flat washer and the nylon spacer sit between the mud flap and the wheel well.

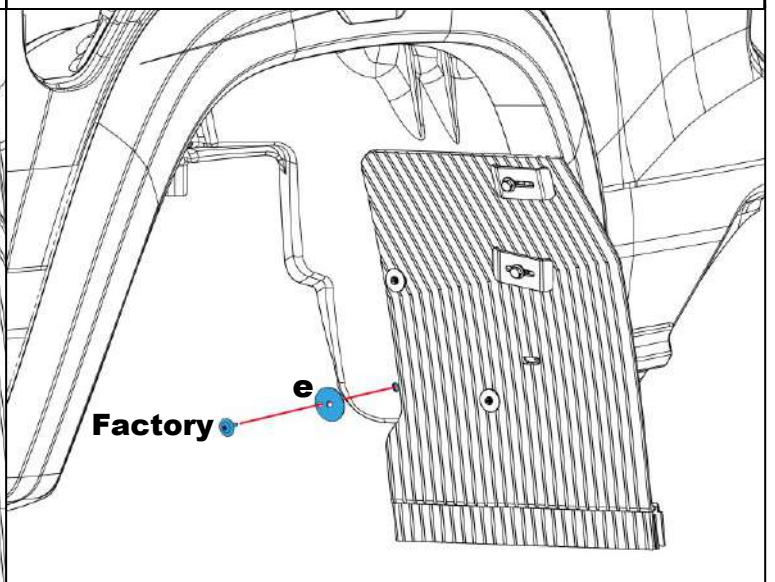

6-1 Reinstall factory screw with offset washer. Ensure the screw is placed through the offset hole and the large portion of the washer is putting pressure on the flap as shown.

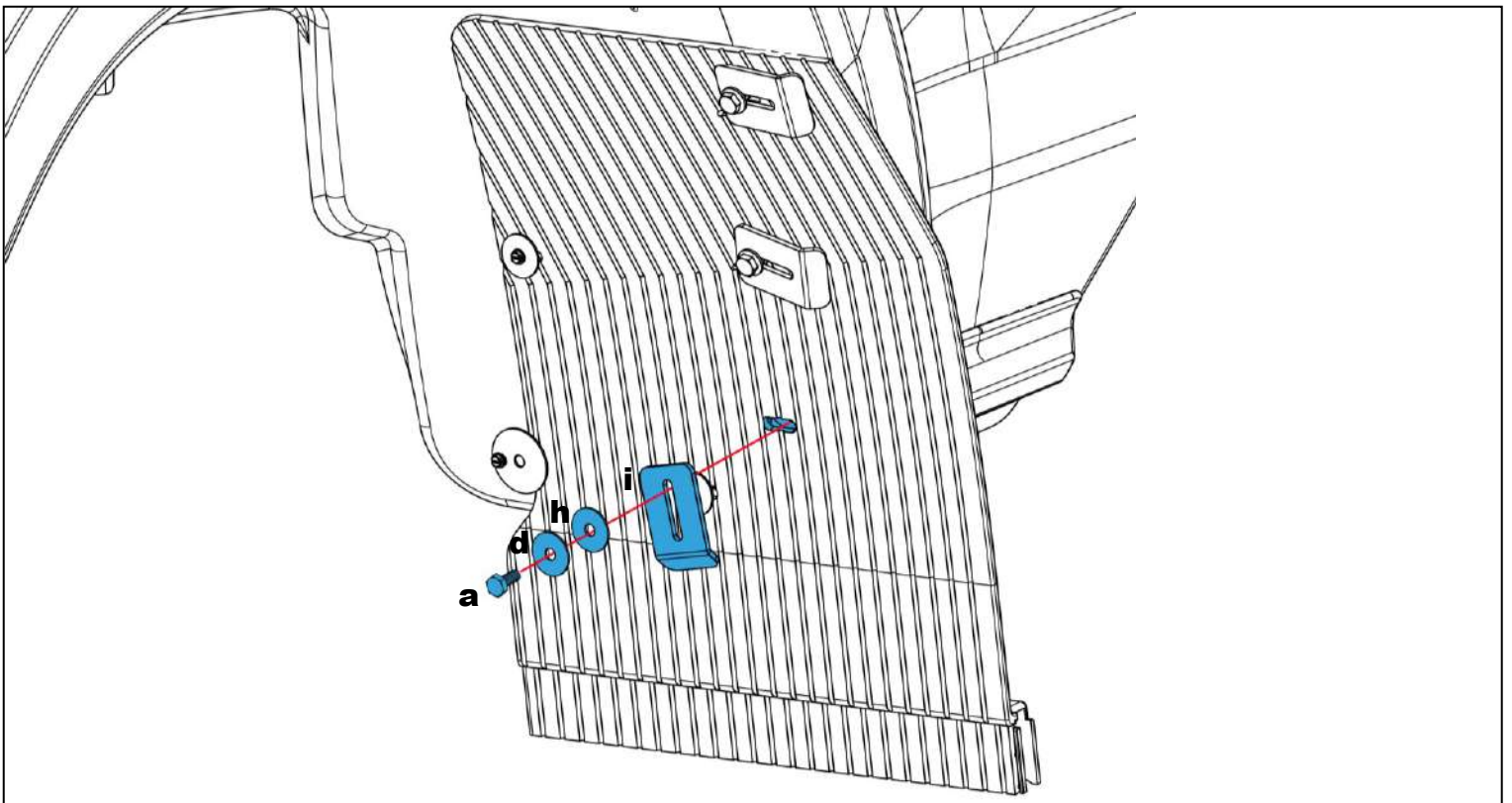

7-1 Install mud flap to factory hole as shown.

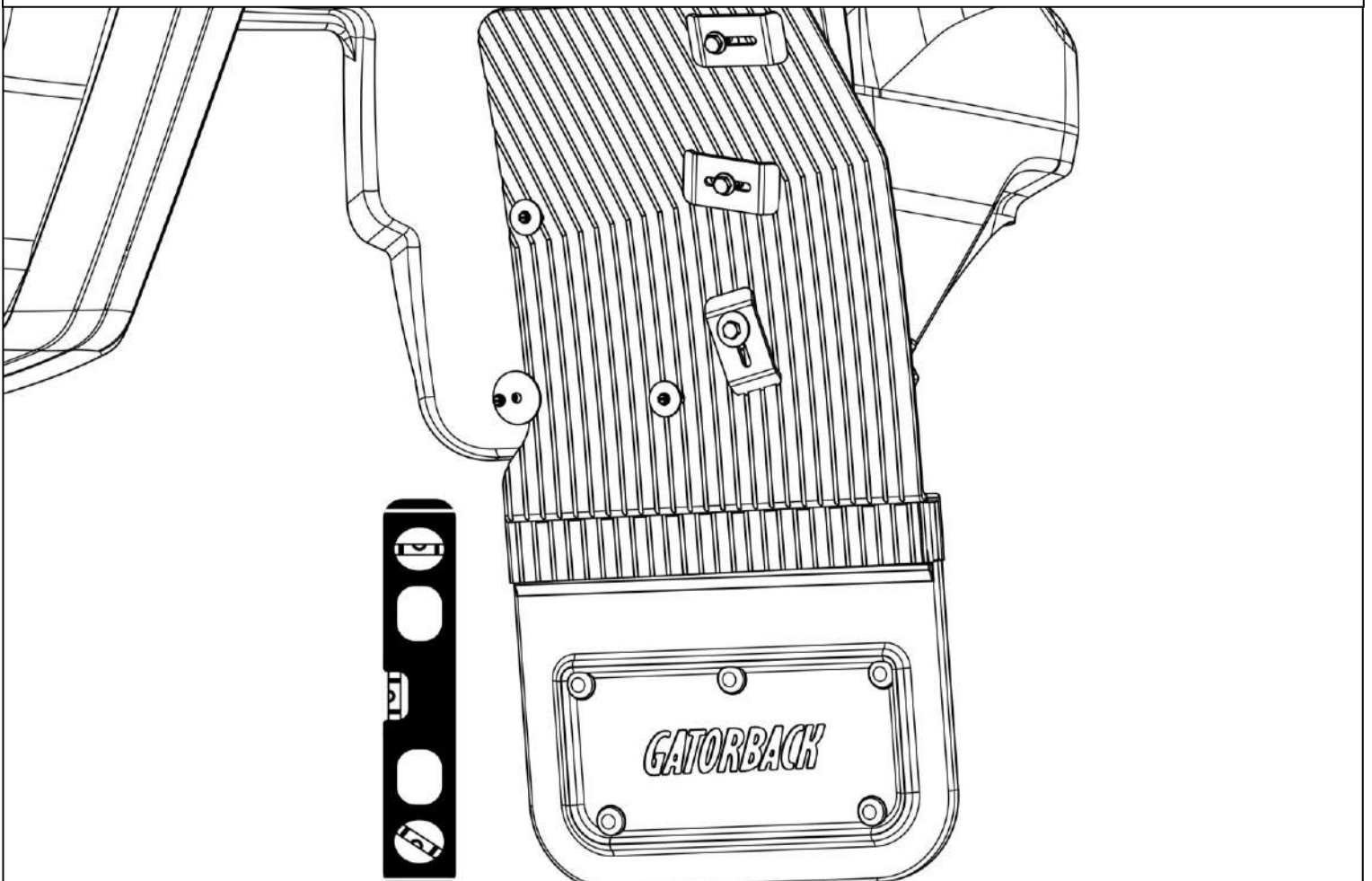

8-1 Using a bubble level or other levelling tool, ensure that the mud flap is level. Tighten fasteners. Be sure to align the u-clamps so they are adding pressure to hold the mud flap tight against the wheel well.

Repeat procedure for passenger side.

ASSEMBLY OF NYLON MUD FLAPS:

1. Remove locking caps from nylon upper mounts and set aside for reinstallation.
2. Remove and discard the plastic strip inside the track at the bottom of the nylon upper mount.
3. Slide rubber guide into track of nylon upper mount.
4. Reinstall locking cap(s) on bottom of nylon upper mount. **Note: To fully lock this cap into place, you should hear two clicks.** When the cap is fully locked, it will be even with the offset part of the upper mount.
5. Repeat Procedure for second mud flap.

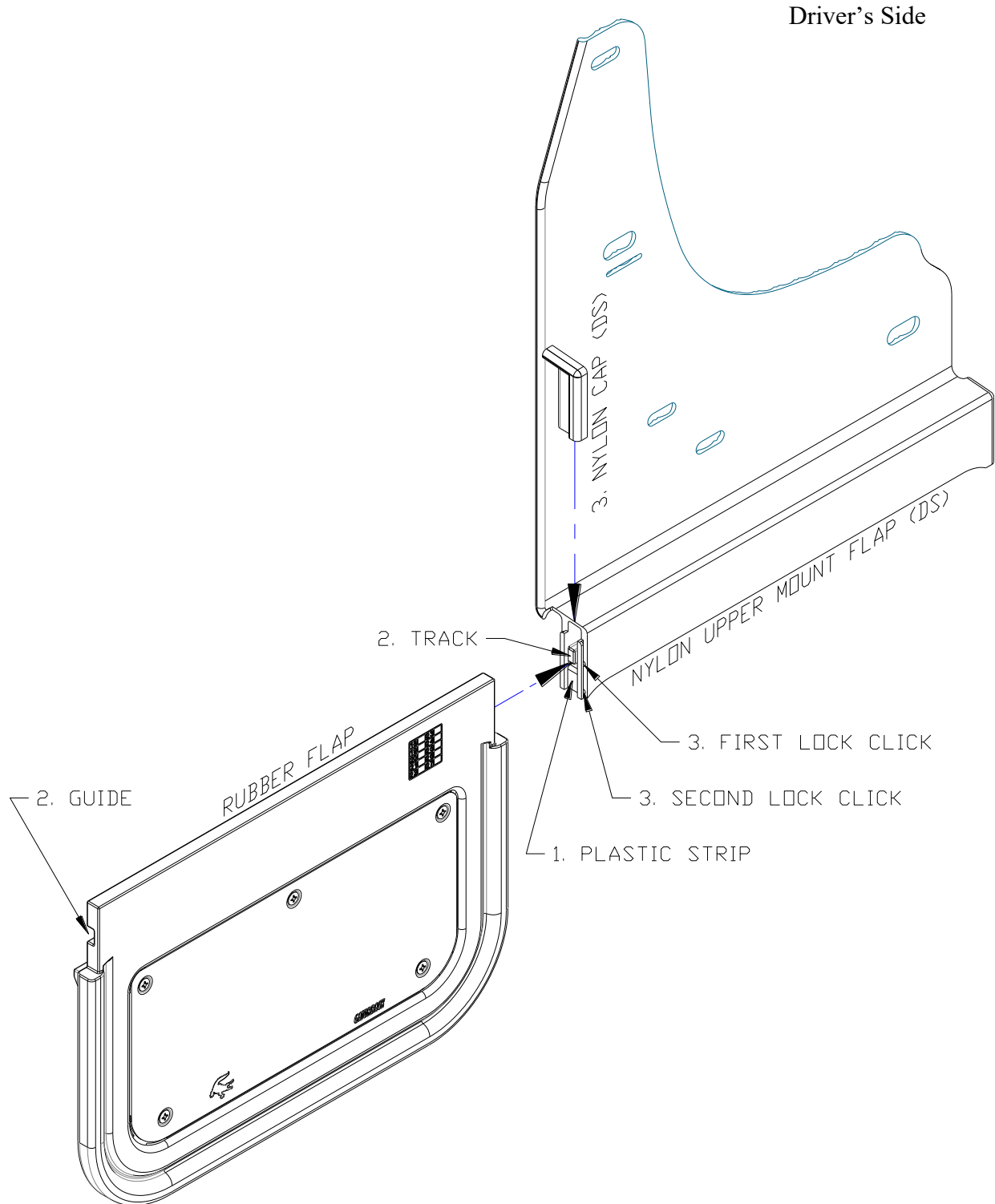

Please check out our YouTube channel to see an install video for this application.

