

IMPORTANT:

The manufacturer is not responsible for negligent use of vehicle with mud flaps installed, including over-tightening of screws and bolts causing damage to vehicle or mud flaps.

Before you install your Mud Flap Set, see the diagram and parts list for all necessary parts.

All hardware should be loosely installed until all mounting points have been installed and flap has been levelled. It is suggested that final tightening of hardware be done with hand tools to avoid over-tightening.

TOOLS REQUIRED:

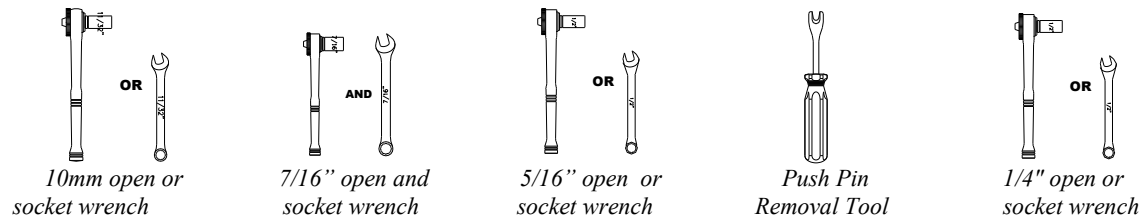

FLAPS & BRACKETS

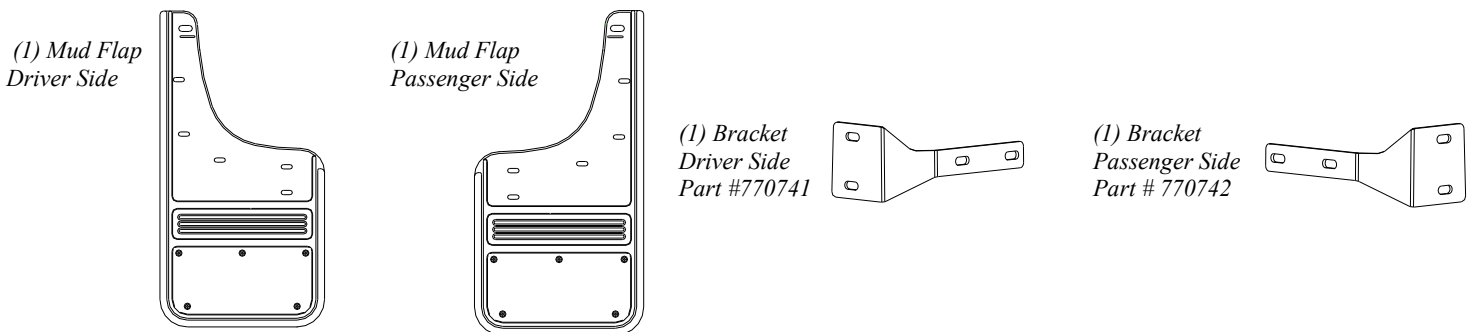

PARTS BAG #770760

a) (2) Capscrew, SS, Blk Ox.
1/4"-20UNC x 3/8"
Part # 014069



b) (2) Capscrew, SS, Blk Ox.
1/4" - 20UNC x 3/4"
Part # 014070



c) (4) Capscrew, SS, Blk Ox.
1/4"-20UNC x 1"
Part #014073

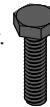

d) (4) Sht Mtl Screw
8-18 x 1.25" SS Blk Ox
Part #016061

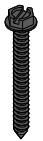

e) (4) Washer, Flat
0.281" x 1", SS
Part #018068

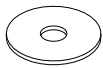

f) (6) Washer, Flat
0.281" x 1" SS Blk Ox.
Part # 018069

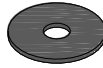

g) (4) Washer, Flat
0.203" x 1" SS Blk Ox
Part # 018070

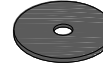

h) (4) Washer, Lock
1/4" Helicoil, SS
Part # 024000



i) (4) Hex Nut
1/4"-20, SS
Part # 025000



j) (4) Flange Nut,
M6, Serrated
Part #025025



k) (2) Spring Nut
1/4"-20UNC, 0.54", SS
Part #028010



l) (4) Washer, Nylon
0.318" x 1"
Part #054061

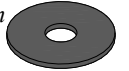

m) (2) Washer, Nylon
0.38"x0.625" Blk
Part #054071



n) (2) Washer, Nylon
0.281" x 1" Blk
Part # 054084



o) (2) J-Clamp
1.5" x 2.5"
Part #767417

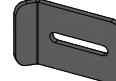

p) (1) Mount Clip
DS
Part # 769308

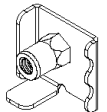

q) (1) Mount Clip
PS
Part #769309

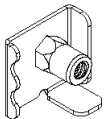

r) (1) Protective Tape
Universal, 2 pc
Part #770681

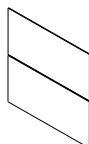

Installation

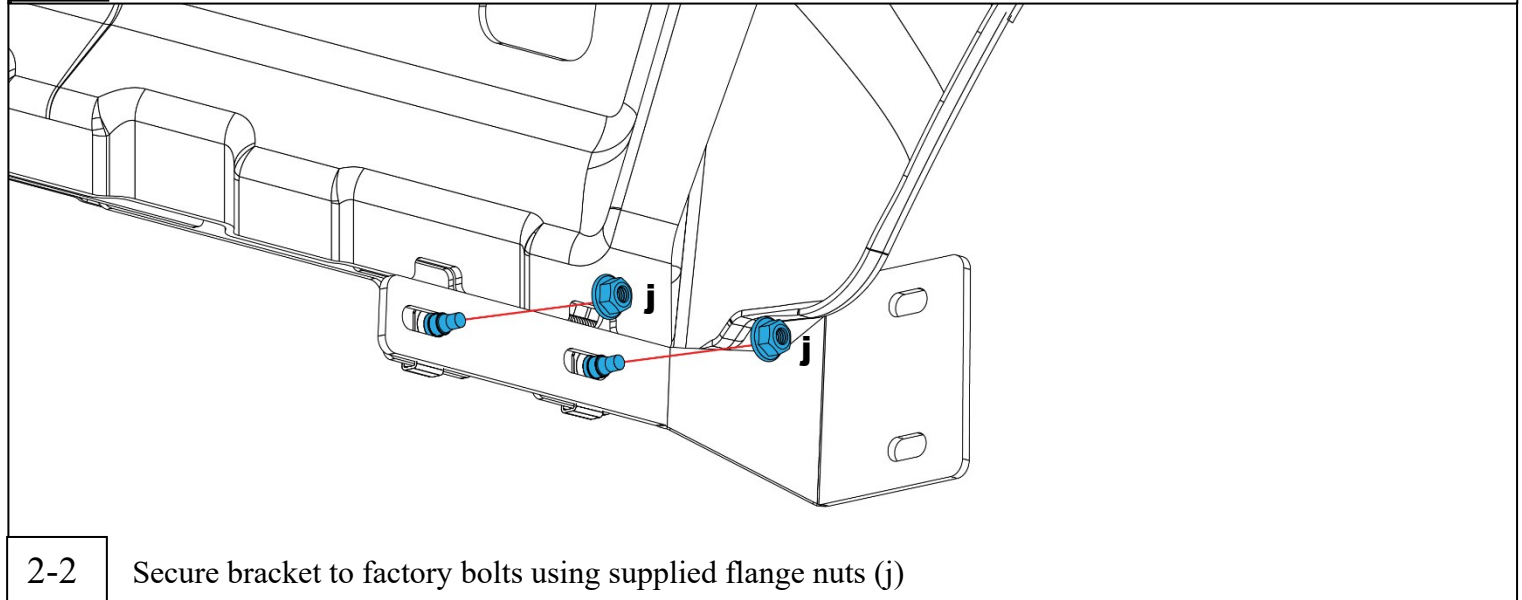
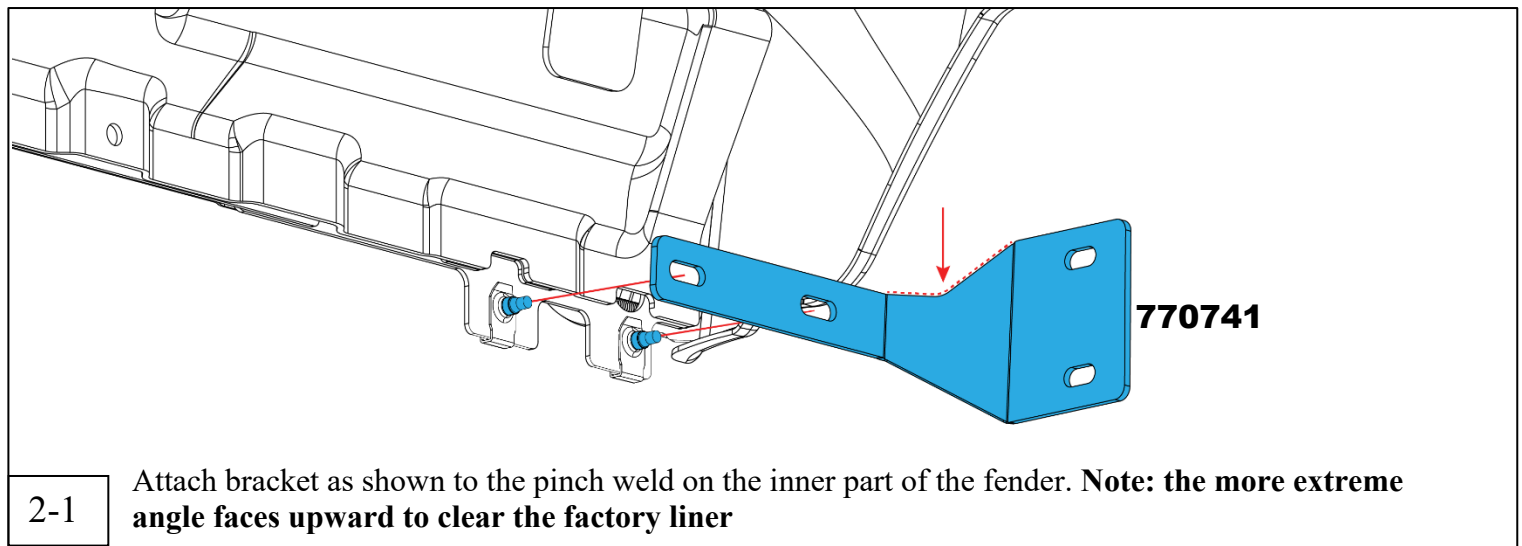
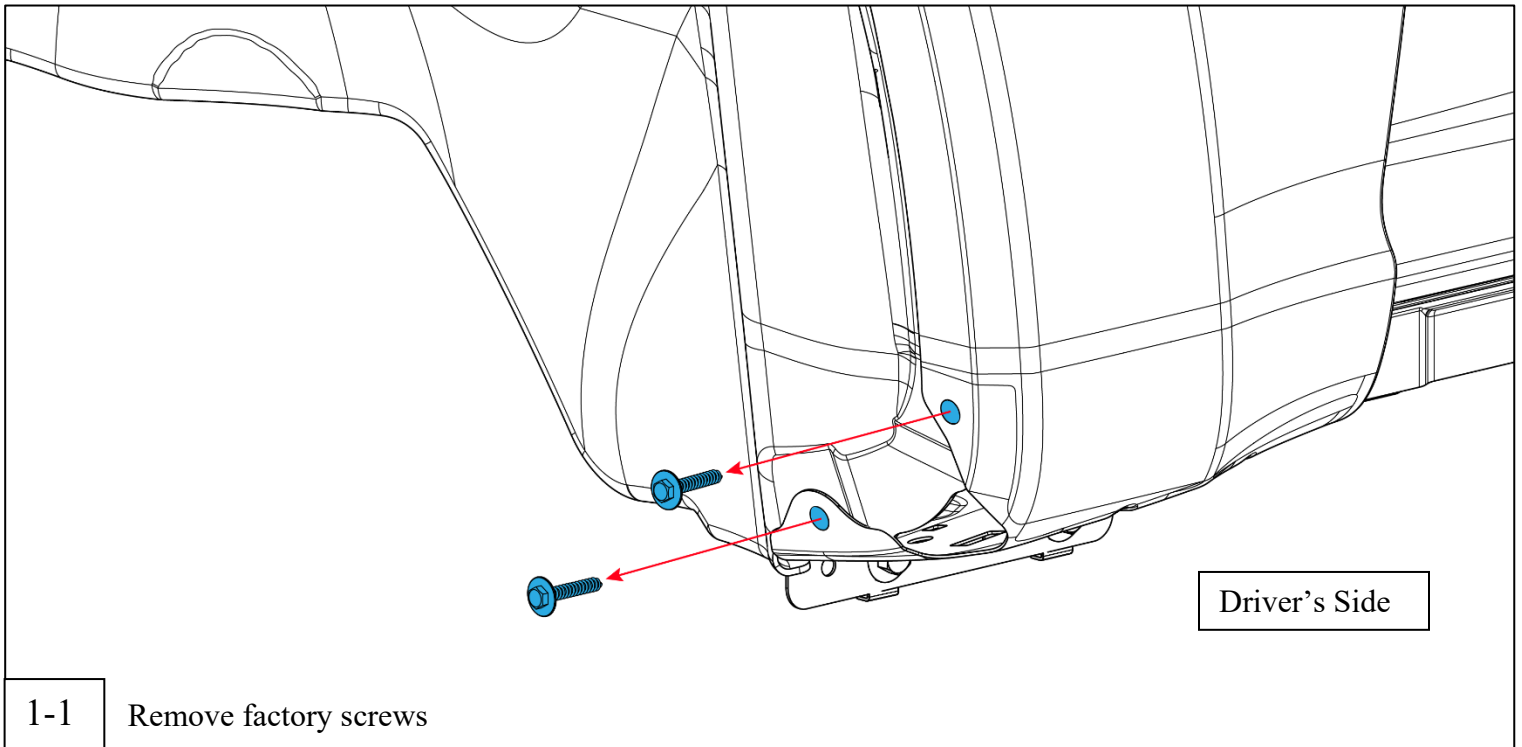

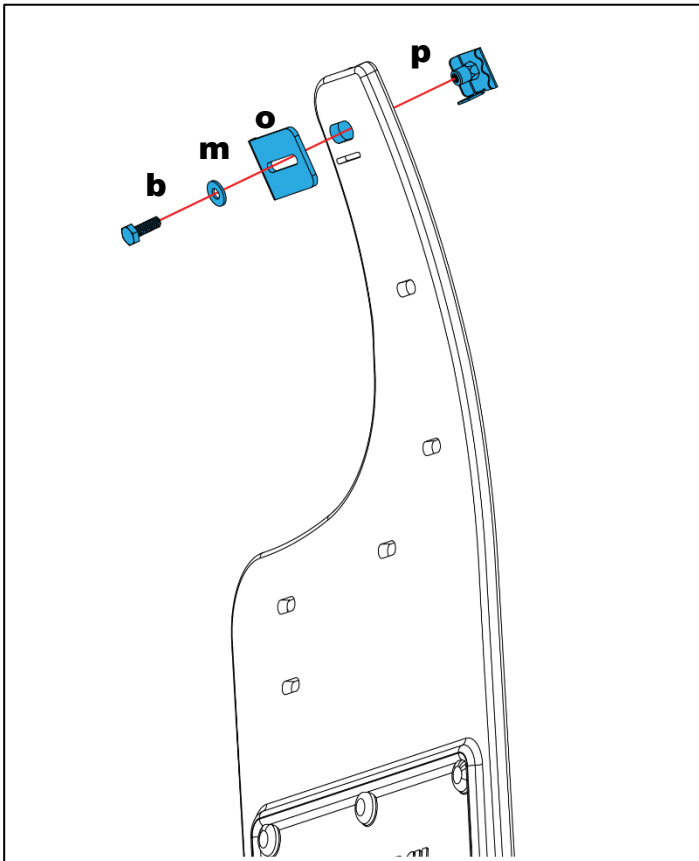

3-1

Loosely install mount clip to top mud flap hole. Do not install on the fender lip at this time.

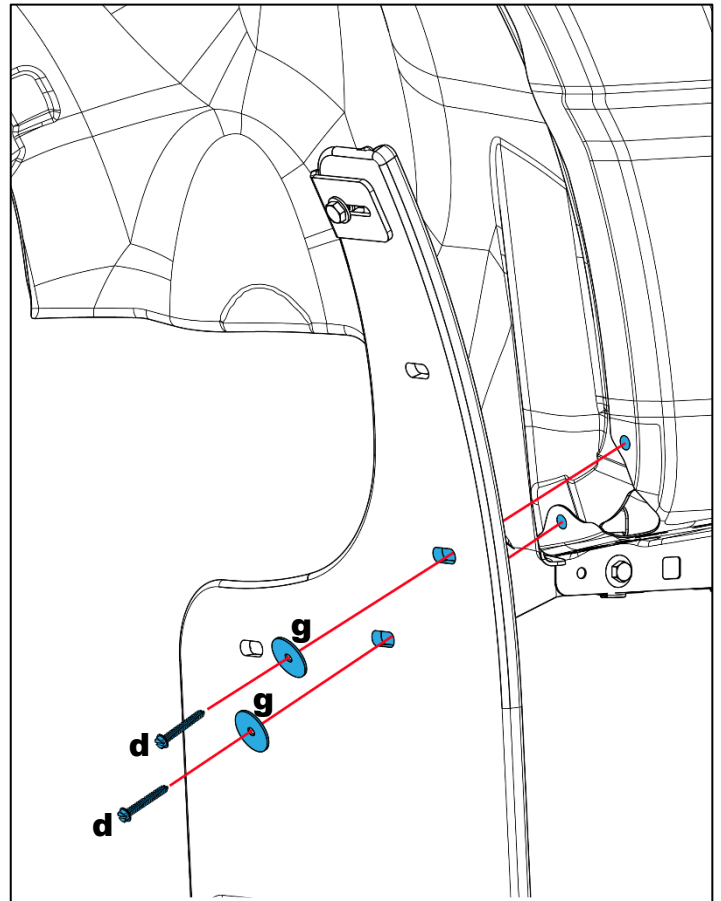

4-1

Install these two mud flap holes to the factory holes as shown

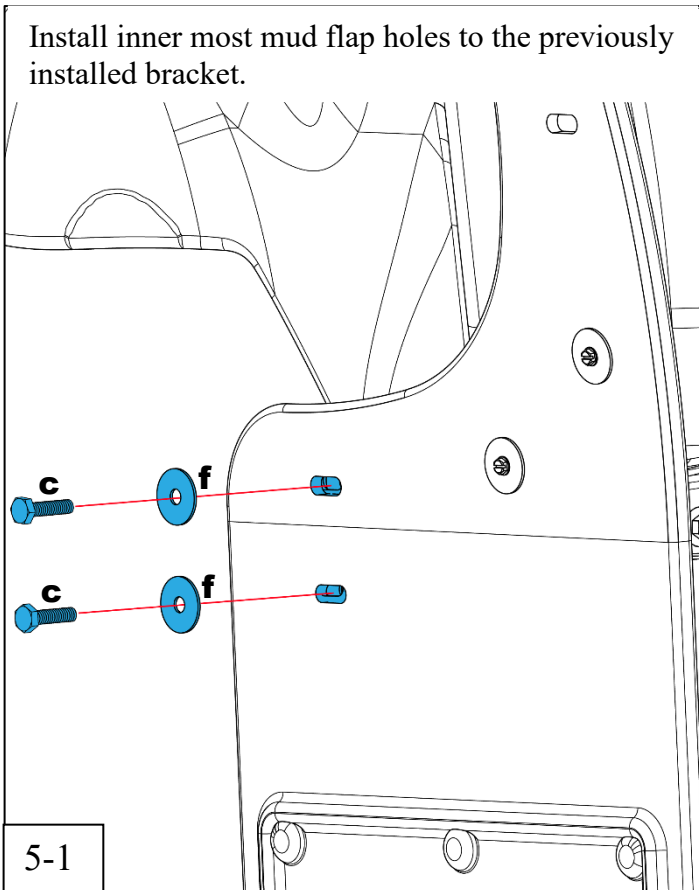

5-1

Install inner most mud flap holes to the previously installed bracket.

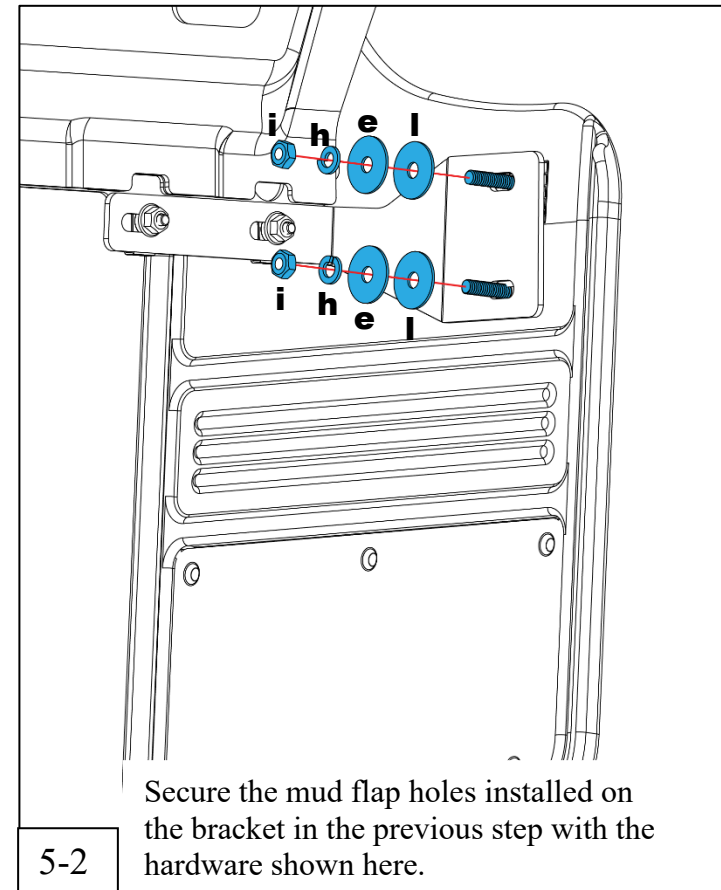

5-2

Secure the mud flap holes installed on the bracket in the previous step with the hardware shown here.

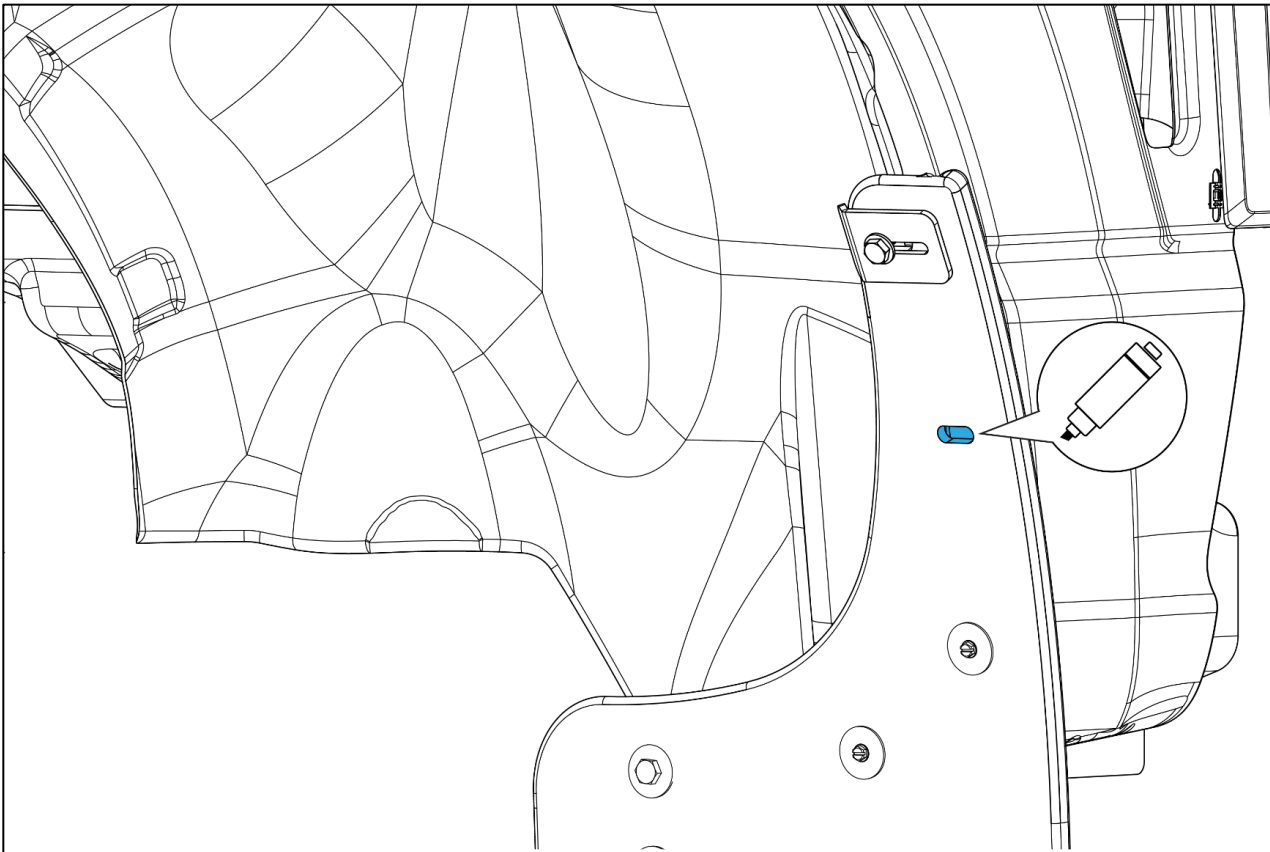

With the mud flap held tight to the fender lip, mark the fender through the remaining mud flap hole. This provides a guide for installing the protective tape and spring nut as shown in 6-2.

6-1

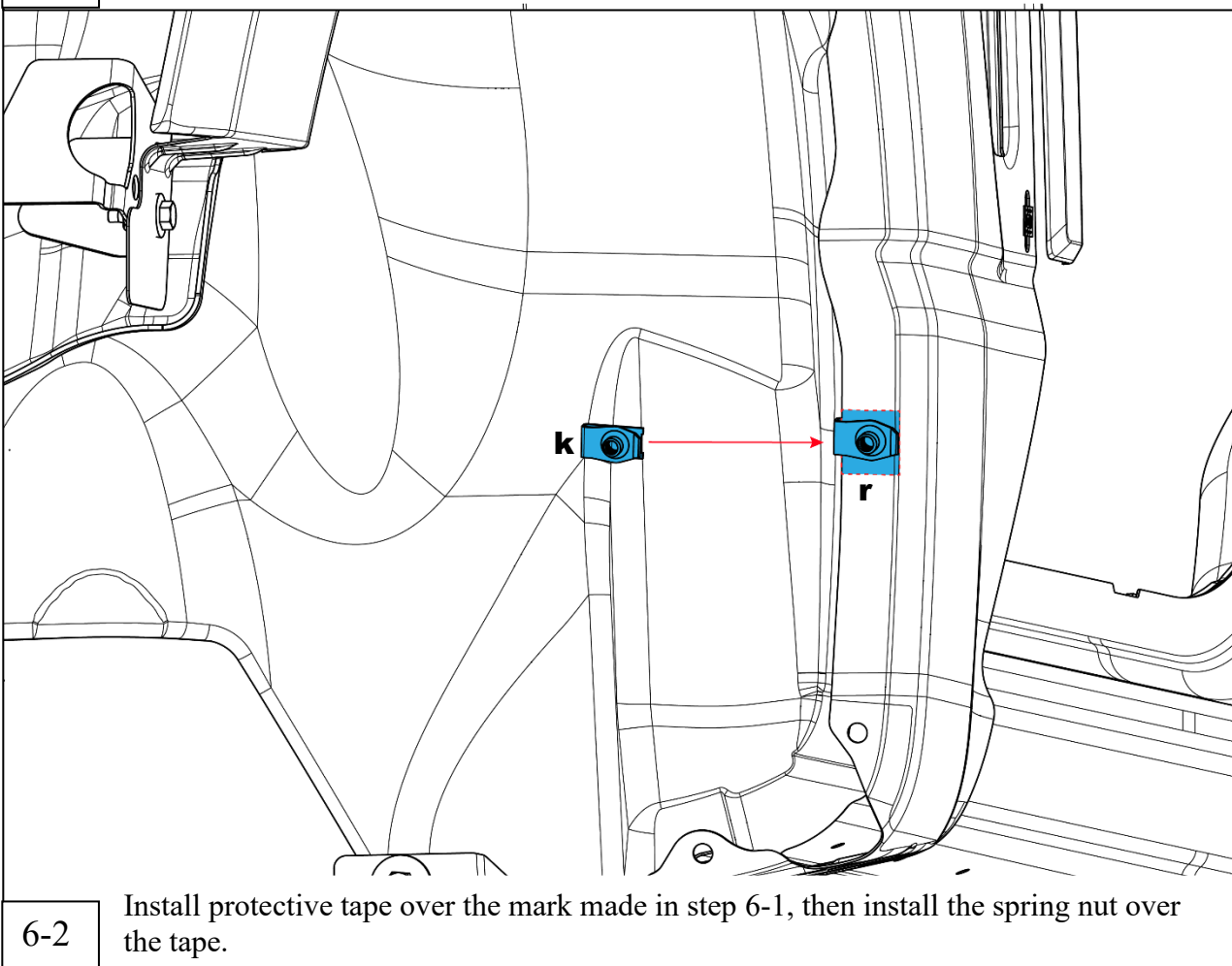

Install protective tape over the mark made in step 6-1, then install the spring nut over the tape.

6-2



6-3 Install the hardware shown here into the spring nut installed in 6-2.

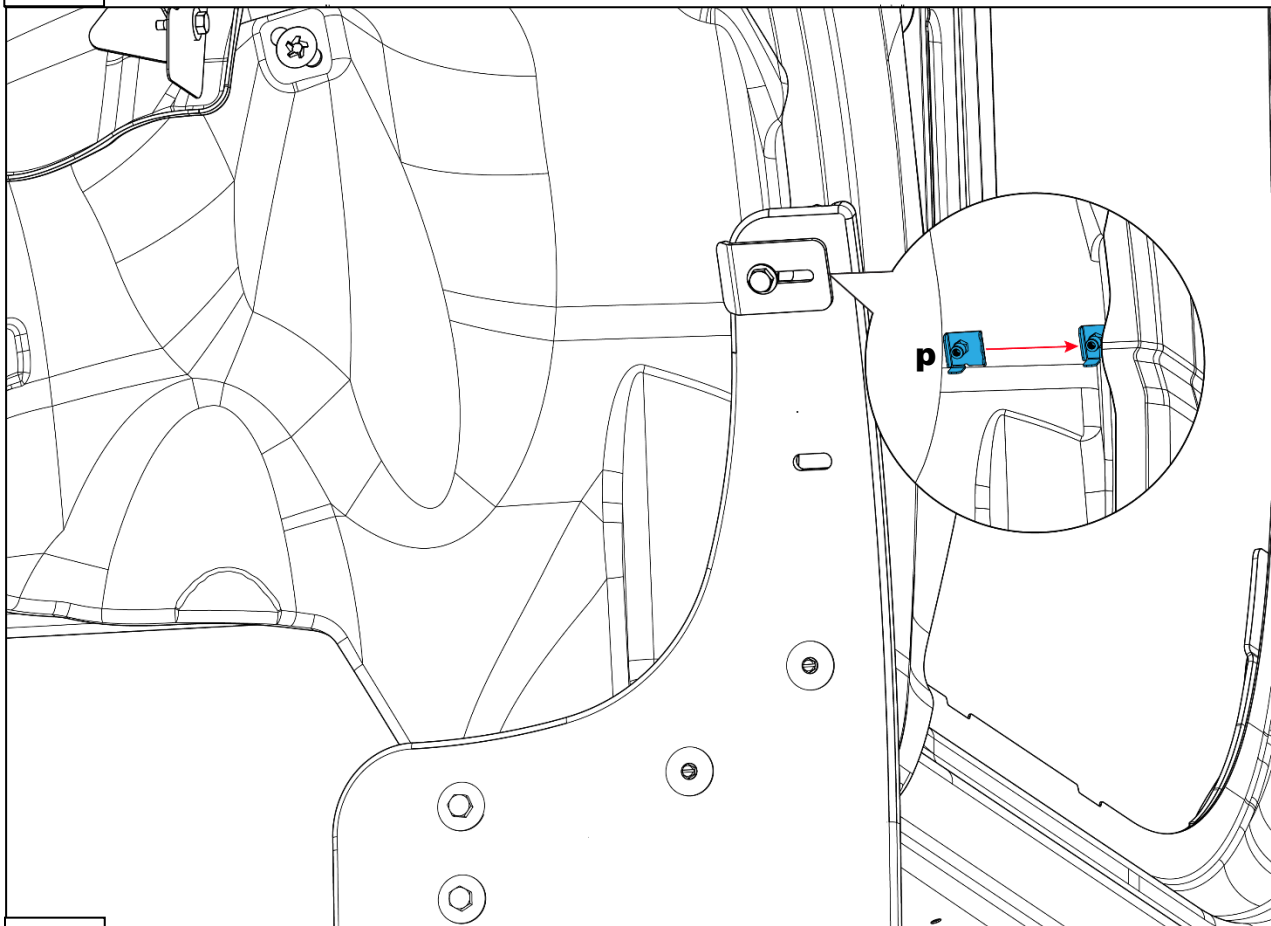

7-1 Slide the mount clip behind the fender lip as shown here

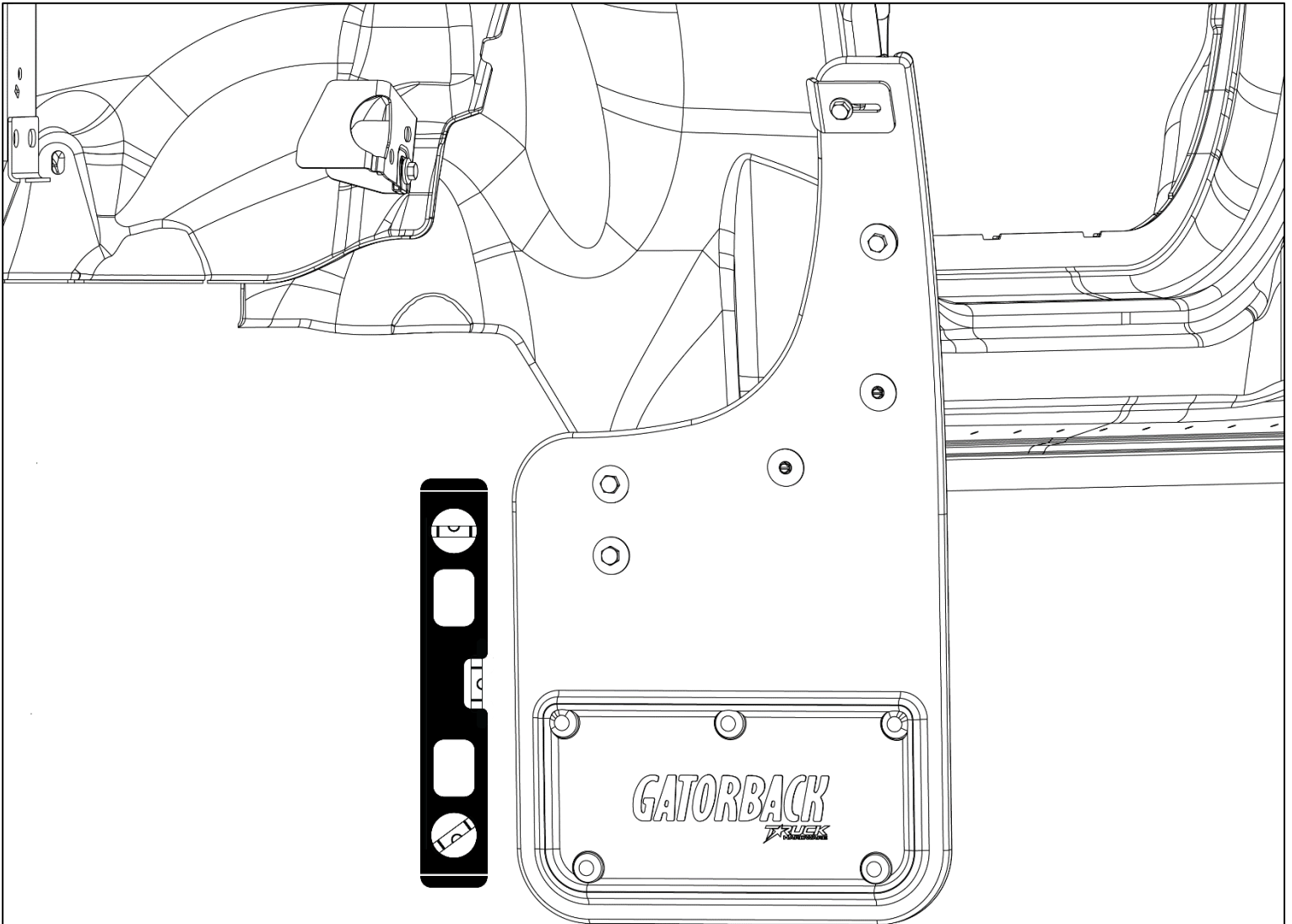

8-1 Use a level and visually determine your mud flap is straight. Gently tighten all fasteners.

Please check out our YouTube channel to see an install video for this application



IMPORTANT:

The manufacturer is not responsible for negligent use of vehicle with mud flaps installed, including over-tightening of screws and bolts causing damage to vehicle or mud flaps.

Before you install your Mud Flap Set, see the diagram and parts list for all necessary parts.

All hardware should be loosely installed until all mounting points have been installed and flap has been levelled. It is suggested that final tightening of hardware be done with hand tools to avoid over-tightening.

TOOLS REQUIRED:

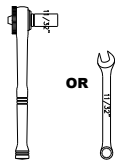

10mm open or
socket wrench

OR

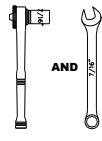

7/16" open and
socket wrench

AND

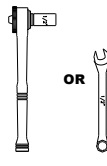

5/16" open or
socket wrench

OR



Push Pin
Removal Tool

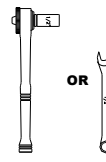

1/4" open or
socket wrench

OR



FLAPS AND BRACKETS

(1) Mud Flap
Driver Side

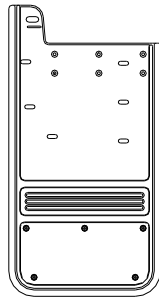

(1) Mud Flap
Passenger Side

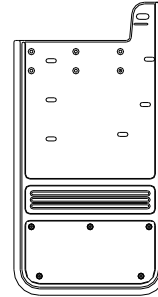

(1) Threaded Bracket
Driver Side
Part #770745



(1) Threaded Bracket
Passenger Side
Part #770746



(1) Mount Bracket
Driver Side
Part #770743

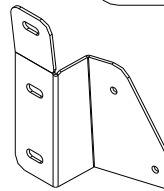

(1) Mount Bracket
Passenger Side
Part #770744

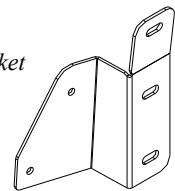

PARTS BAG # 770761

a) (4) Capscrew, SS
1/4" - 20UNC x 1"
Part #014007



b) (2) Capscrew, SS, Blk Ox.
1/4" - 20UNC x 3/8"
Part # 014069



c) (4) Capscrew, SS, Blk Ox.
1/4" - 20UNC x 3/4"
Part # 014070



d) (6) Capscrew, SS Blk Ox
1/4" - 20UNC x 1"
Part #014073



e) (4) Sht Mtl Screw
8-15 x 1.25" SS Blk Ox
Part #016059



f) (10) Washer, Flat
0.281" x 1" SS
Part #018068



g) (10) Washer, Flat
0.281" x 1" SS Blk Ox.
Part # 018069



h) (4) Washer, Flat
0.203" x 1" SS Blk Ox
Part # 018070



i) (8) Washer, Lock
1/4" Helicoil, SS
Part # 024000



j) (8) Hex Nut
1/4"-20, SS
Part # 025000



k) (2) Flange Nut
1/4"-20, Serrated
Part #025034



l) (2) Spring Nut
1/4"-20UNC, 0.54", SS
Part #028010



m) (2) Spring Nut
1/4"-20 UNC, 27/32", SS
Part #028011



n) (10) Washer, Nylon
0.318" x 1"
Part #054061

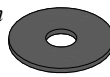

o) (4) Washer, Nylon
0.265" x 0.625" Blk
Part # 054071



p) (4) Washer, Nylon
0.281" x 1" Blk
Part # 054084



q) (2) J-Clamp
1.5" x 2.5"
Part #767417

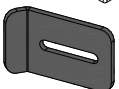

r) (1) Mount Clip
DS
Part # 769308

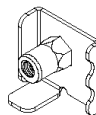

s) (1) Mount Clip
PS
Part #769309

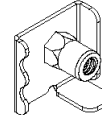

t) (1) Protective Tape
Universal, 2 pc.
Part #770681

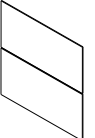

u) (2) Wedge Plate
Universal
Part #770747

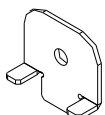

Installation/ Installation/ Instalación

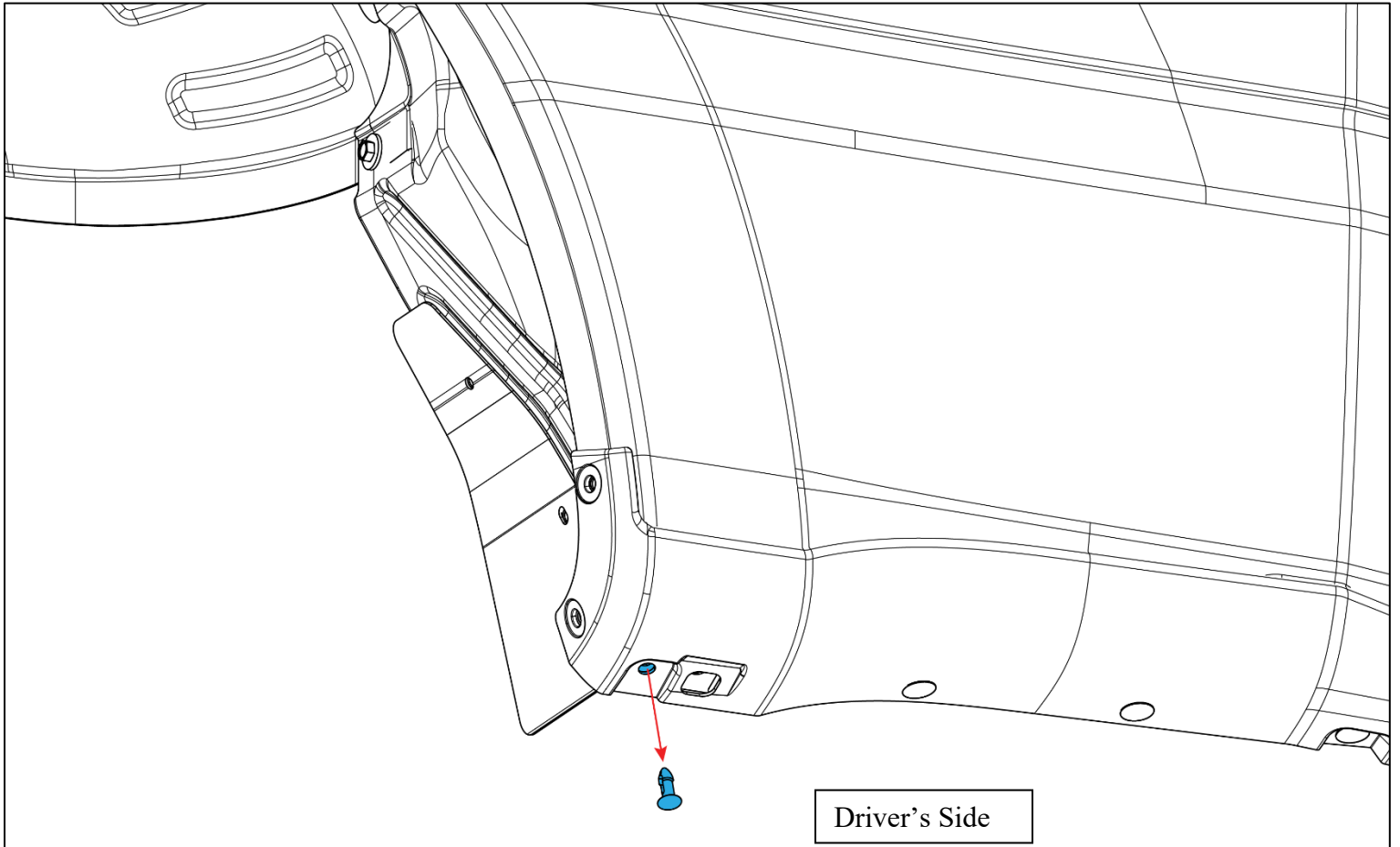

1-1 Remove factory push pin as shown

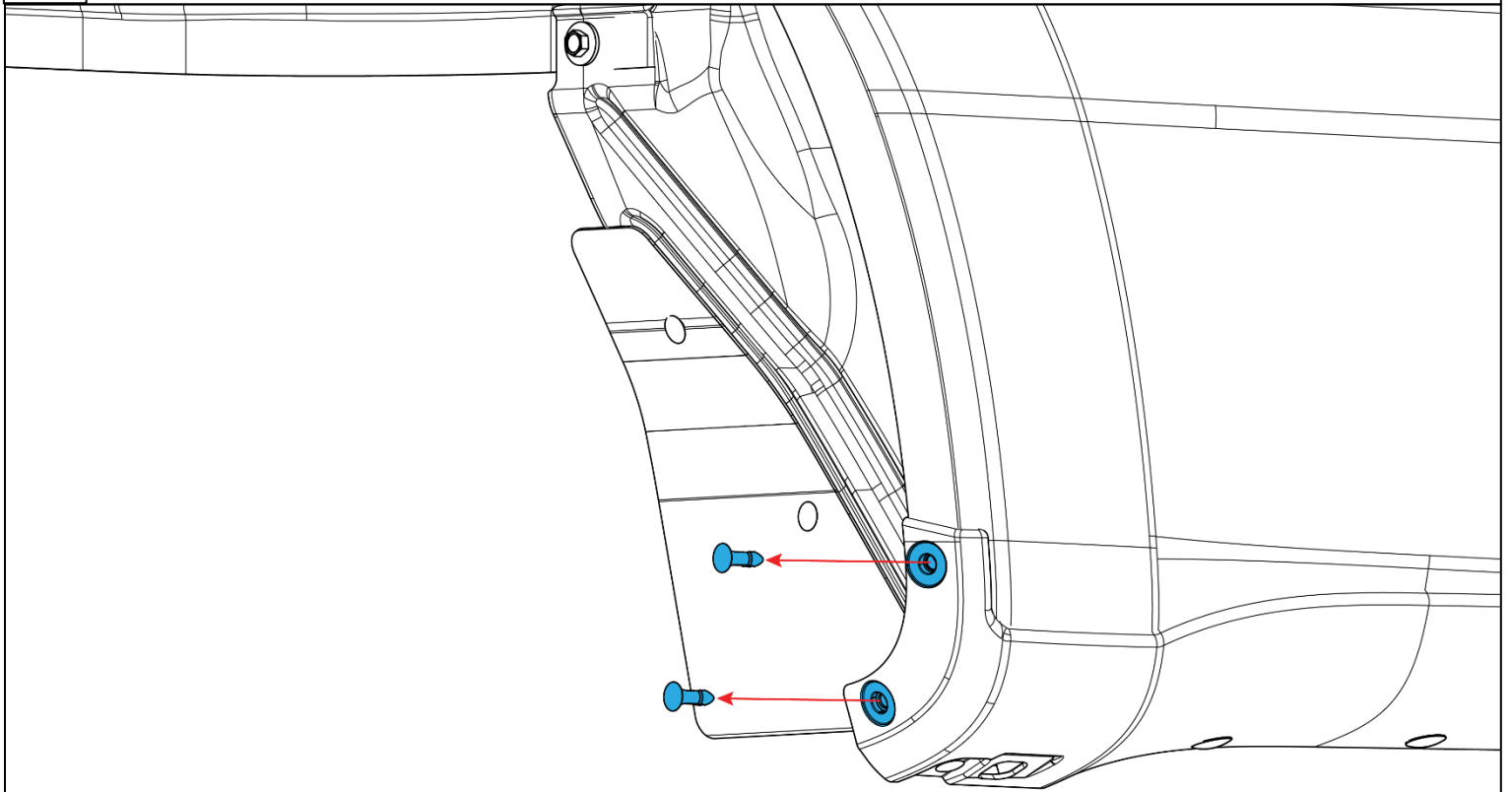

1-2 Remove factory push pins from fender as shown

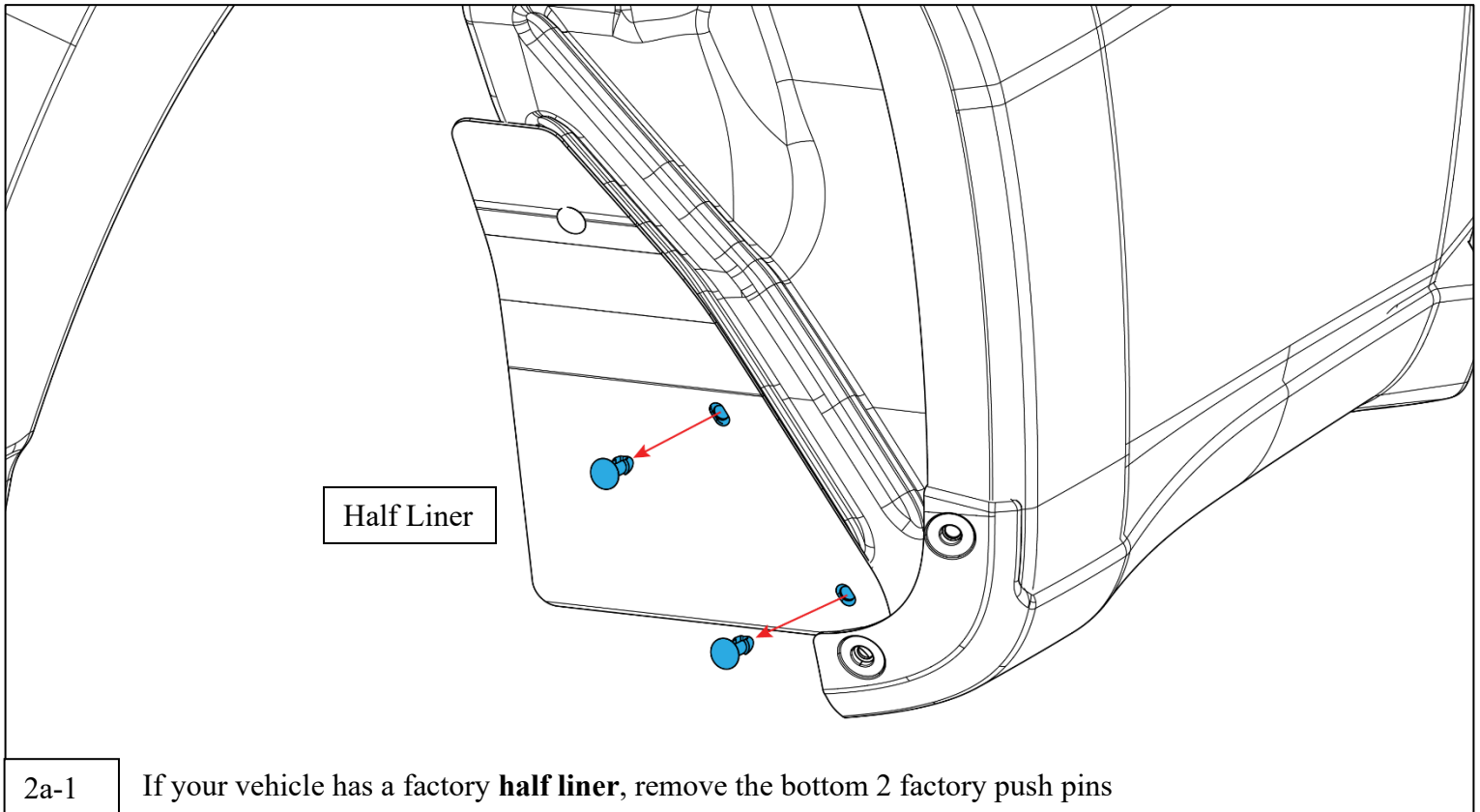

2a-1 If your vehicle has a factory **half liner**, remove the bottom 2 factory push pins

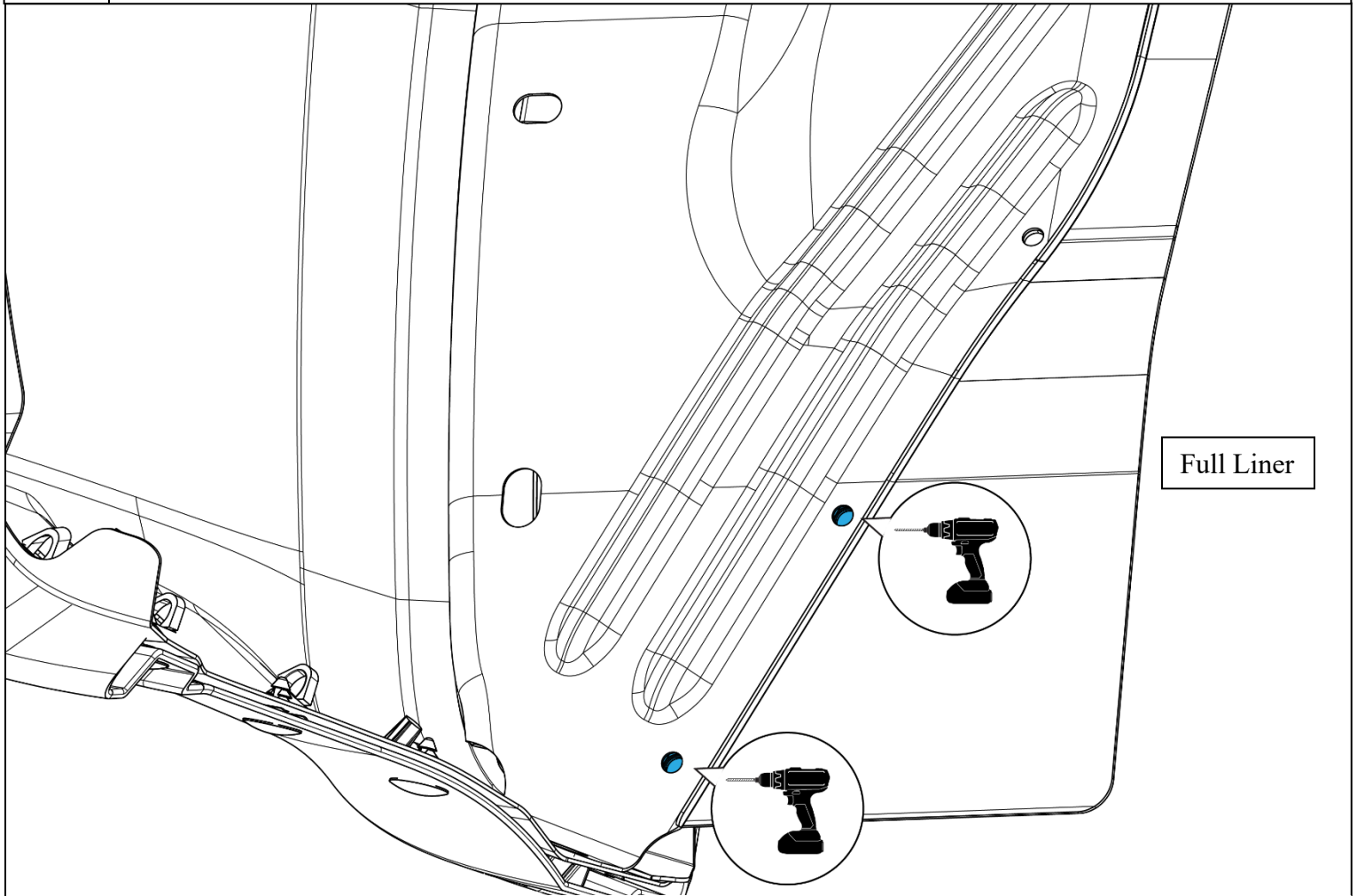

2b-1 If your vehicle has a factory **full liner**, drill pilot holes through the liner using the factory holes in the metal behind the liner as a guide.

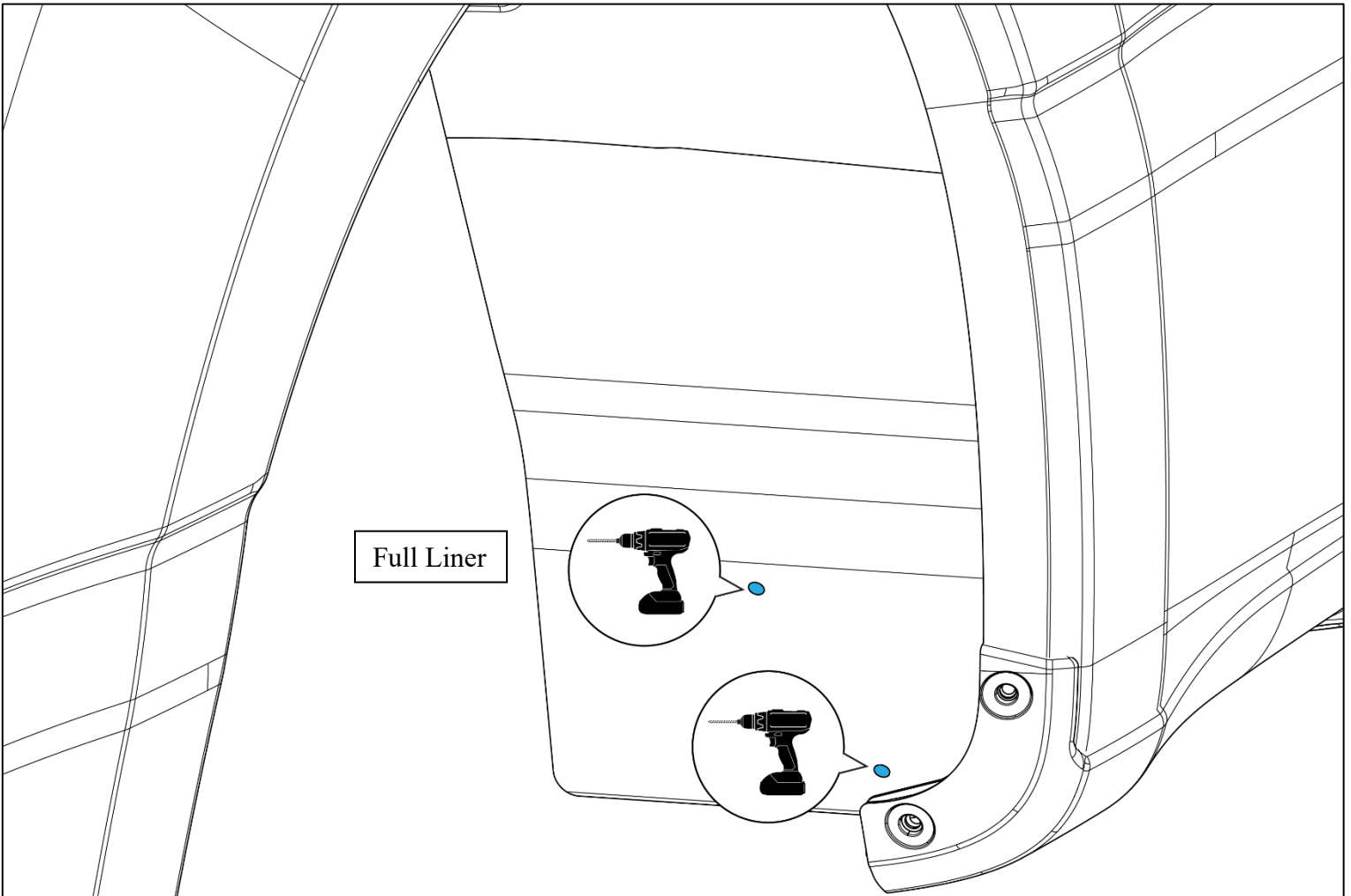

2b-2

From the front of the liner, enlarge the pilot holes drilled in 2b-1 to a minimum of 9/32". Use caution to not allow the drill bit to come into contact with parts of the vehicle hidden behind the liner.

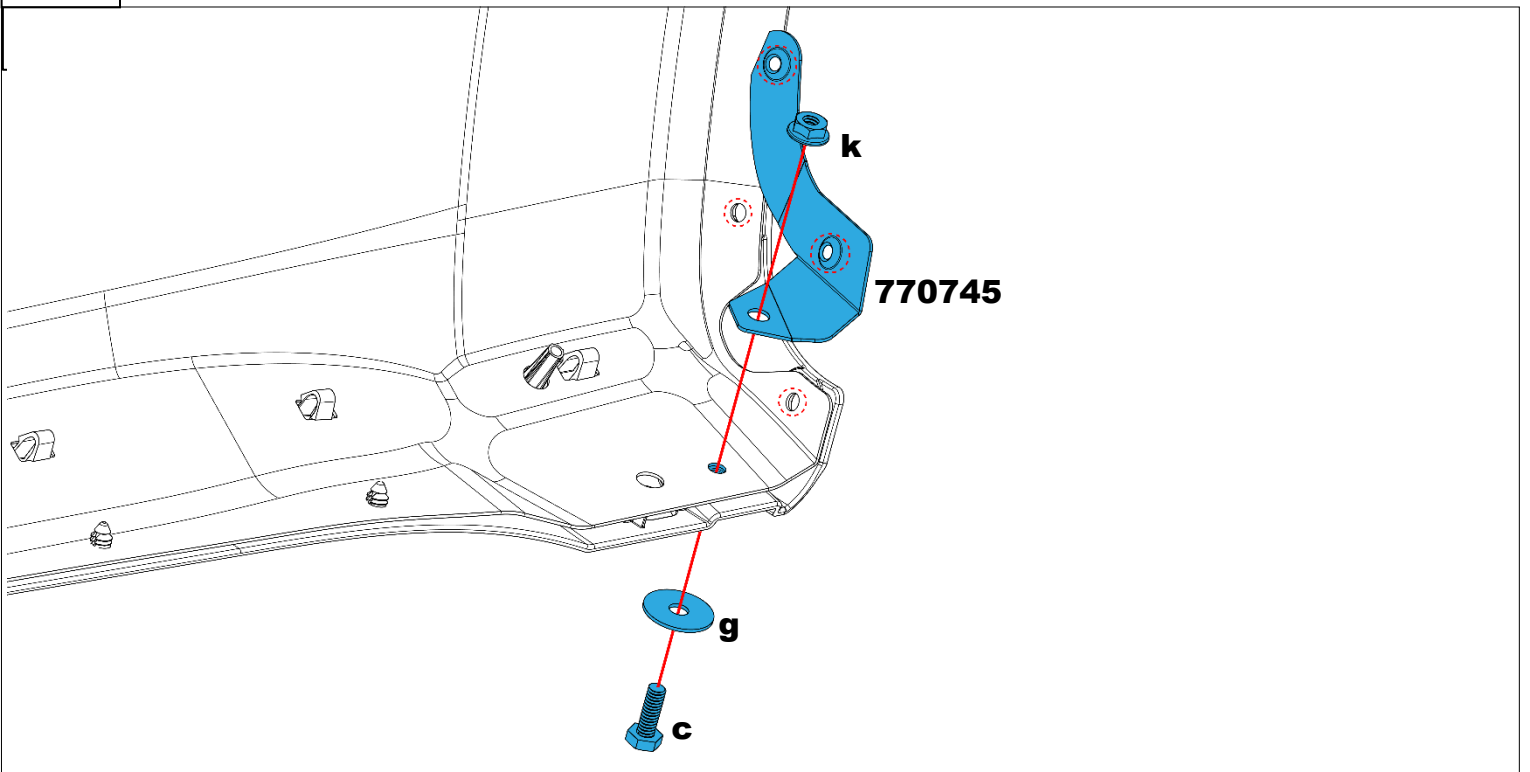

3-1

Install bracket and hardware as shown on factory hole where push pin was removed in step 1-1, ensuring the threaded holes in the bracket line up with the factory holes in the fender lip

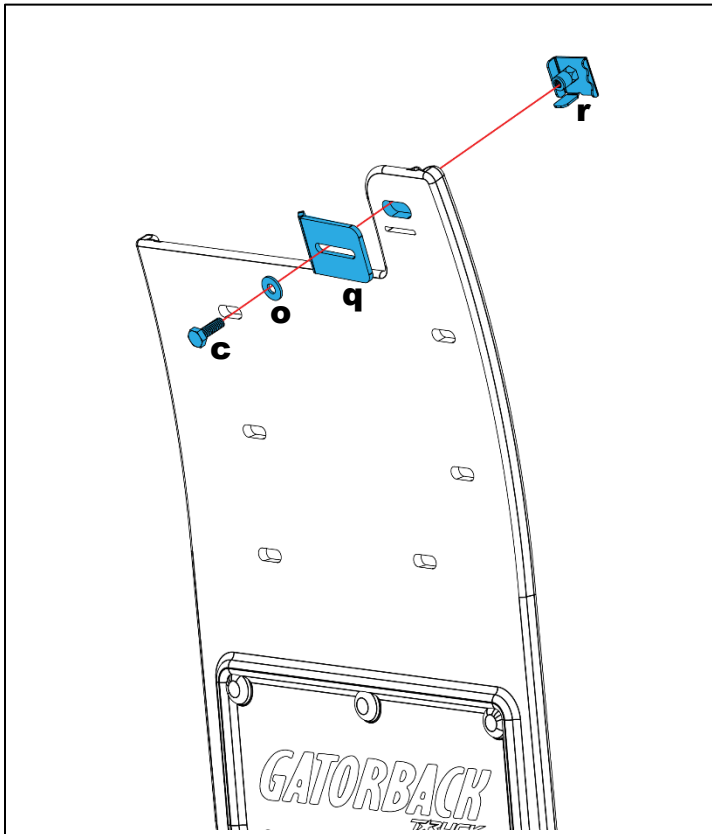

Loosely install mount clip to top mud flap hole. Do not install on the fender lip at this time.

4-1

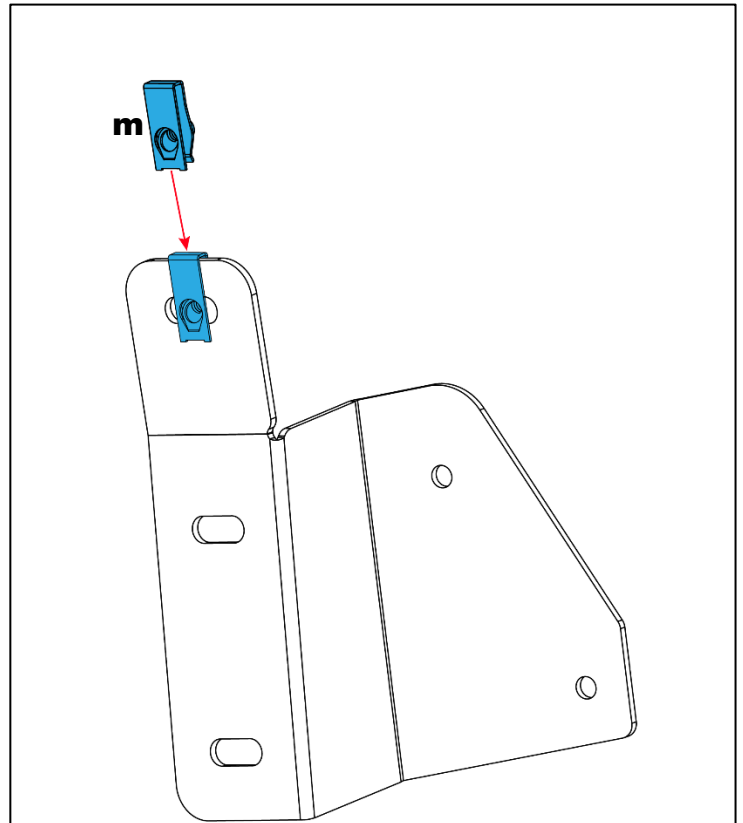

Install spring clip on bracket

5-1

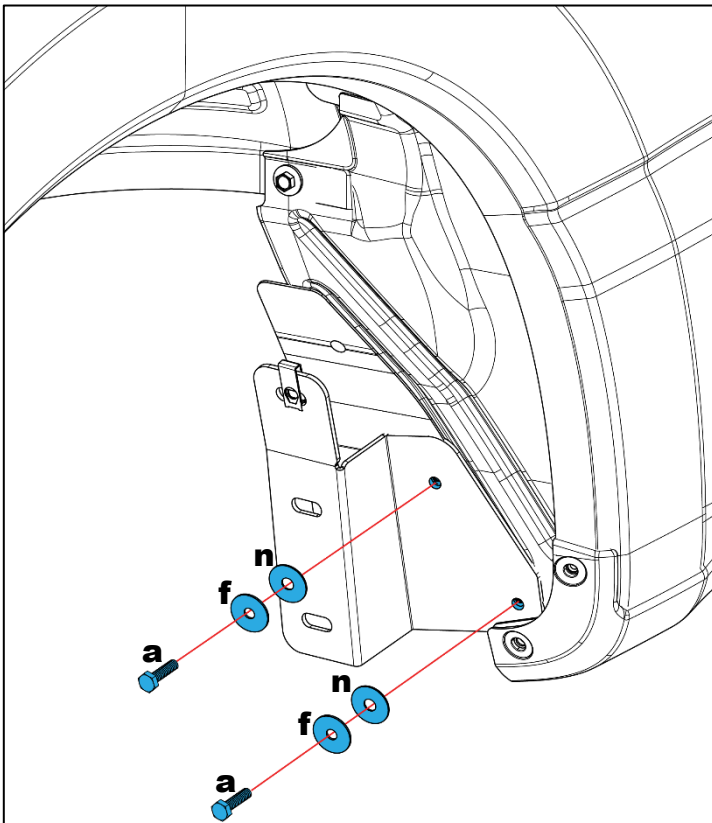

Install bracket as shown

6-1

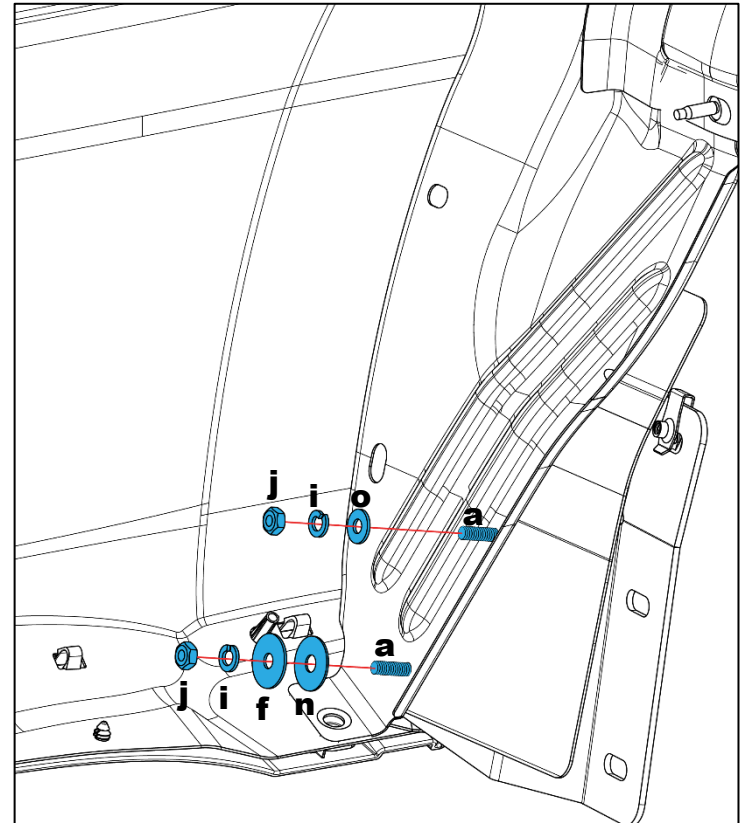

Secure bracket installed in 6-1 as shown

6-2

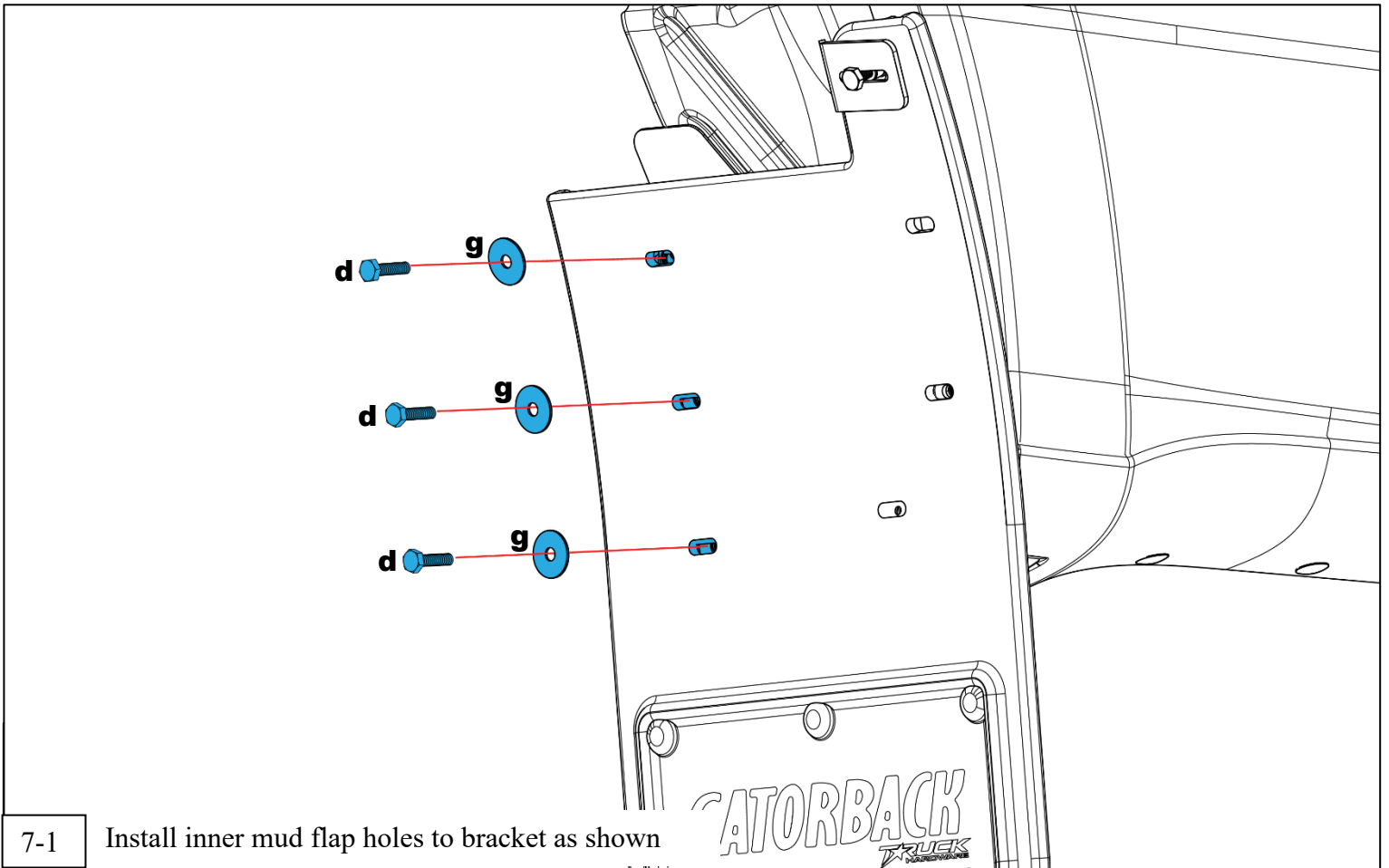

7-1 Install inner mud flap holes to bracket as shown

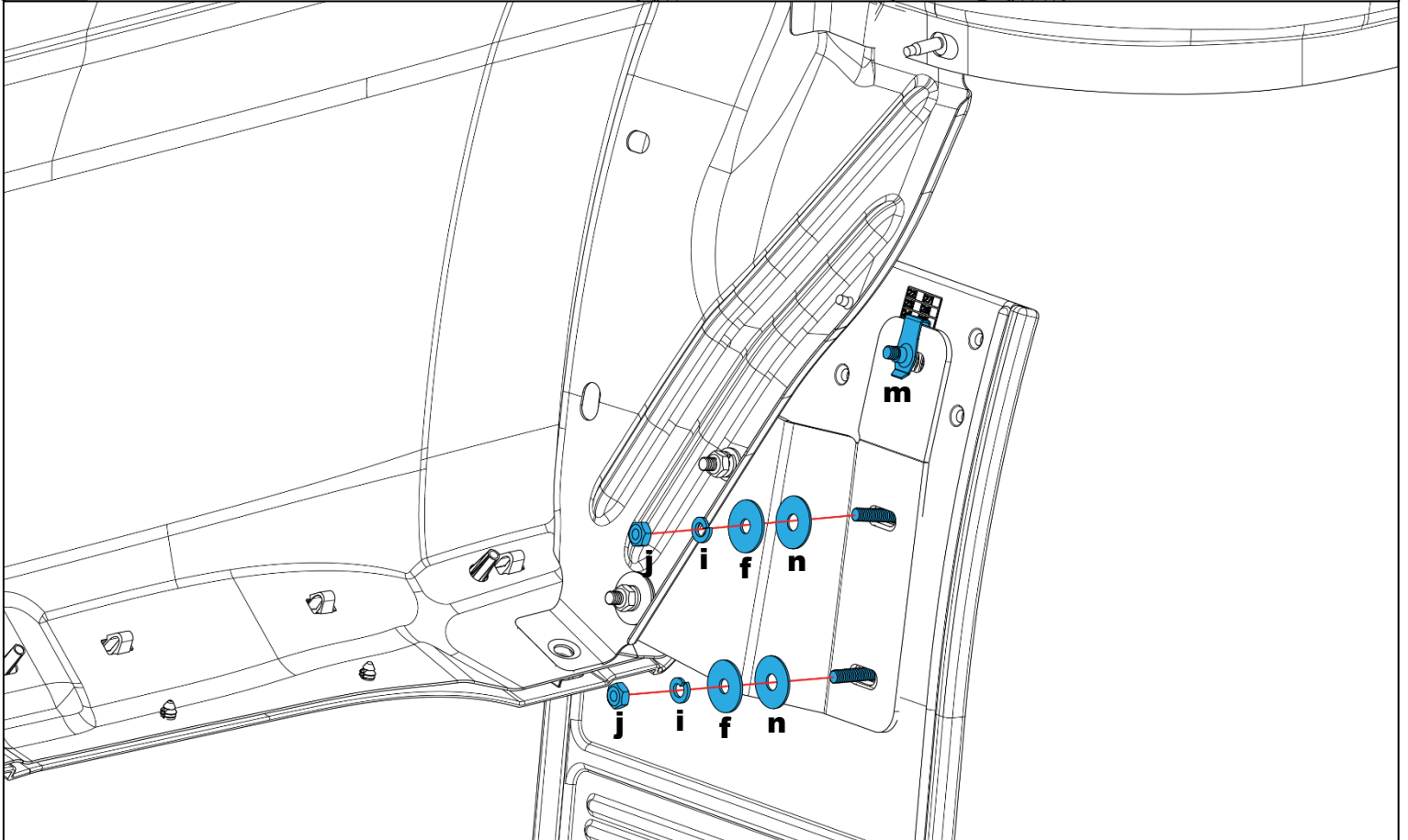

7-2 Secure hardware on bottom 2 holes as shown. Note: Top hole is secured on the spring nut installed in step 5-1

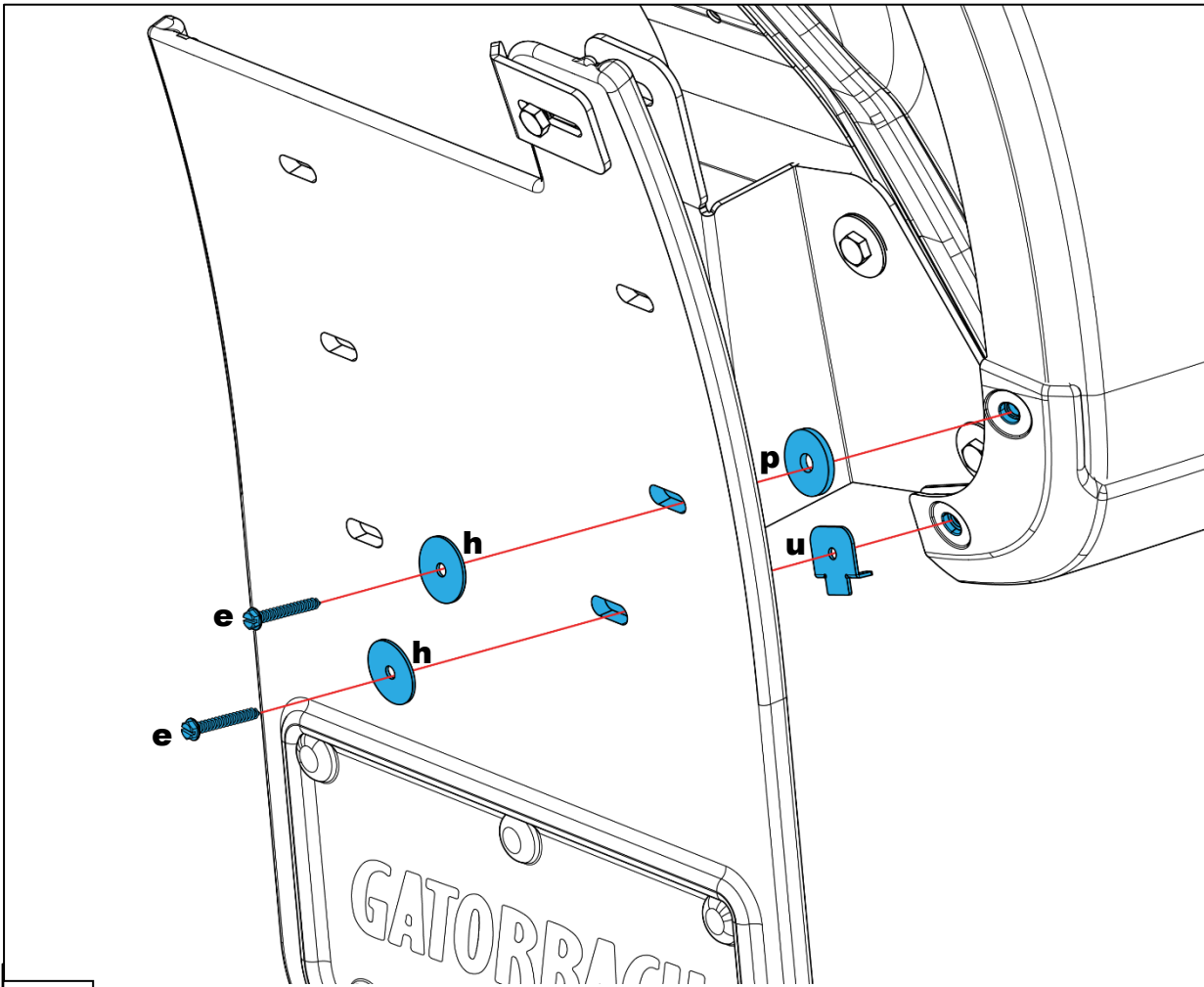

8-1 Install mud flap holes into threaded bracket behind factory holes as shown

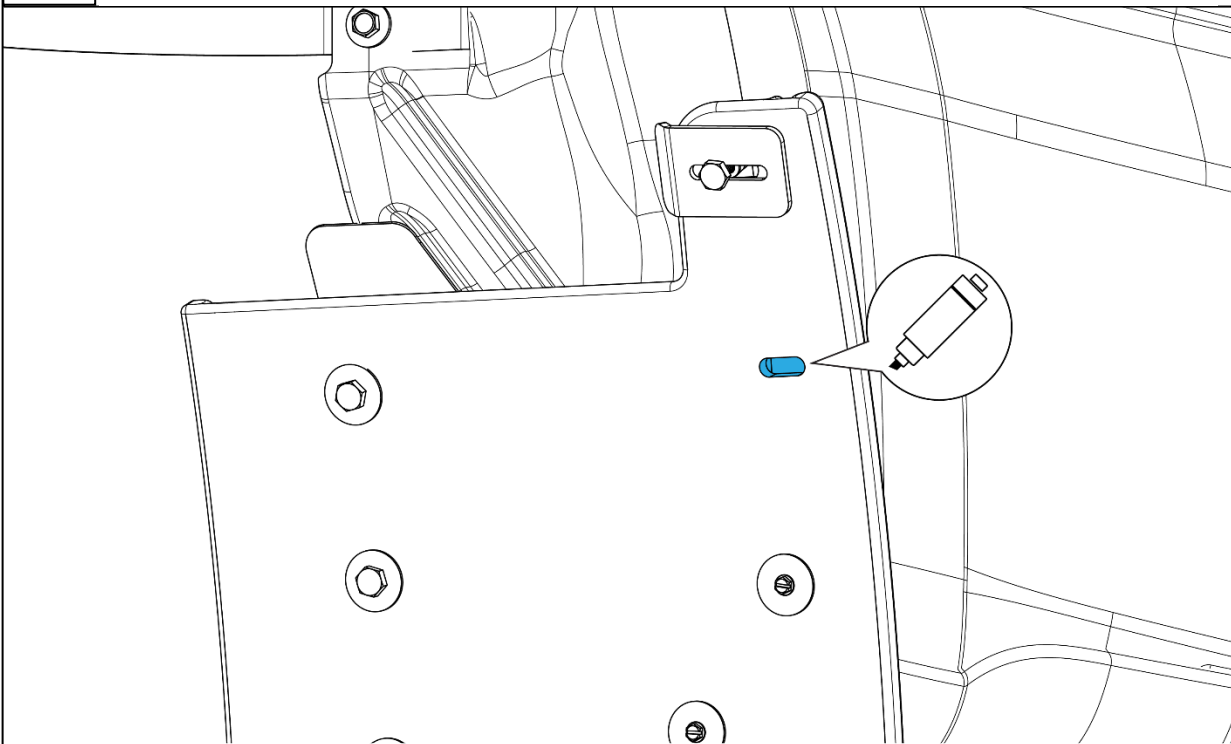

9-1 With the mud flap held tight to the fender lip, mark the fender through the remaining mud flap hole. This provides a guide for installing the protective tape and spring nut as shown in 9-2.

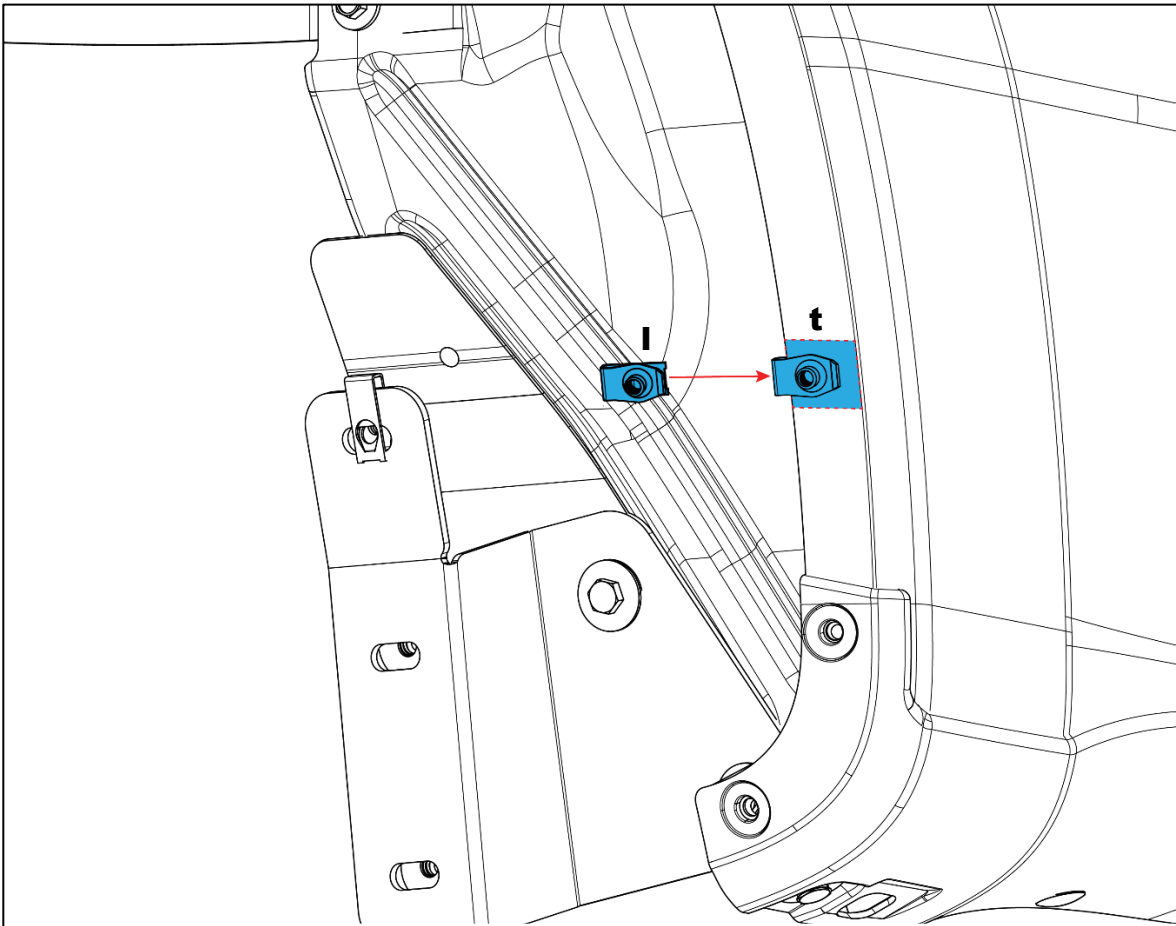

9-2 Install protective tape over the mark made in step 9-1, then install the spring nut over the tape.

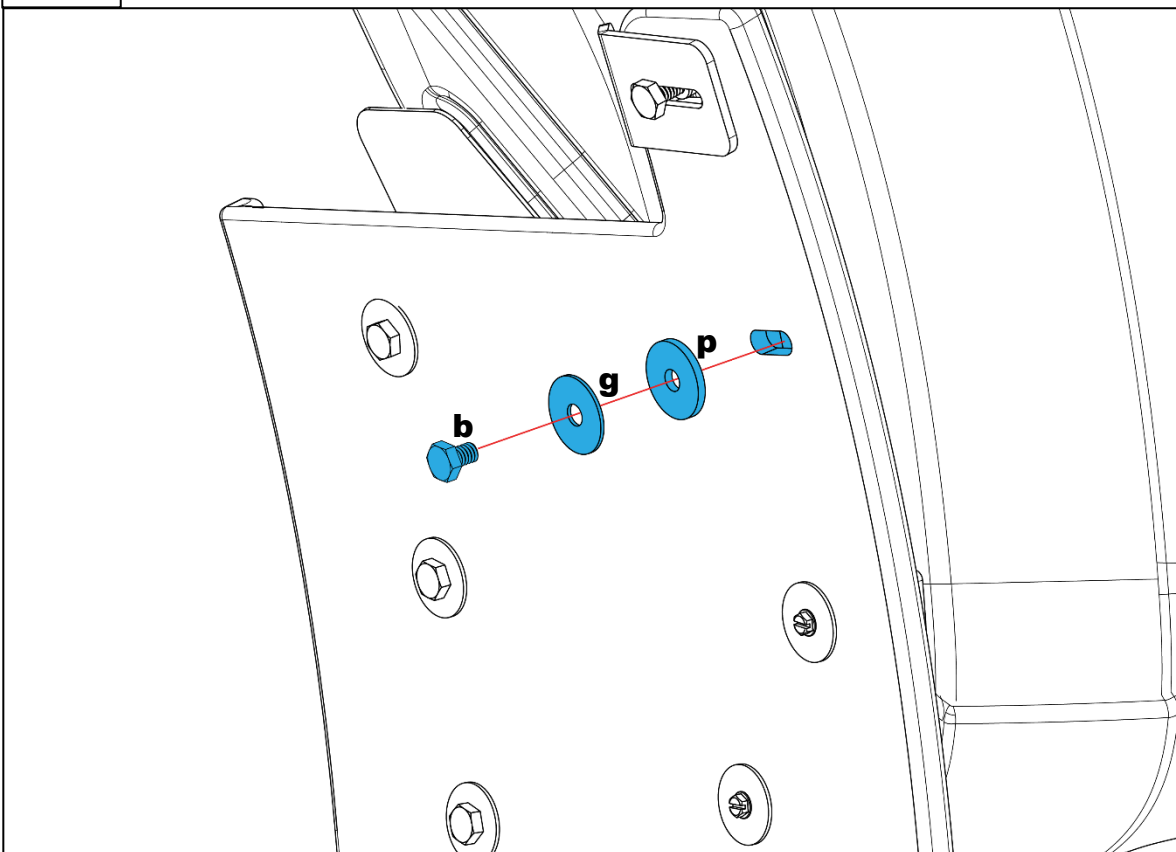

9-3 Install the hardware shown here into the spring nut installed in 9-2.

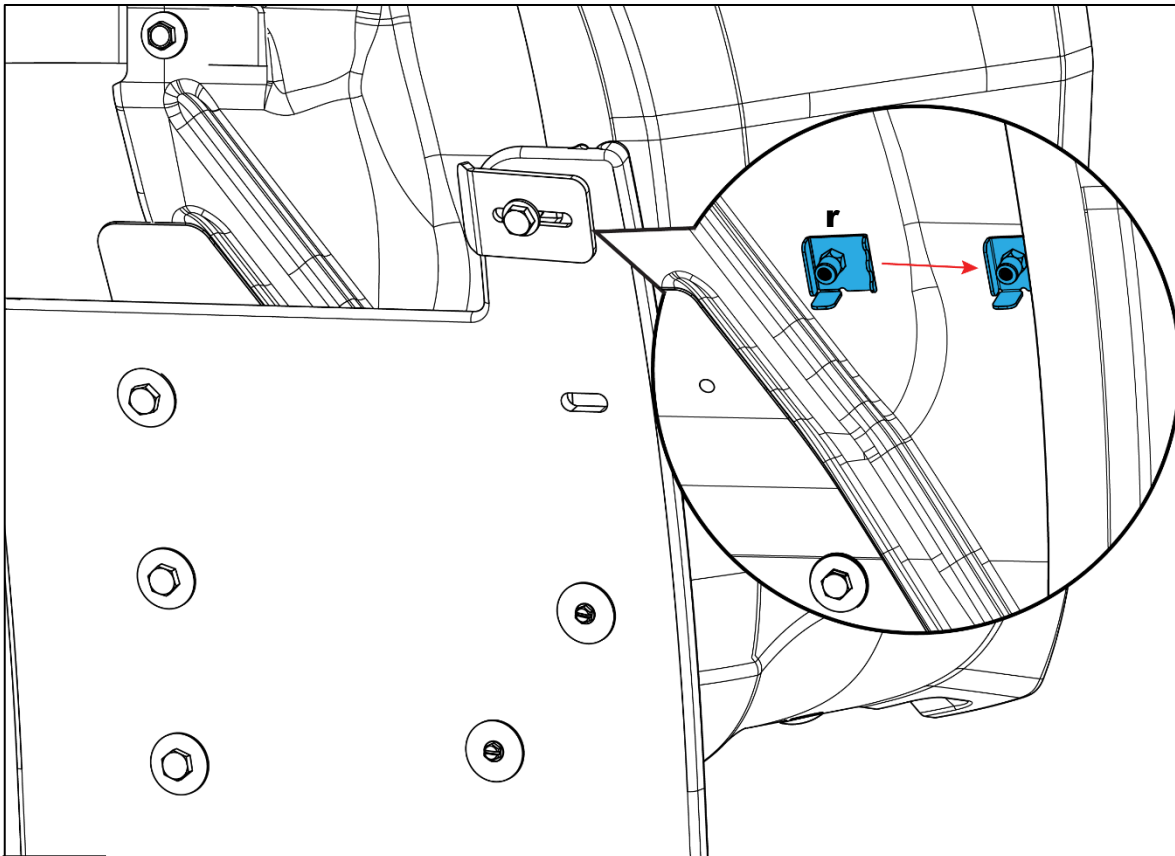

10-1 Slide the mount clip behind the fender lip as shown

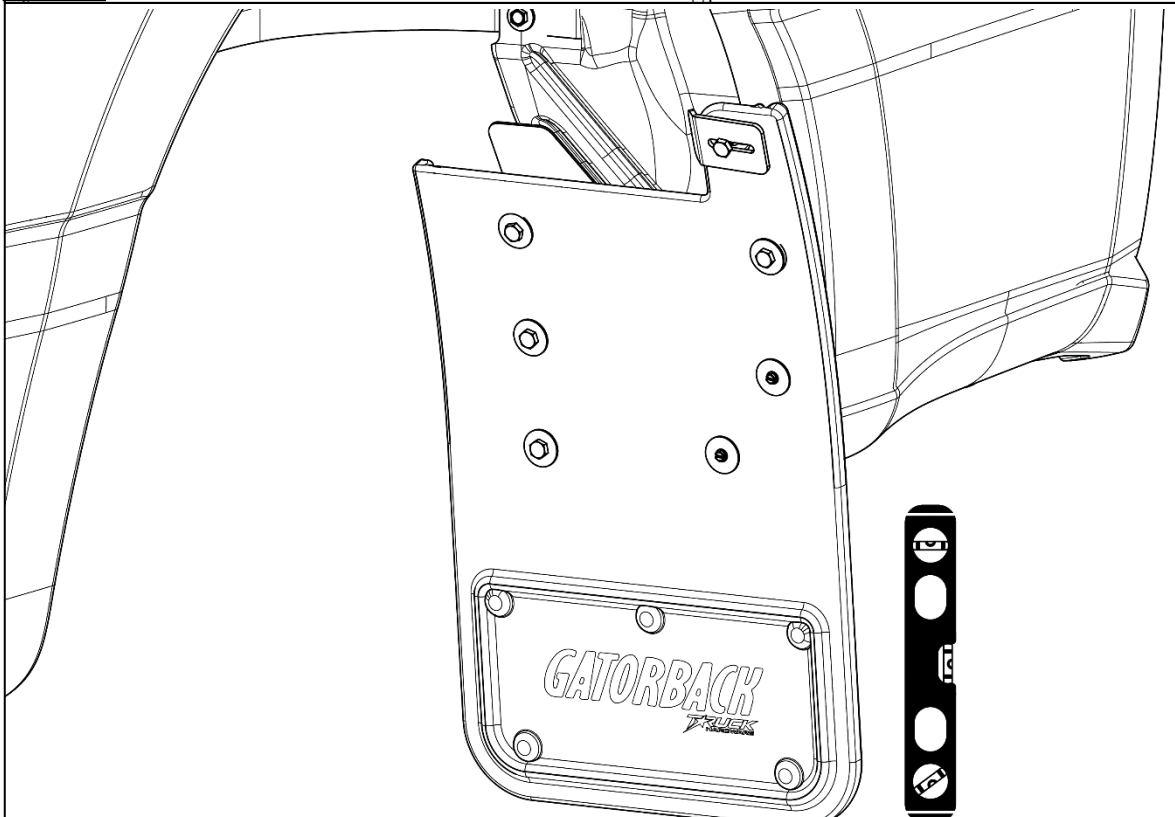

11-1 Use a level and visually determine your mud flap is straight. Gently tighten all fasteners.

Please check out our YouTube channel to see an install video for this application

