

Components and Hardware: HWKT-00195X

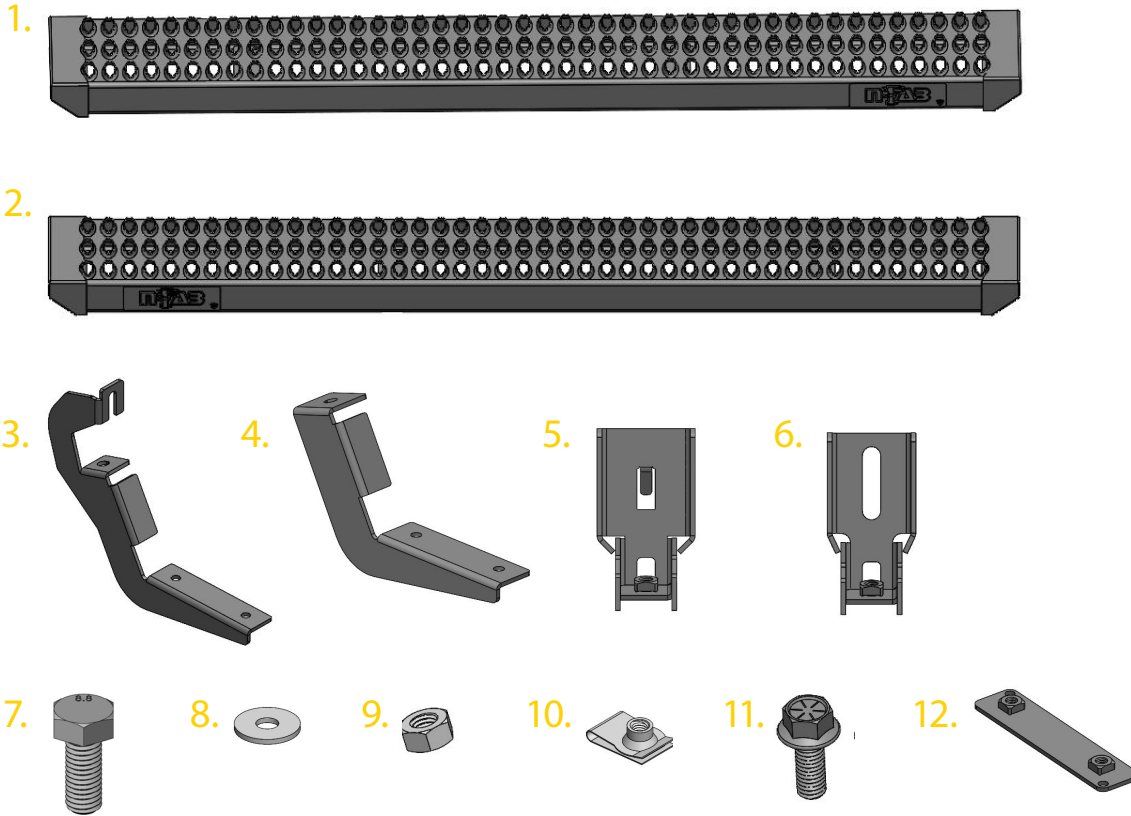

Components and Hardware:

1. Driver side board.....	(1)
2. Passenger side board.....	(1)
3. Mounting bracket.....	(5)
4. Mounting bracket.....	(2)
5. Mounting bracket.....	(1)
6. Mounting bracket.....	(1)
7. M8-1.2x25mm hex bolt.....	(13)
8. M8 fender washer.....	(18)
9. M8-1.25 hex nut.....	(5)
10. M8-1.25x20mm Barrel U-clip.....	(3)
11. 3/8"-16x1" flanged hex bolt.....	(14)
12. Clamp plate.....	(7)

Tools for Installation:

- Ratchet wrench
- 13mm wrench
- 13mm socket
- 9/16" socket

INSTALL

Step 1. Look on the underside of the body and locate the factory mounting locations.

Step 2. If your vehicle is not equipped with upper threaded holes, remove the plastic body plugs and install the supplied (#10) barrel u clips.



Step 3. Beginning with the driver side, install (#3)x3 mounting brackets using the supplied (#7)x6 M8x25mm hex bolt, (#8)x9 M8 fender washer and (#9)x3 M8 hex nut and loosely fasten.

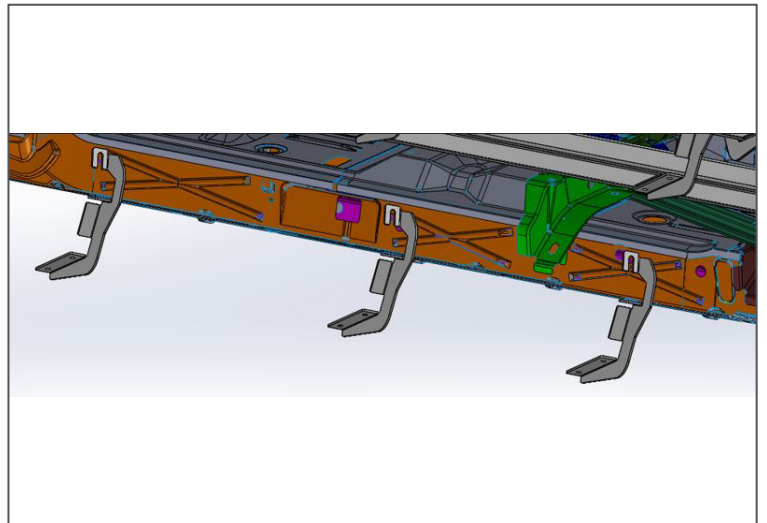

Step 4. Set running board along the top x3 brackets and center along the cab.

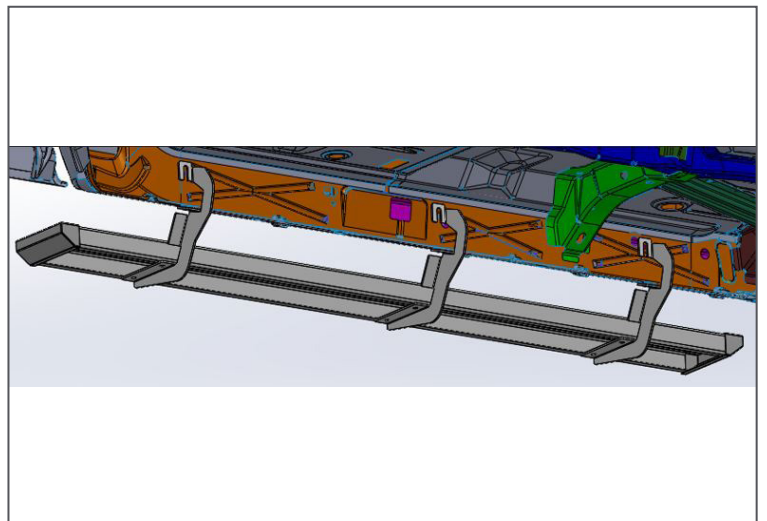

INSTALL

Step 5. Insert the supplied threaded clamp plate (#6)x3 inside the running board lip over the top of each bracket.

Step 6. With the supplied (#11)x6 3/8" x 1" hex bolts, secure each mounting location and leave loose.

Step 7. After final adjustment, tighten all running board threaded mounts. (35 ft/lbs)

Step 8. Next, adjust frame brackets so the running board is level with body of the vehicle and tighten all factory mounting locations. (15-20 ft/lbs)

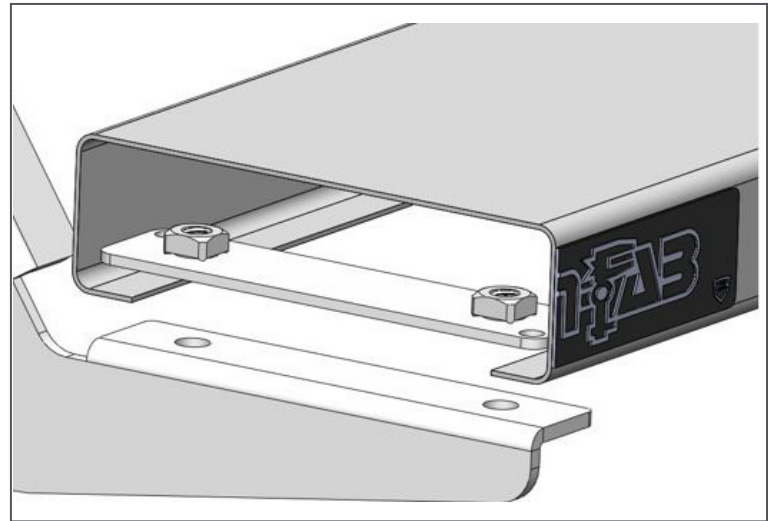

Step 9. For passenger side, remove the (x3) 13mm bolts, (x2) 10mm bolts and (x2) 10mm nuts that attach the Def tank cover. Remove and set aside.

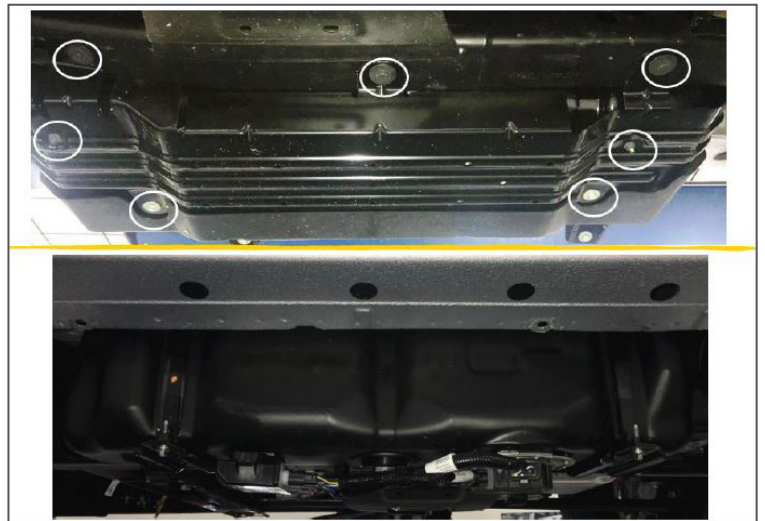

Step 10. Feed (#5)x1 upper bracket between the body and the Def tank until you locate the tab into the OE hole. The bracket will hang once placed correctly.

Step. 11. The second bracket will attach to the body with one of the supplied (#7)x1 M8x25 mm hex bolts and (#8)x1 M8 fender washer.

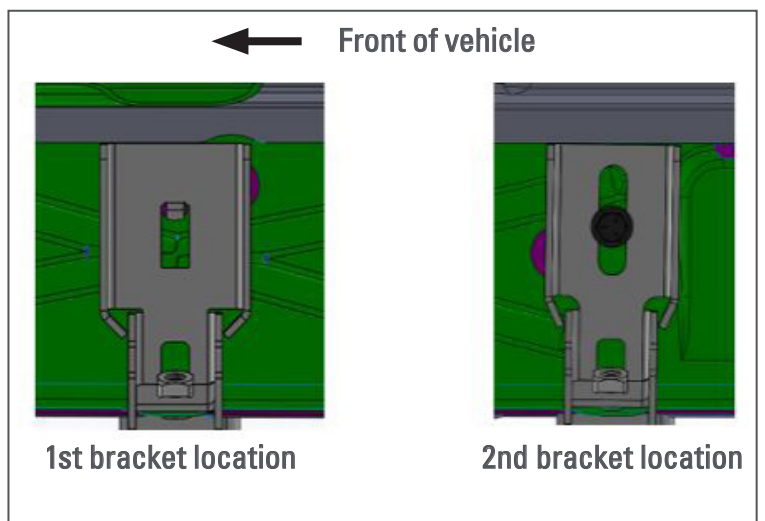

INSTALL

Step 12. Using the supplied (#7)x4 M8x25mm hex bolts and (#8)x6 washers begin hand tightening both upper and lower mounts to the rear two brackets.

Step 13. Next, attach the two front brackets to the rocker panel brackets that you installed in steps 10, 11 and hand tighten.

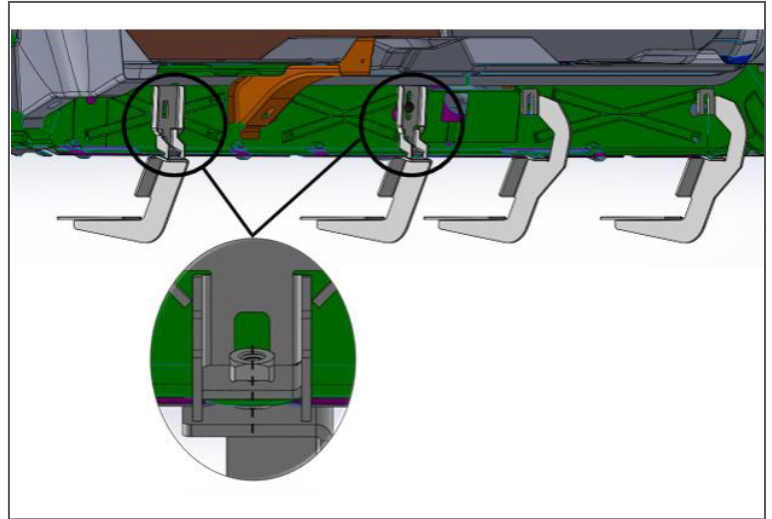

Step 14. Repeat the board install like in steps 5-7.

Step 15. Tighten all mounting bracket hardware to (20 ft/lbs).

Step 16. Re-install the DEF tank cover that was removed in step 9 and tighten to factory specs.

