



n-fab.com

a TRUCK HERO company

nfabinc f t

I-SHEET NUMBER: INST-00006  
 PART NUMBER: GFC19-CCTX, GFC19-QCTX  
 PRODUCT: GROWLER RUNNING BOARD  
 APPLICATION: 2019-20 CHEVY/GM CC/QC  
 1500/2500/3500/GAS /DIESEL

HARDWARE DESCRIPTION		QTY.
HWKT-00024X		
FLBW-00894	M8-1.25 X 30MM CLASS 8.8 FLANGE CAP SCREW W/WASHER	12
FLHB-00688	3/8"-16 X 1" GRADE 5 HEX SERRATED FLANGE BOLT	12

PARTS INCLUDED	QTY
Running Boards	2
Rocker Panel mounting Brackets	6
Threaded clamp plates	6



# GROWLER

**DO NOT USE IMPACT TOOLS**

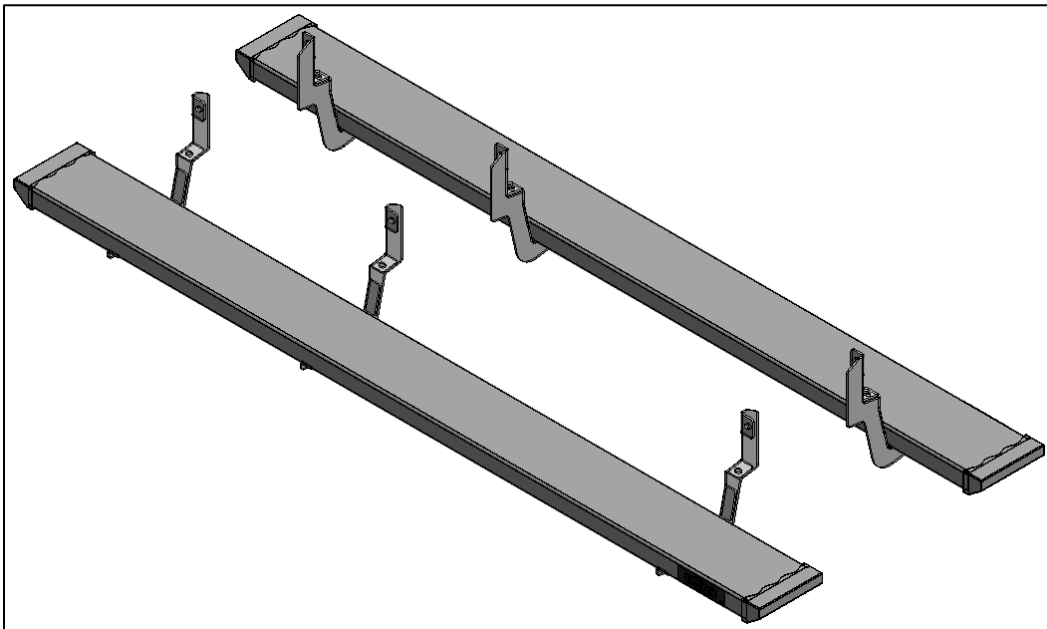

**Step 1:** Beginning with the driver side, remove factory-running bars if equipped and discard. You will see the 8mm threaded mounts in the body. Do the same with passenger side.

**Step 2:** Next, install the (x3) rocker panel mounting brackets to the factory attachment points using the supplied M8X30mm Hex Cap Bolt with washer and leave loose at this time.

**Step 3:** Set running board along the top of the three brackets and center along the cab front/back.

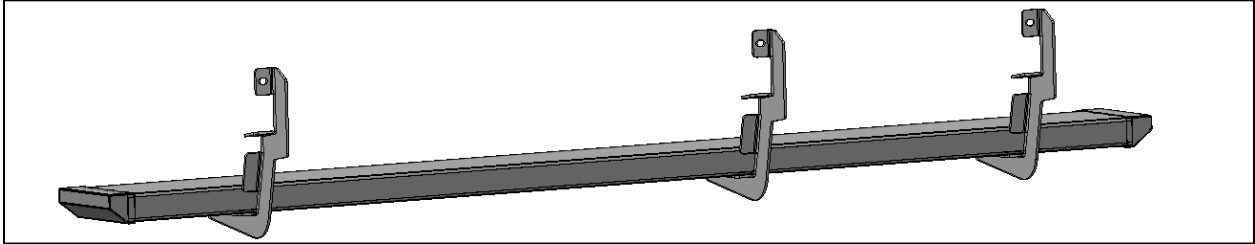

**Step 4:** Insert the supplied threaded brackets (x3) inside the running board lip over the top of each bracket.

**Step 5:** With the supplied 3/8" x 1" hex bolts, secure each mounting location and leave loose.

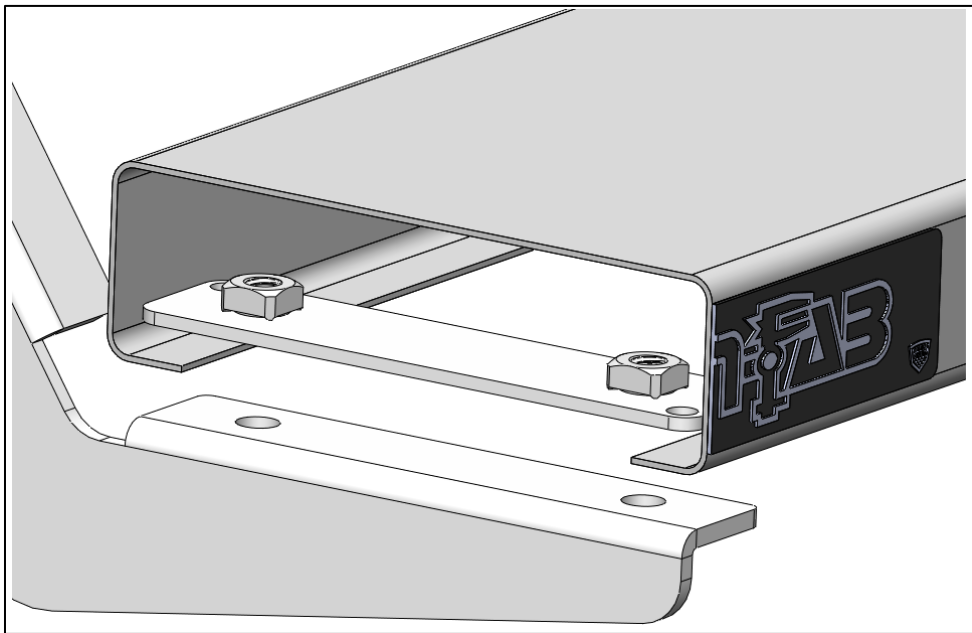

**Step 8:** After final adjustment, tighten all running board threaded mounts.

**Step 9:** Next, tighten the lower pinch weld attachment points (x3).

**Step 10:** Finish by tightening the upper mounts (x3).

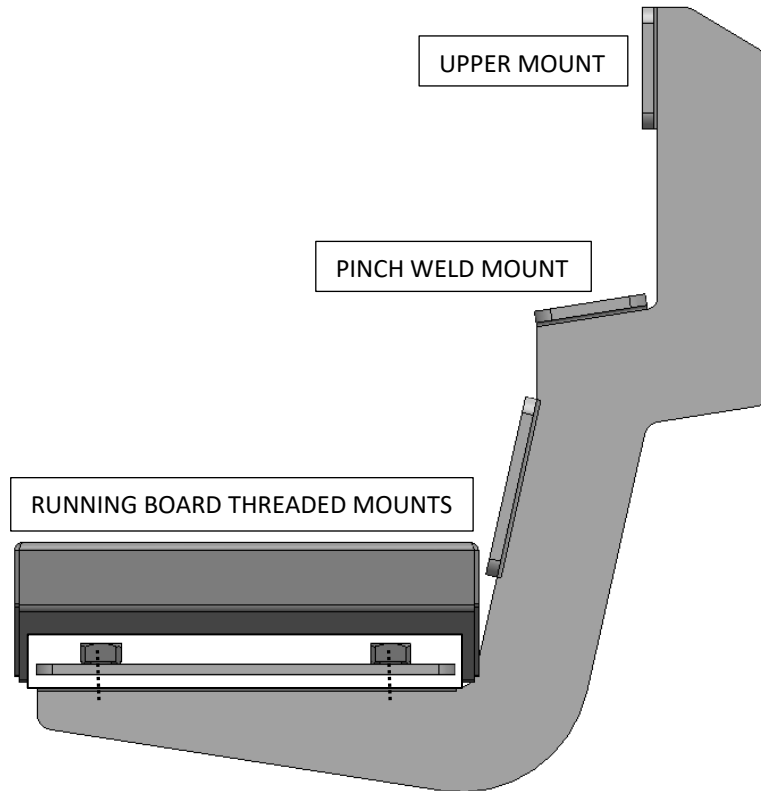

**Step 9:** Re-peat with passenger side.