

AMP RESEARCH Power Step

MADE IN USA

APPLICATION	MODEL YR	PART #
Hummer H3	2006 - 2010	75116-01A
Hummer H3T	2009 - 2010	75116-01A

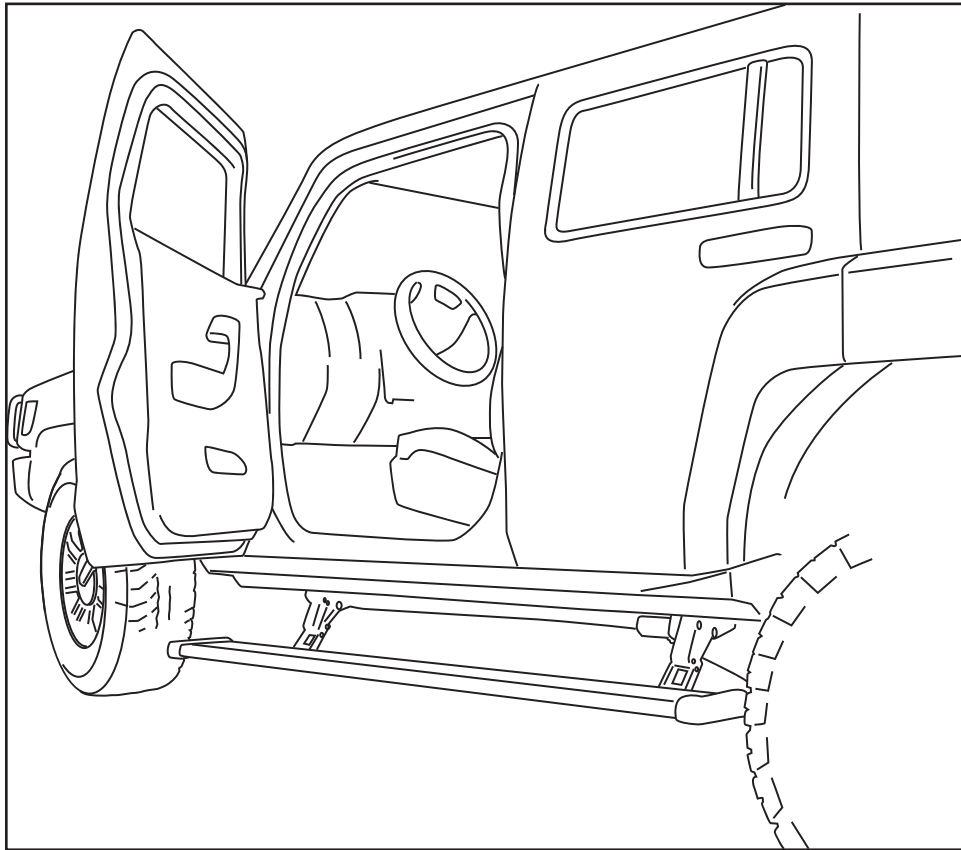

INSTALLATION TIME

3-5 Hours

Professional installation recommended

SKILL LEVEL



4= Experienced

TOOLS REQUIRED

- Safety goggles
- Measuring tape
- Flat blade screwdriver
- Right angle drill
- 9/32" drill bit
- 17 mm socket
- 15 mm socket
- 10 mm socket
- T 15 Torx driver
- Ratchet wrench and extension
- Pliers
- Wire crimpers
- Wire stripper / cutter
- 3/16" hex key wrench (allen wrench)
- 4mm hex key wrench (allen wrench)
- Electrical tape
- Weather proof caulking (silicone sealer)

WARRANTY

5-Year Limited Warranty

AMP RESEARCH TECH SUPPORT 1-888-983-2204 (Press 2) Monday - Friday, 6:00 AM - 5:00 PM PST

Invented, engineered and manufactured exclusively by AMP Research in the USA. May be covered by one of the following patents: 6,641,158; 6,830,257; 6,834,875; 6,938,909; 7,055,839; 7,380,807; 7,398,985; 7,584,975 ©2012 AMP Research. All rights reserved. Printed in USA.

Purpose: Due to vehicle-build variations the Power Step may not correctly align with vehicle cladding. Using supplied shims, please follow the instructions below to correct the alignment.

Misalignment:	Shim Correction:
The gap between board and vehicle cladding is too large toward rear of running board.	Shim rear mount at lower bolt. (diagram below)
The gap between board and vehicle cladding is too small toward rear of running board.	Shim rear mount at upper bolt. (diagram below)
The gap between board and vehicle cladding is too large toward front end of running board.	Shim front mount at lower bolt. (diagram below)
The gap between board and vehicle cladding is too small toward front end of running board.	Shim front mount at upper bolt. (diagram below)

Shim Placement: Place shim(s) **ONLY WHERE NEEDED** as indicated above in “Misalignment/ Shim Correction” chart.

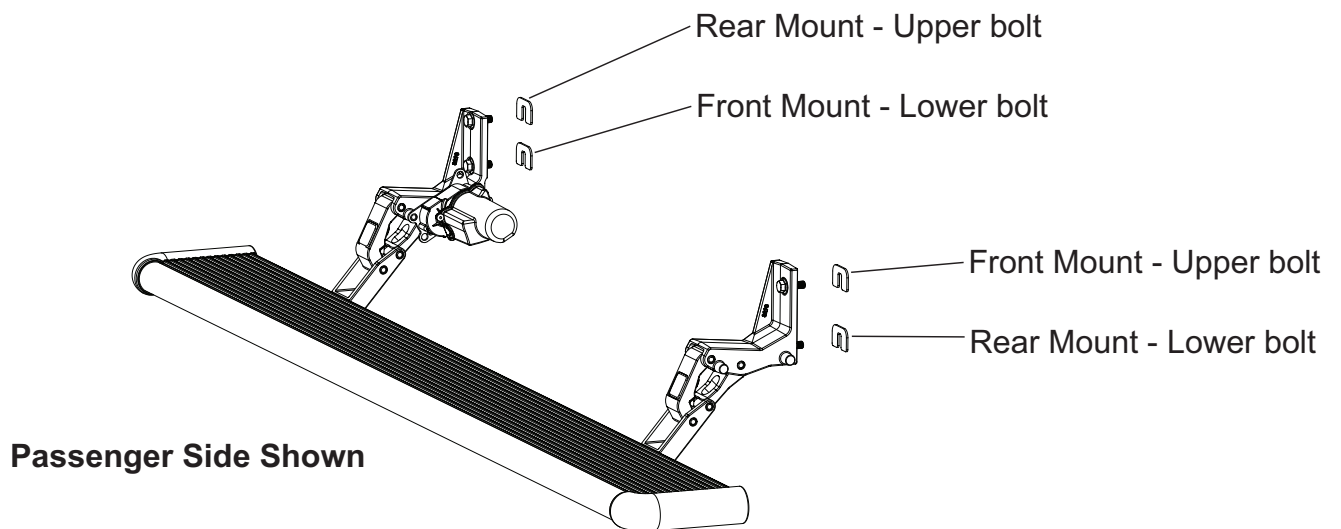

PARTS LIST AND HARDWARE IDENTIFICATION

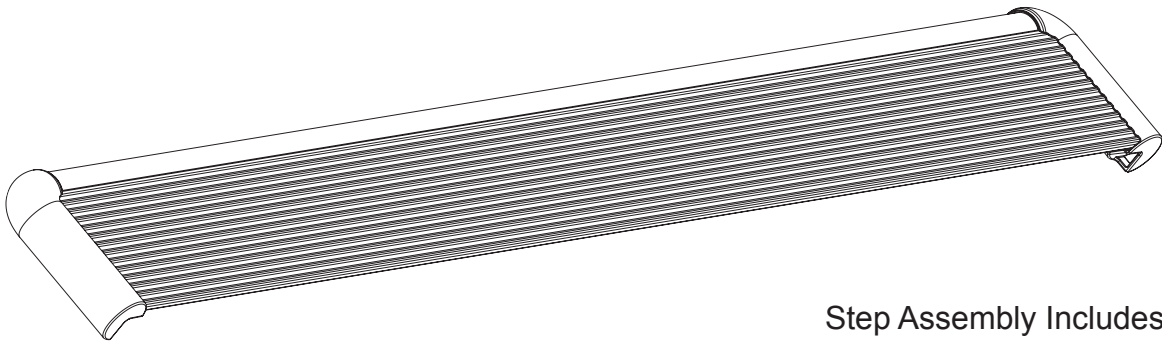

① x2
Step Assembly

Step Assembly Includes:
Endcap Left (x1)
Endcap Right (x1)
T-Nut Insert (x2)
Rivet (x2)

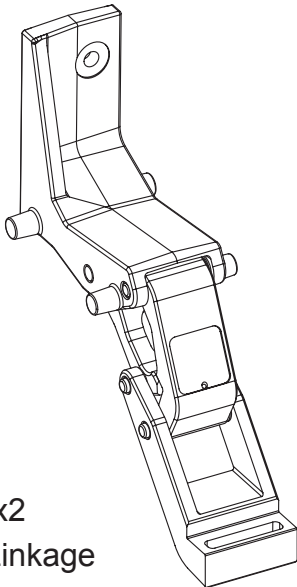

② x2
Idler Linkage

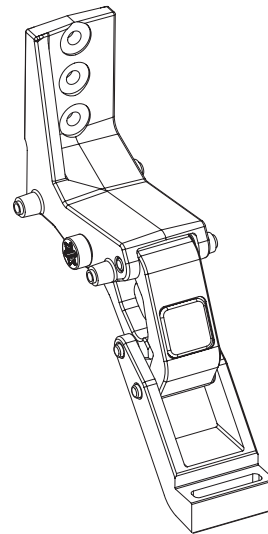

③
Motor Linkage Driver Side (1)
Motor Linkage Passenger Side (1)

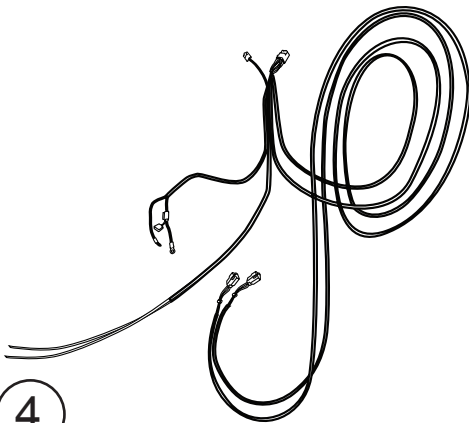

④
Wire Harness

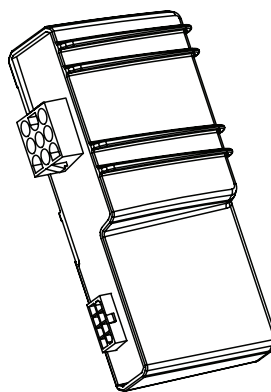

⑤
Controller STA

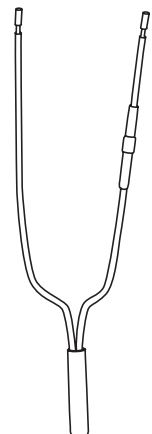

⑥ x4
Single Diode

PARTS LIST AND
HARDWARE
IDENTIFICATION

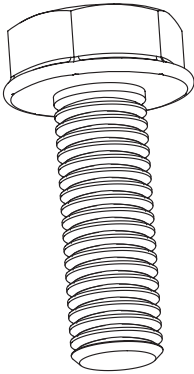

7 x8
Hex Flange Bolt

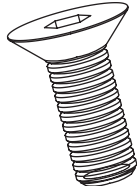

8 x4
Flat Head Cap Screw

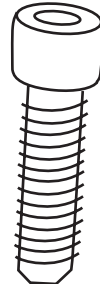

9 x8
Socket Cap Screw

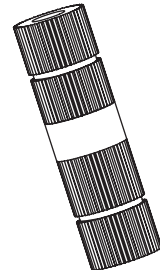

10
Posi-Tap™ (Red/Grey)

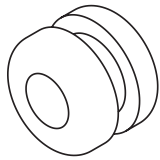

11
Grommet



12 x6
Cinch Fastener

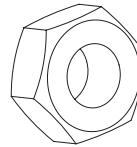

13 x2
Hex Nut



14 Includes x4
Shim



15 x20
Cable Tie 7"

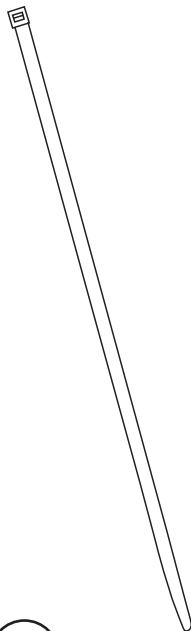

16 x2
Cable Tie 11"

Base Plate

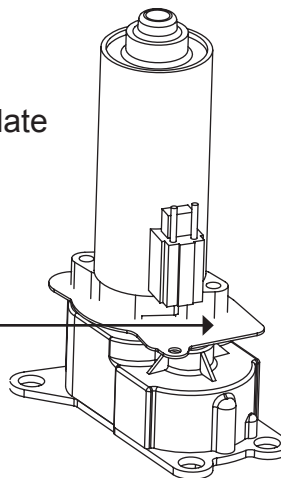

17 x2
Motor

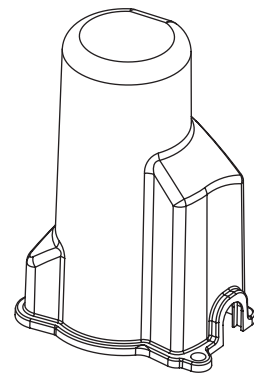

18 x2
Motor Cover

Remove existing rock rails and steps from the vehicle.

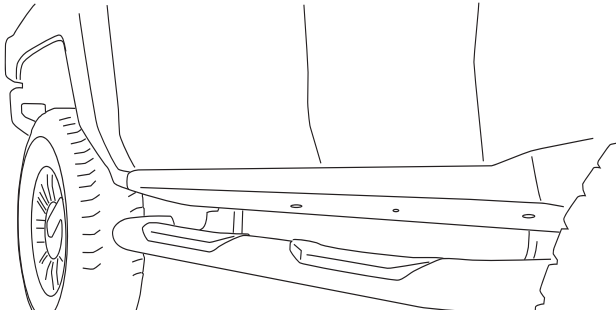

Step 2 for H3T ONLY

1

H3T ONLY

Skip steps 3 - 5

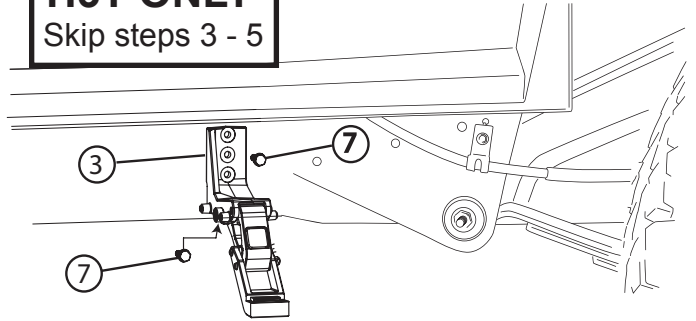

Mount motor linkage to frame on driver and passenger side with M10 flange bolts. Finger tighten bolts. Use middle hole on top and slotted hole on bottom. Drive shaft should face front. See close up below in step 4

2

SUV ONLY Unbolt emergency brake cable bracket. Cable needs to be on the outside of linkage

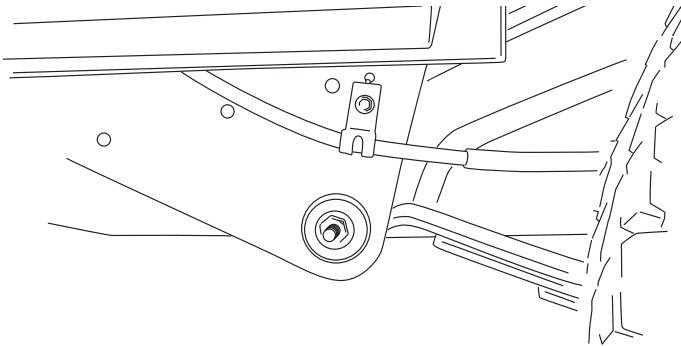

3

Mount drive and passenger motor linkage assembly to frame using supplied M10x30 flange bolts. Drive shaft should be facing front of vehicle. Finger tighten bolts.

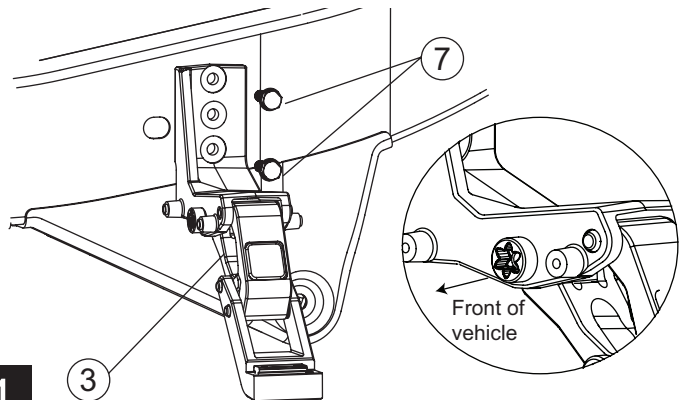

4

Bolt up emergency brake cable bracket. Torque bolts to 6ft-lbs(8N-m)

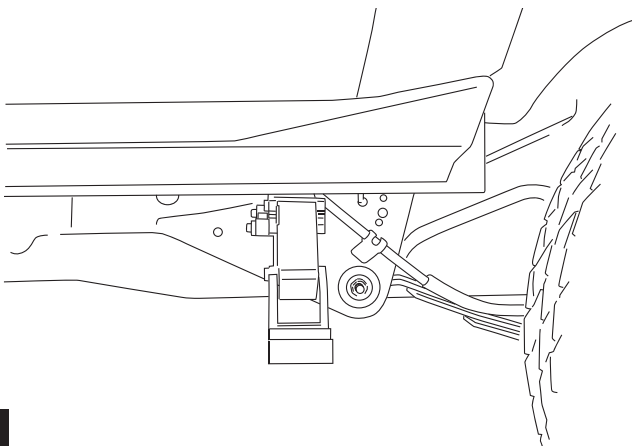

5

Mount idler linkage assemblies on driver and passenger side to forward frame locations with M10 flange bolts. Finger tighten bolts.

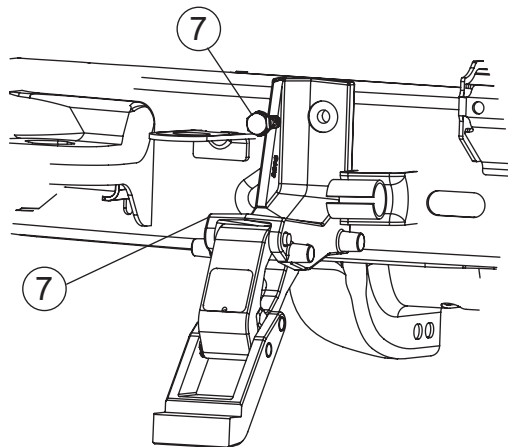

6

To mount running boards, slide T-nuts into position (Align with mounting holes).

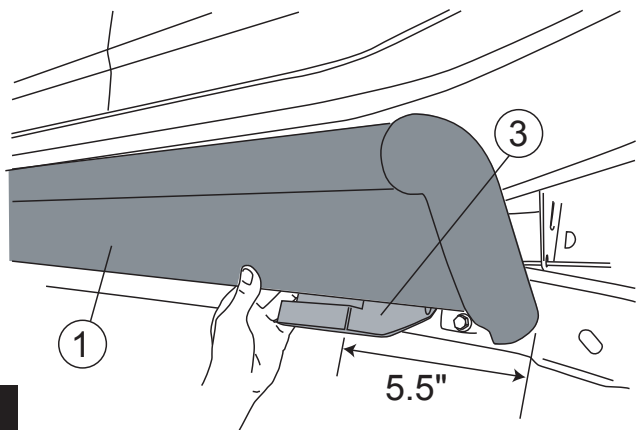

7

Tighten 4 bolts with 3/16" Allen wrench.
Torque bolts to 10ft-lbs. (13.5 Nm)

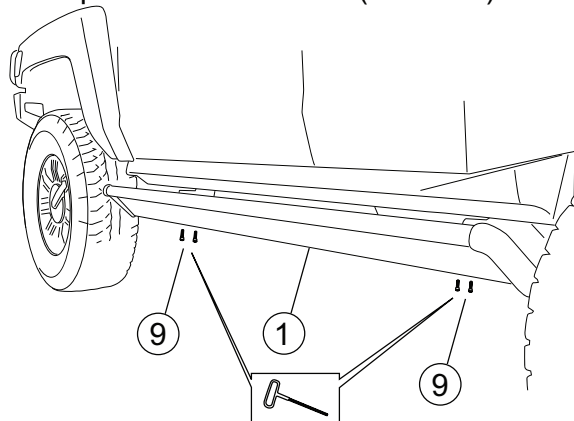

8

Torque linkage bolts to 40ft-lbs(54N-m)

Remove power fuse. Using supplied M6 nuts, attach power lead (RED) wire to positive terminal on battery. Attach ground lead (BLACK) to negative terminal on battery.

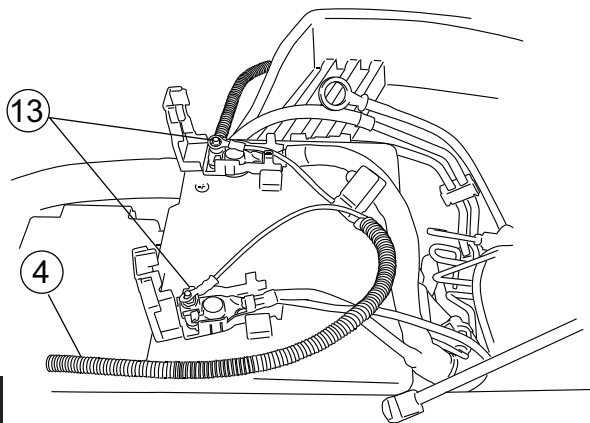

9

Mount controller to factory conduit using the two 11" cable ties.

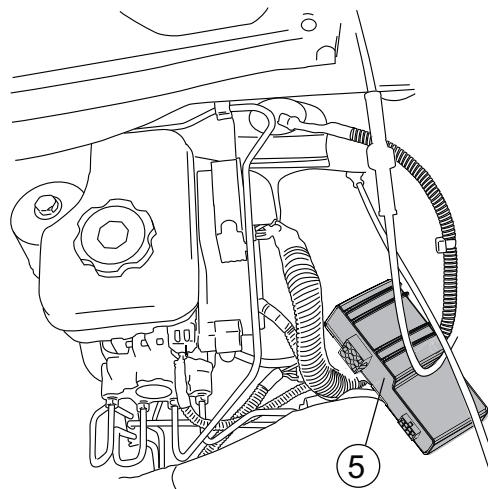

10

Route long end of wire harness across engine firewall and down through passenger wheel well. Route short end down drivers side wheel well. Use 7" cable ties to secure harness.

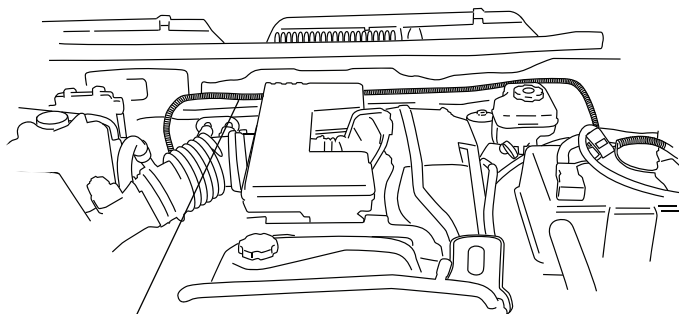

11

4

Route the wire harness along the frame, securing with cable ties. On passengers side route along outside of frame to avoid exhaust pipe.

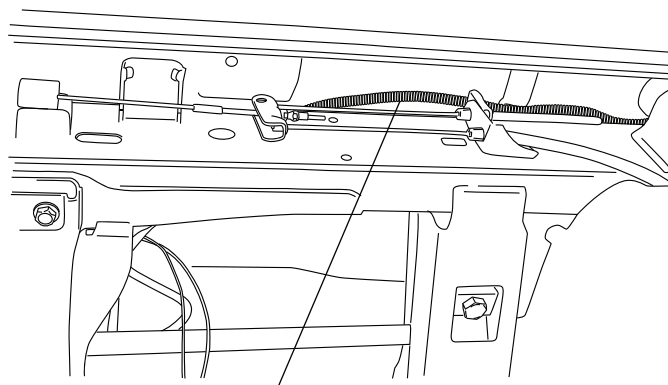

12

4

Repeat steps 7-12 on passengers side
 Insert plug from wire harness onto motor.

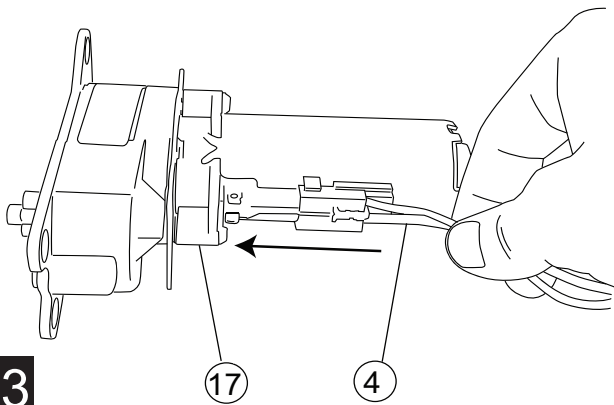

Slide rubber grommet on wire harness into slot of motor cover. Insert motor cover onto motor.

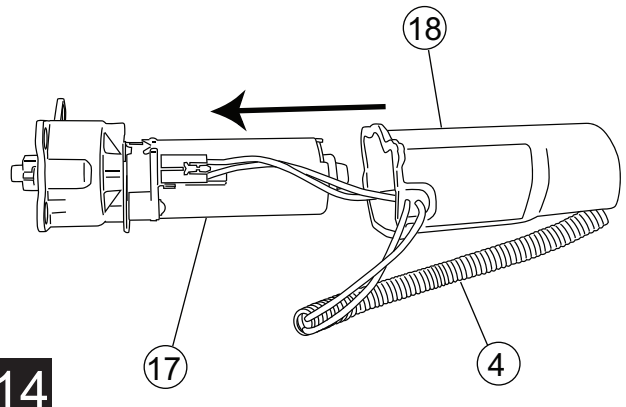

Insert plastic push pin rivets in mounting holes of motor cover.

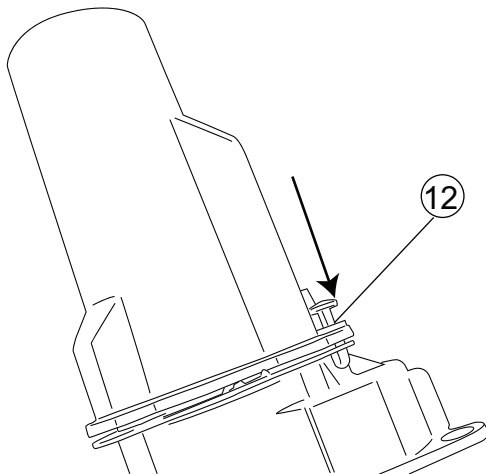

Install motor onto motor linkage assembly. Using two M6x16 Flat head screws to bolt linkage assembly.

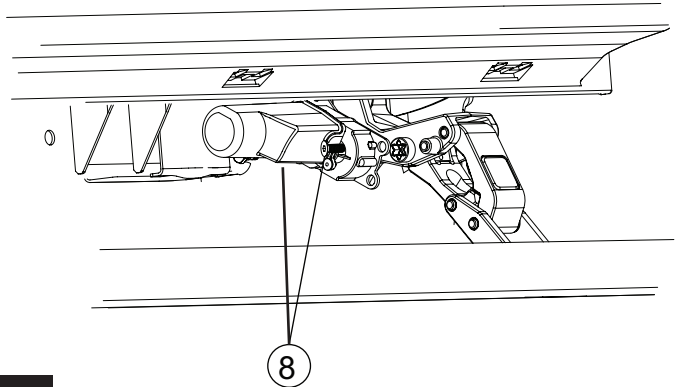

Repeat steps 7-16 on passengers side
 On drivers side; poke hole through rubber grommet near front door on underside of the floor pan with a philips screwdriver. Be careful not to go through carpet on other side.

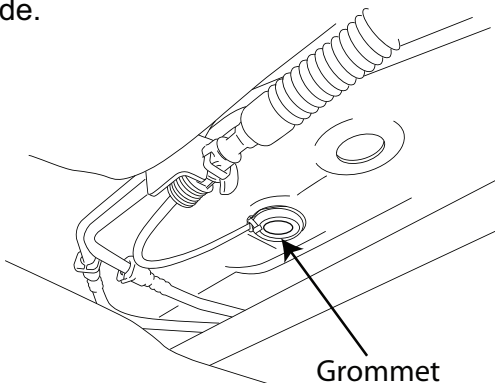

Feed trigger wires through hole

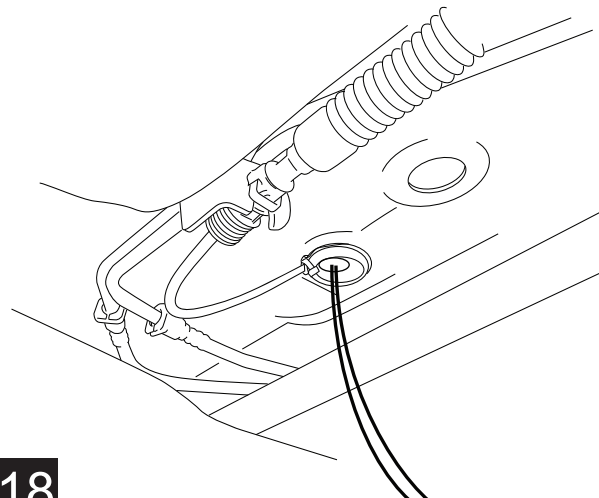

Carefully pull off the front threshold cover. It might be necessary to gently pry it off with a screwdriver.

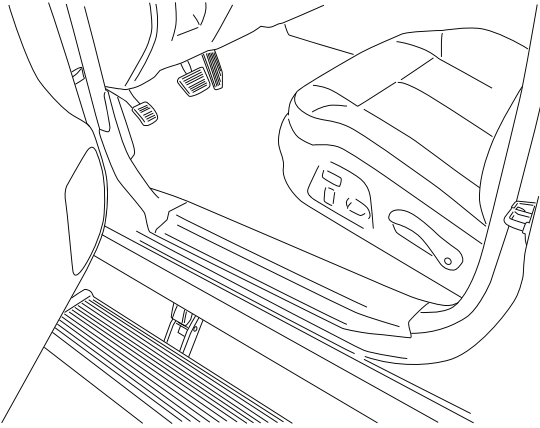

19

Carefully pull off the rear threshold cover. It might be necessary to gently pry it off with a screwdriver.

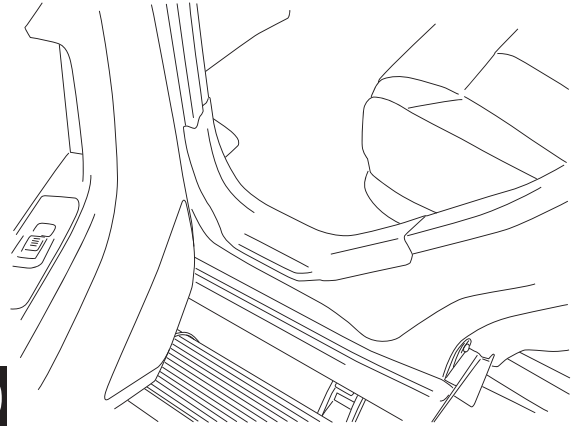

20

Pull up drivers side carpet and thread trigger wires through the floor. Seal wire and grommet with silicone sealer. Cover with tape to prevent sticking to carpet.

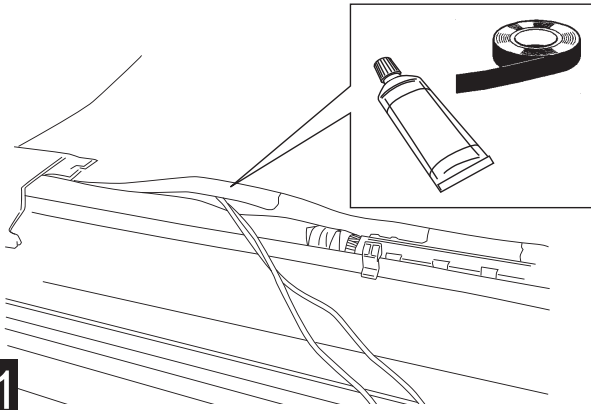

21

Posi-Tap™ instructions

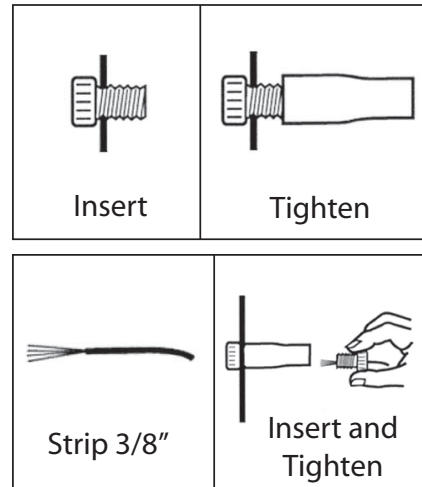

22

Locate factory wire harness going up B-pillar between doors on the driver side. Separate wires and locate the gray with black stripe wire. Using supplied Posi-Tap connector splice grey with black Power Step trigger wire to the grey with black stripe factory wire.

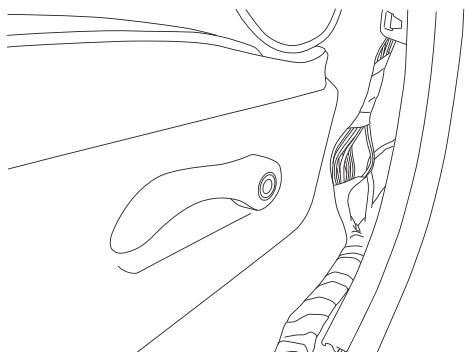

23

Locate the harness going up underneath the rear threshold cover. Pull wires apart to find the black with white stripe door ajar wire.

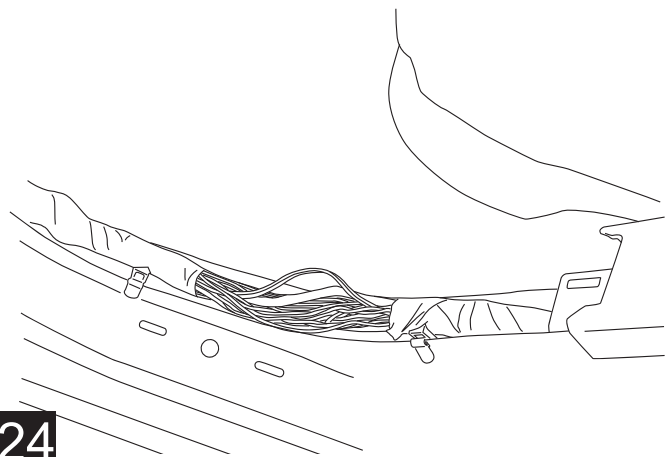

24

Using a test light, multi-meter or circuit tester determine if wire grounds when door is opened. There will be more than one wire that has black with white stripes that is constantly grounded; these are the incorrect wires.

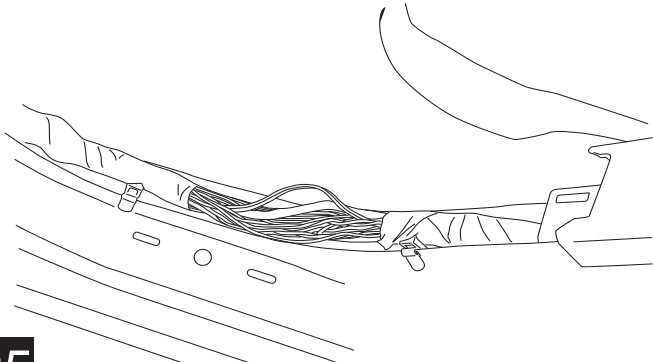

25

Attach single diode harness to black with white stripe trigger wire. Make sure diode is on side facing front of vehicle.

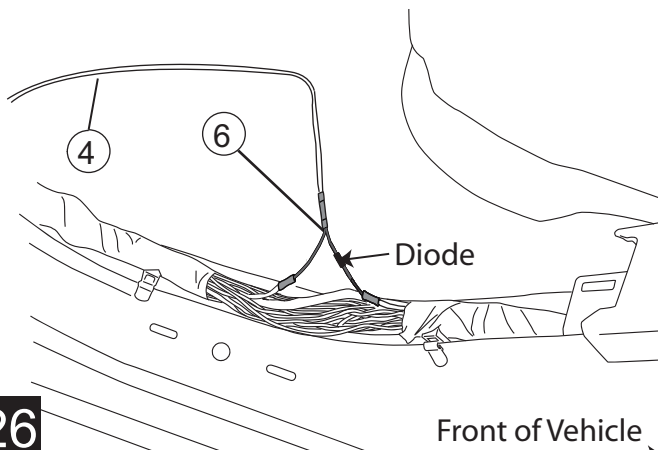

26

Front of Vehicle

Passengers side steps 20-28

Remove front and rear threshold covers. Move factory wire harness out of the way at front door.

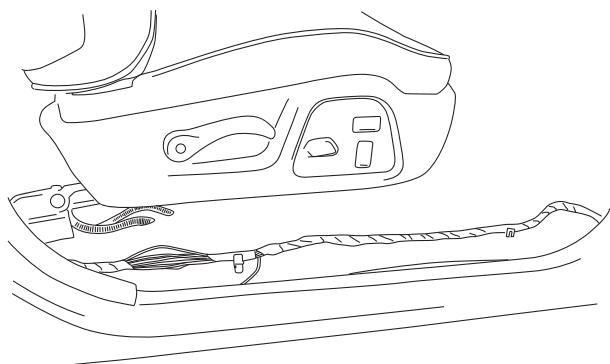

27

Drill a 9/32 hole in floorboard (see figure below). Be careful not to drill through carpet or wire harness on other side of floor pan.

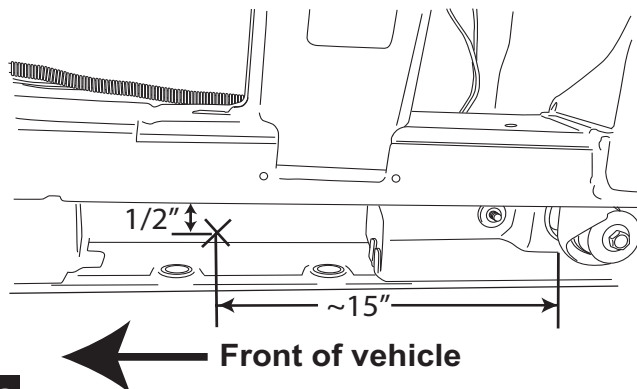

28

Front of vehicle

Install rubber grommet into hole and feed trigger wires through the grommet. Seal grommet with silicone and cover with tape to prevent it sticking to carpet.

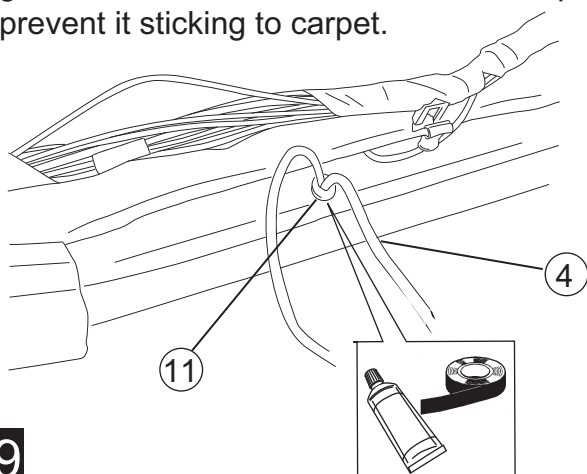

29

At front door locate green with black stripe door ajar wire in factory harness.

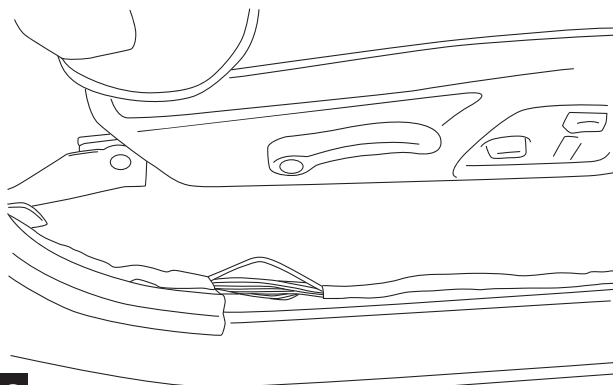

30

Attach single diode harness to green with black stripe trigger wire. Make sure diode is on side facing front of vehicle.

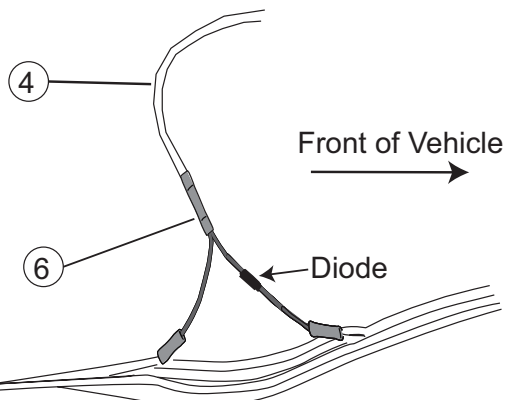

31

At passenger rear door locate the blue with black stripe wire(s) under the threshold cover. H3T will only have one blue with black stripe wire. Install a single diode harness as shown in step 33 then go to step 36.

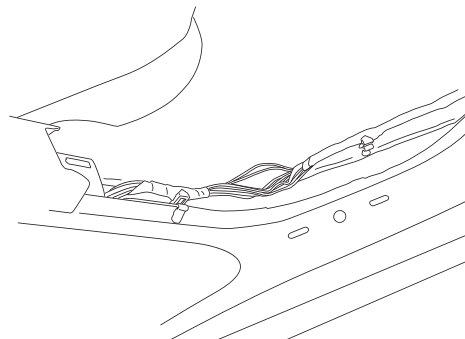

32

Attach single diode harness to each wire. Make sure diode is on side facing front of vehicle.

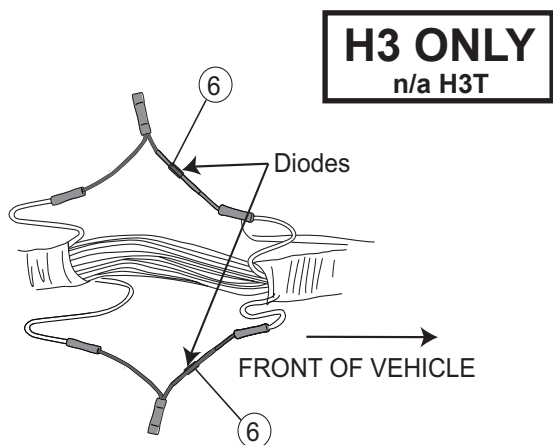

33

Remove rear passengers pin switch in door frame.

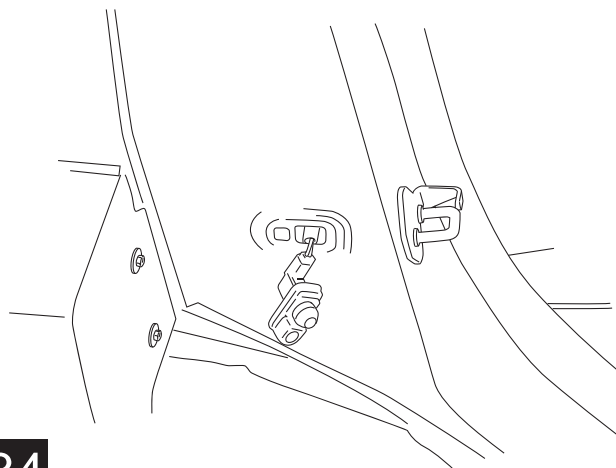

34

Determine which wire is from pin switch using a multi-meter or circuit tester. One wire will be for the rear hatch and one for the pin switch. Connect blue with back stripe trigger wire to the door pin wire.

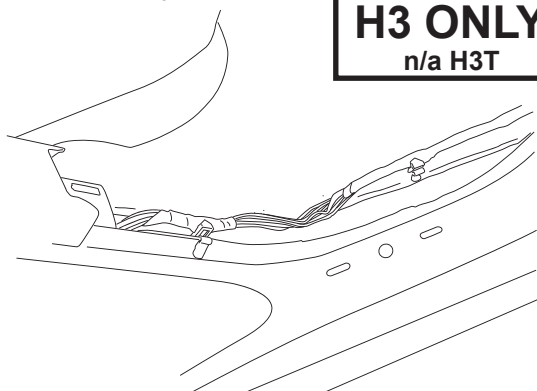

H3 ONLY
n/a H3T

35

Reinstall fuse and check for proper operation by opening and closing all doors.

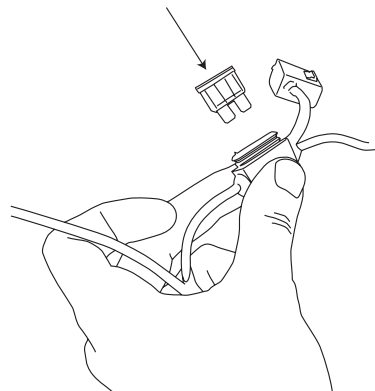

36

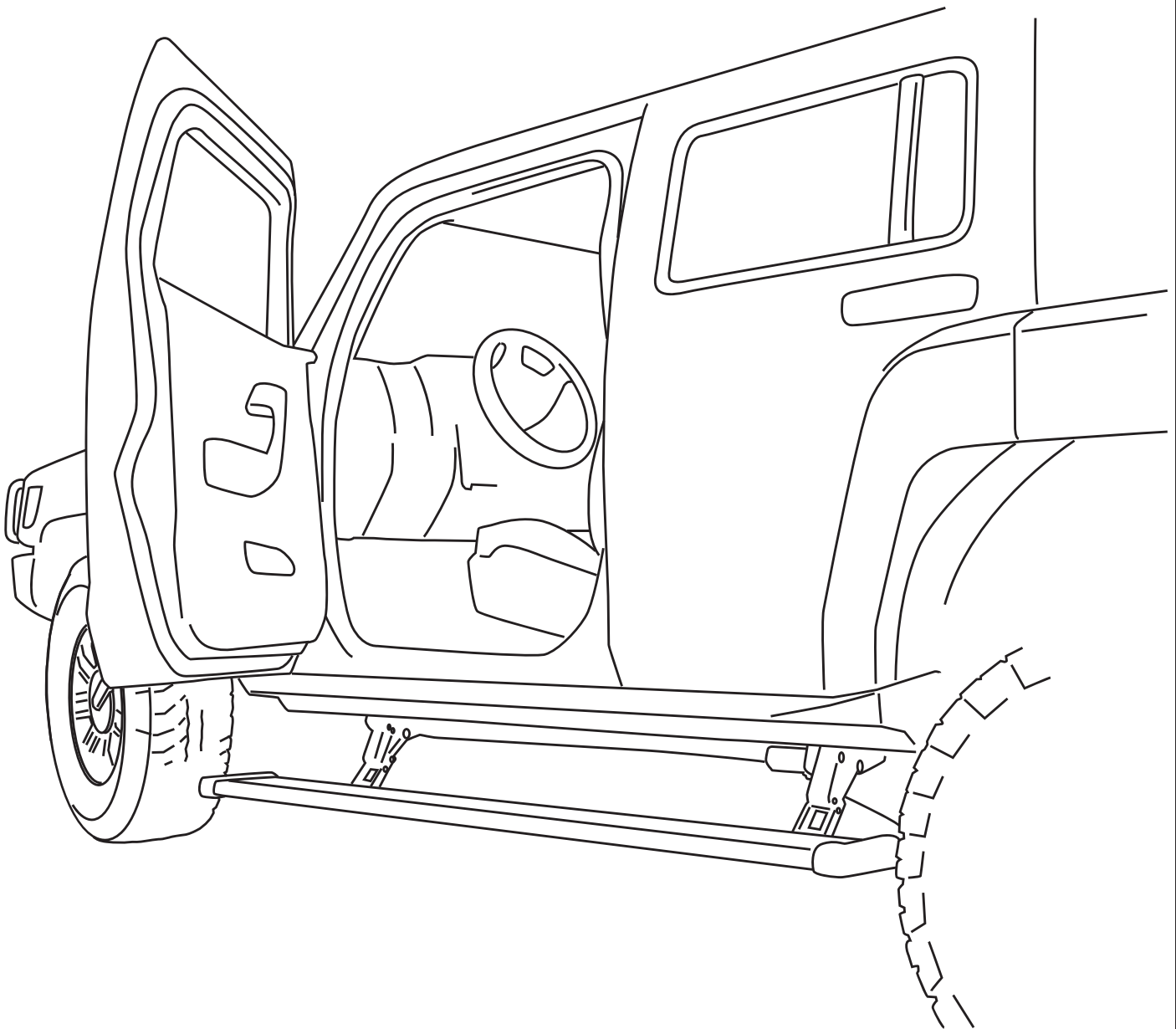
**FINAL SYSTEM CHECK**

Check that all doors activate the PowerStep and the LED lights work when doors open and close.

NORMAL OPERATION: When the doors open, PowerStep automatically deploys from under the vehicle. When the doors are closed, PowerStep will automatically return to the stowed/retracted position. **Note that there is a 2-second delay before the PowerStep returns to the stowed/retracted position.**

CORRECT OPERATION OF LIGHTS: All four lamps will illuminate upon opening any door of vehicle. Lamps will stay on until restowing of both Power Steps or until 5 minutes has expired with the doors open. When the lights timeout after 5 minutes, they can be reilluminated by closing and opening any door of vehicle.

POWER-DEPLOYABLE RUNNING BOARDS OPERATION: AMP Research PowerStep running boards automatically move when the doors are opened to assist entering and exiting the vehicle.

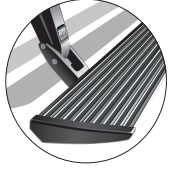

Automatic power deploy:

The running boards will extend down and out when the doors are opened.

Automatic power stow:

The running boards will return to the stowed position when the doors are closed. There will be a 2-second delay before the running boards move to the stowed position.

Automatic stop:

If an object is in the way of the moving running board, the running board will automatically stop. To reset, clear any obstruction, then simply open and close the door to resume normal operation.



Manually set in the deployed (OUT) position for access to the roof:

The running boards can be manually set in the deployed position by firmly holding the step down with your foot while at the same time closing the door. To resume normal operation, open and close the door.

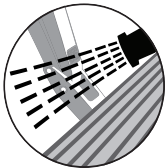

Maintenance: In adverse conditions, debris such as mud, dirt, and salt may become trapped in the running board mechanism, possibly leading to unwanted noise. If this occurs, manually set the running boards to the deployed position and flush the front and rear hinge arms with a high-pressure car wash wand. Avoid spraying the motors directly. After washing, apply silicone spray lubricant to the hinge pivot pins. Do not apply silicone, wax or protectants like Armor All® to the running board stepping surface.

Caution! Keep hands away when the running board is in motion.

5-YEAR LIMITED WARRANTY

AMP RESEARCH warrants this product to be free from defects in material and workmanship for FIVE (5) YEARS FROM DATE OF PURCHASE, provided there has been normal use and proper maintenance. This warranty applies to the original purchaser only. All remedies under this warranty are limited to the repair replacement of the product itself, or the repair or replacement of any component part thereof, found by the factory to be defective within the time period specified. The decision to repair or replace is wholly within the discretion of the manufacturer.

This warranty specifically excludes labor. If you have a warranty claim, first you must call our factory at the number below for instructions. You must retain proof of purchase and submit a copy with any items returned for warranty work. Upon completion of warranty work, if any, we will return the repaired or replaced item or items to you freight prepaid. Damage to our products caused by accidents, fire, vandalism, negligence, misinstallation, misuse, Acts of God, or by defective parts not manufactured by us, is not covered under this warranty.

ANY IMPLIED WARRANTIES OF MERCHANTABILITY AND/OR FITNESS FOR A PARTICULAR PURPOSE CREATED HEREBY ARE LIMITED IN DURATION TO THE SAME DURATION AND SCOPE AS THE EXPRESS WRITTEN WARRANTY. OUR COMPANY SHALL NOT BE LIABLE FOR ANY INCIDENTAL OR CONSEQUENTIAL DAMAGE.

Some states do not allow limitations on how long an implied warranty lasts, or the exclusion or limitation of incidental or consequential damages, so the above limitations or exclusions may not apply to you. This warranty gives you specific legal rights, and you may also have other rights that vary from state to state.

FOR WARRANTY ISSUES WITH THIS PRODUCT PLEASE CALL AMP RESEARCH CUSTOMER SERVICE 1-888-983-2204

WARNING

Be sure to read and precisely follow the provided instructions when installing this product. Failure to do so could place the vehicle occupants in a potentially dangerous situation. After installing or reinstalling, re-check to insure that the product is properly installed.