

INSTALLATION INSTRUCTIONS

EGR *ROLLTRAC*

MANUAL

Vehicle Model: CHEVROLET SILVERADO 1500 (T1 XX)
5Ft/Short Bed LHD & RHD - Excludes models with accessories
that would affect EGR RollTrac fitment
Year of manufacture: MY 2019 onwards

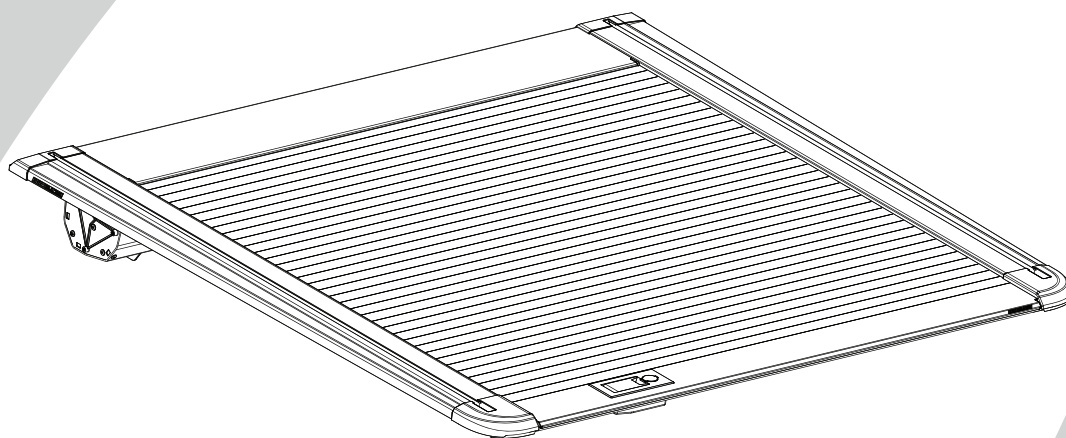

Installation time: 120 minutes

* Image shows LHD version, handle location may vary

Caution

- Do not attach EGR RollTrac in a location or by a method not specified.
- Do not use this product for any vehicle make or model, other than those specified in this document.
- Do not remove the plaque or label from this product.
- Do not modify the structure of the EGR RollTrac in any way.

General Notes

- Read through the fitting instructions before installation of EGR RollTrac.
- Always install the accessory following the fitting instructions. Failure to do so may cause damage to the vehicle or the accessory.
- Ensure all recyclable discarded vehicle accessory components and packaging are recycled following local recycling regulations.
- It is always recommended that this accessory is fitted by a qualified Technician.
- Safely store and protect any removed vehicle components.
- Ensure all bare metal surfaces are protected using Automotive Bare Metal Primer and touch-up paint.
- Remove all metal swarf and dust from all vehicle surfaces if surface is used for accessory installation.

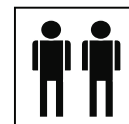

Safety Notes

- Check that all work practices comply with safety standards.
- Please wear appropriate clothing and use safety equipment.



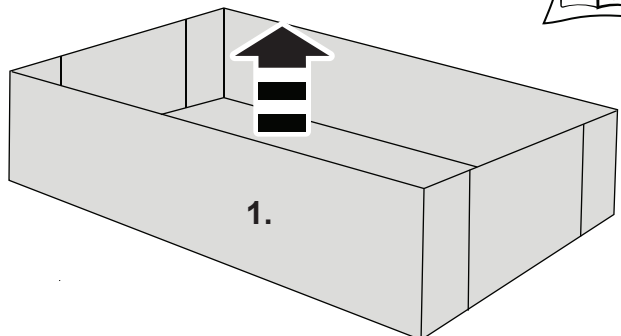
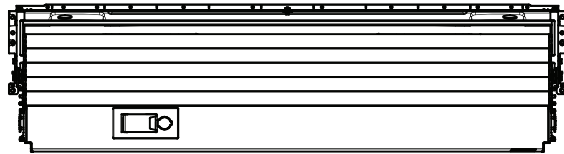
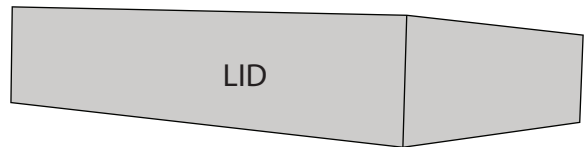
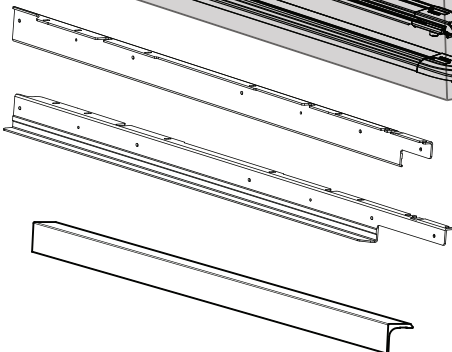
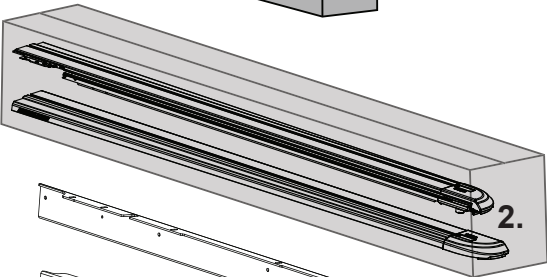
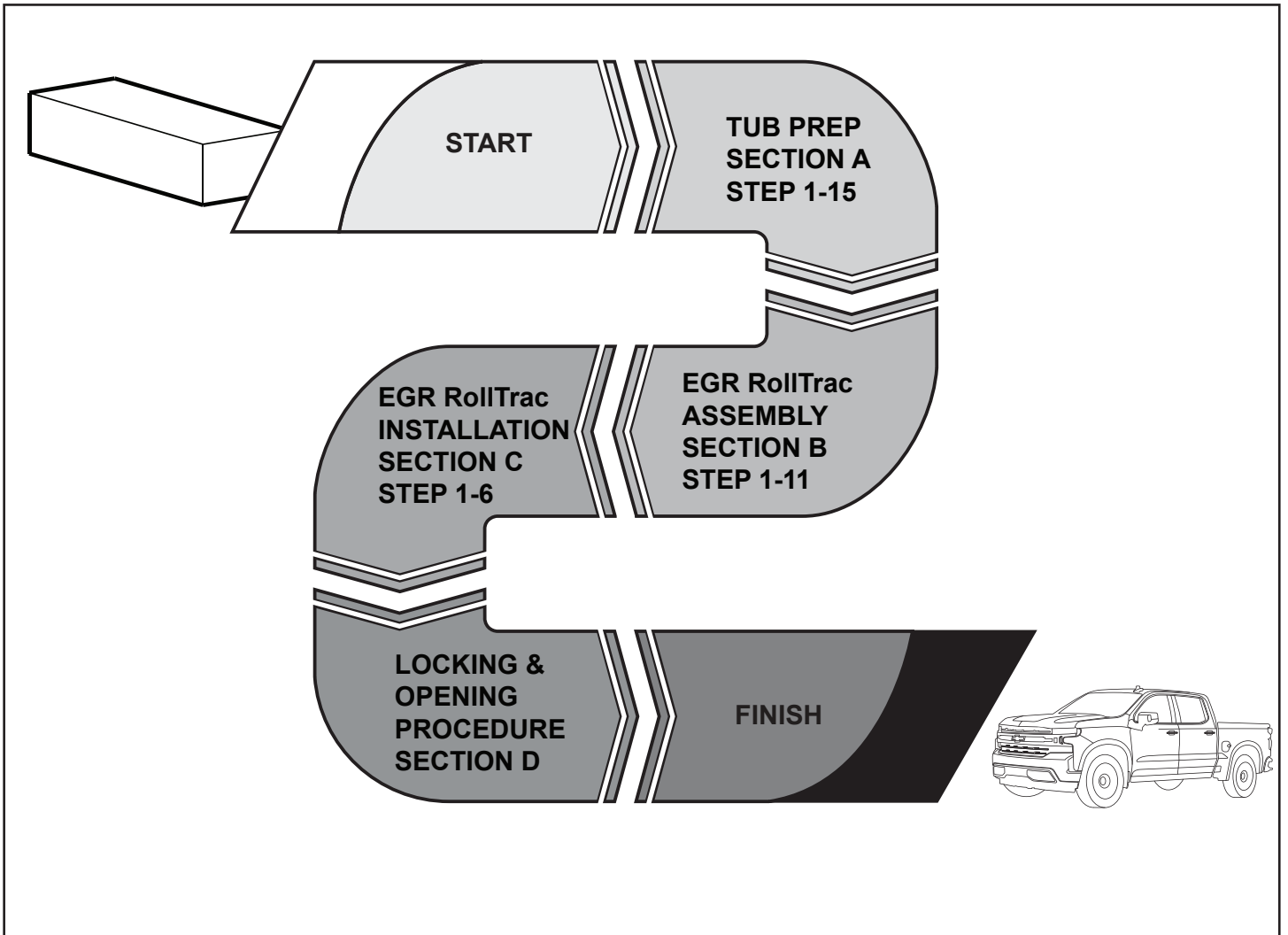

KIT CONTENTS - COMPONENT NUMBER AND QUANTITY

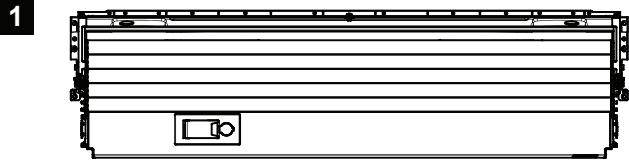

1
CANISTER ASM. QTY: 1

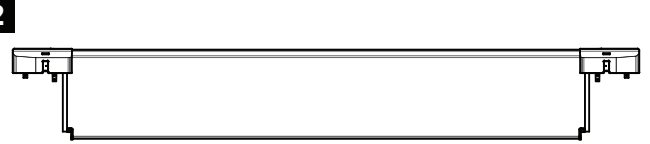

2
FRONT COVER QTY: 1



3
LHS RAIL QTY: 1

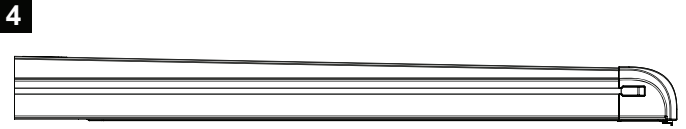

4
RHS RAIL QTY: 1

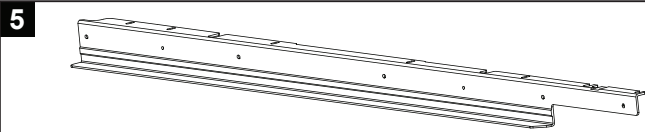

5
LHS MOUNT EXTRUSION QTY: 1

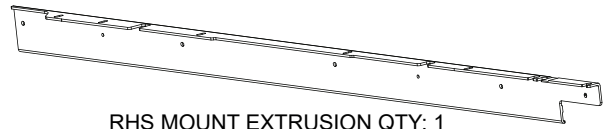

6
RHS MOUNT EXTRUSION QTY: 1

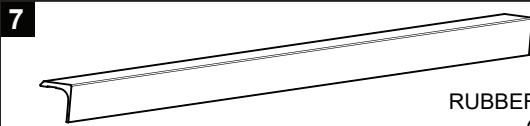

7
RUBBER EXTRUSION
QTY: 1

EGR RollTrac FITTING KIT IN BOX

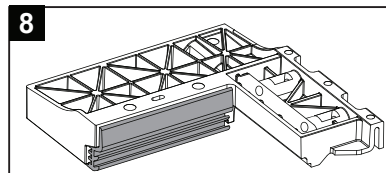

8
CANISTER STOP LH
QTY: 1

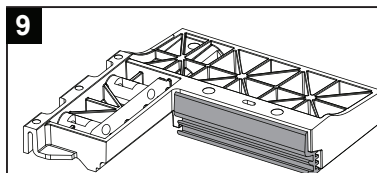

9
CANISTER STOP RH
QTY: 1

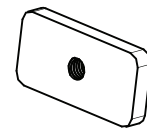

10
MISC5512PC
M6 TAPPED PLATE
QTY: 8



11
SCR0973 (BLACK)
SCREW M6X15MM
QTY: 8

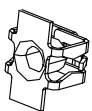

12
NUTS0293
M6 NUT CLIP
QTY: 2

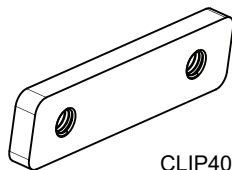

13
CLIP4038
M6 TAPPED PLATE
QTY: 2



14
SCR1033 (BLACK)
SCREW M6X35MM
QTY: 4

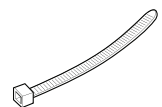

15
CONS70097
CABLE TIE
QTY: 10

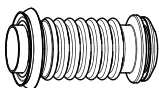

16
MISC5222
FRONT DRAINAGE TUBE
QTY: 2



17
KIT037458
REAR DRAINAGE TUBE KIT
QTY: 2

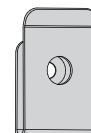

18
MISC4041
DRILL JIG
QTY: 1

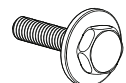

19
SCR0997 (BLACK)
SCREW M6x20
QTY: 12



20
SCR1001 (SILVER)
SCREW M6x15
QTY: 12

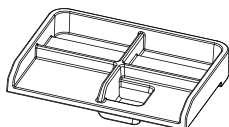

21
SETUP JIG
QTY: 2

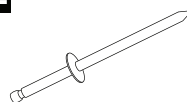

22
RIVET
FAST0441
QTY: 4

EGR RollTrac FITTING KIT ADDITIONAL ITEMS

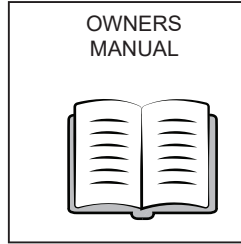
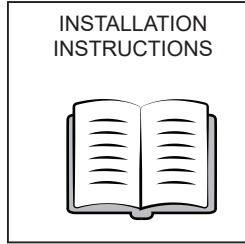
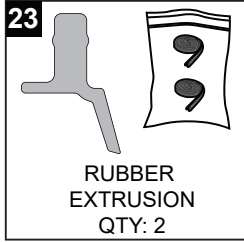

TOOLS REQUIRED - NOT SUPPLIED IN KIT

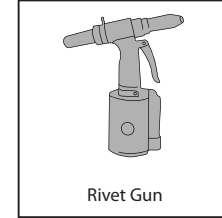
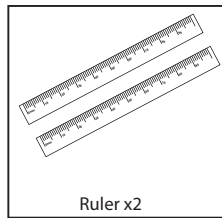
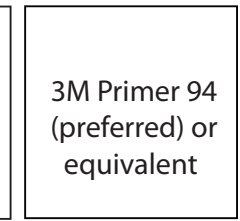
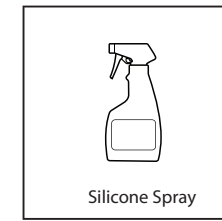
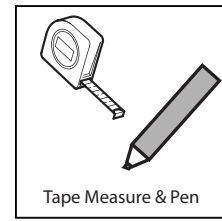
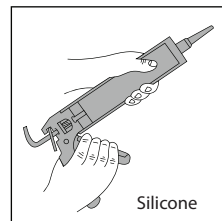
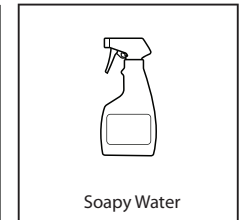
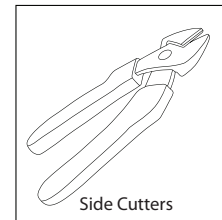
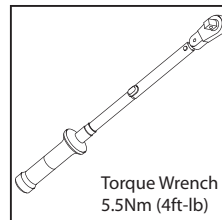
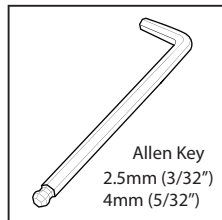
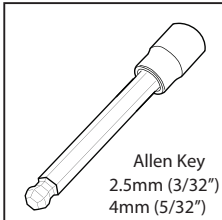
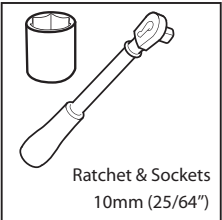
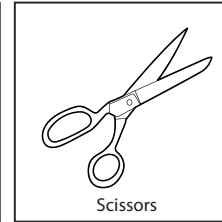
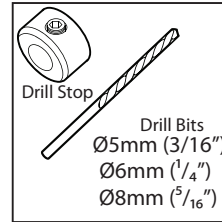
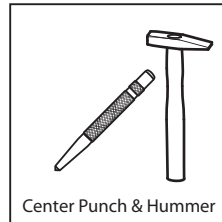
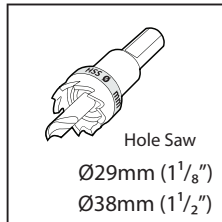
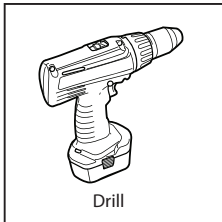

GLOSSARY:

- 1** Number inside a square indicate part number
- 1** Number inside circle indicate the sequence within a step
- 1** Number inside the hexagon indicate torque instruction

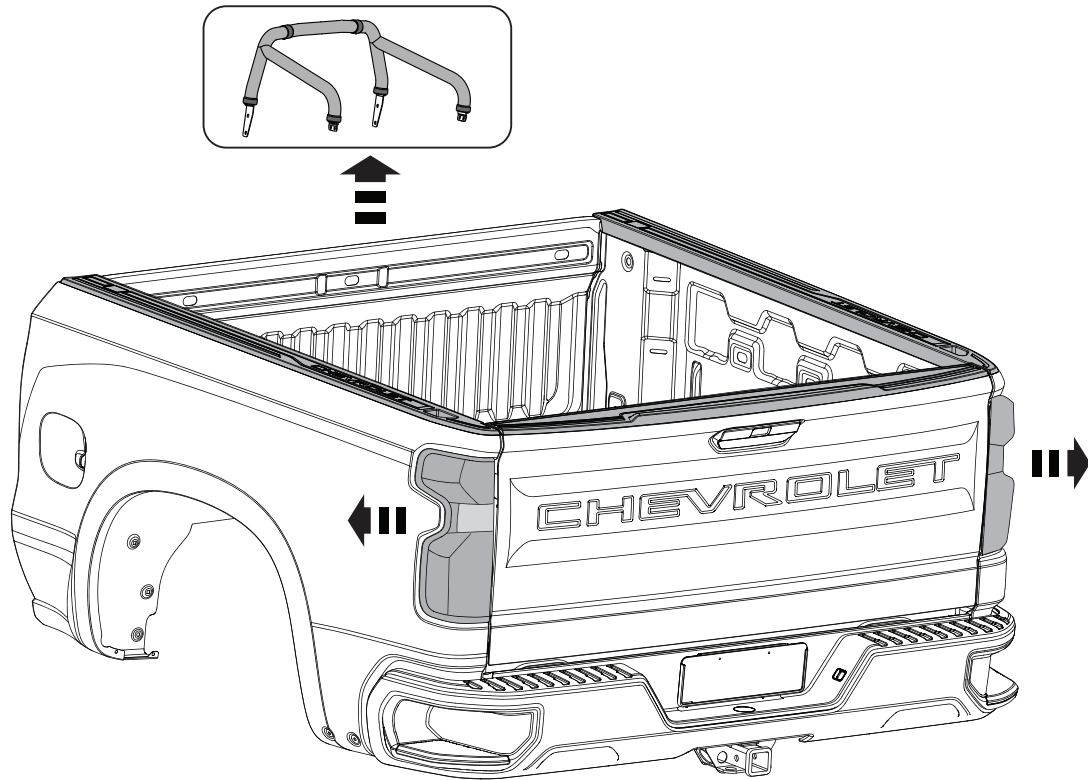

1 Carefully remove any accessories (Sports Bars, Cabin Guards, etc.) attached to the vehicle bed. Do not remove the bed rail caps and tailgate step handle if fitted. Thoroughly wash the vehicle and bed and ensure that all dirt and grease is removed. Allow to dry. Clean the top surfaces of the bed and tailgate and allow to dry. Carefully remove both Rear Tail Lamps with the appropriate tools and store in safe place. Retain all hardware for re-installation.

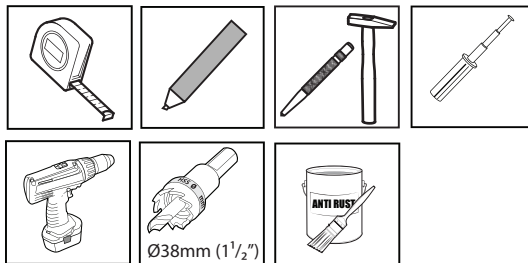

ATTENTION
 Repeat for LHS

ATTENTION Ensure that the diameter of the hole does not exceed Ø38mm (1 1/2")
 Larger hole size will lead to water ingress into the bed

INSTALL FRONT DRAIN TUBES TO BED

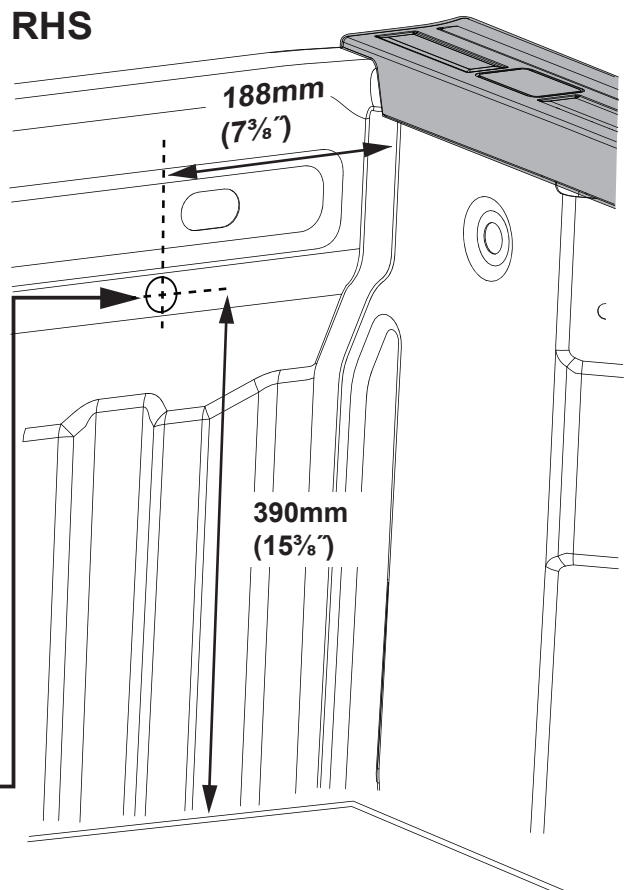
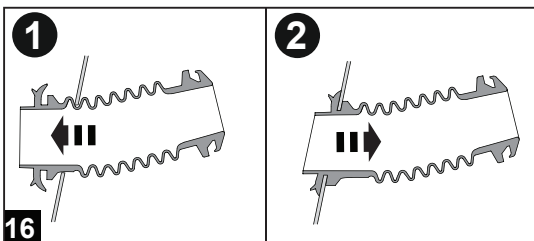

2 Mark the position for the front drain holes in the bed front panel, center punch and drill with Ø38mm (1 1/2") hole saw. RHS shown, repeat on the LHS. Clean all burrs and coat the exposed metal with a suitable rust preventative (not supplied). Fit front drain tubes (16) to the bed.

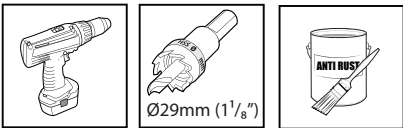
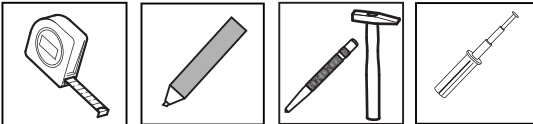

ATTENTION  Ensure that the diameter of the hole does not exceed $\text{Ø}29\text{mm}$ ($1\frac{1}{8}"$)
Larger hole size will lead to water ingress into the bed

ATTENTION  Repeat for RHS

LHS

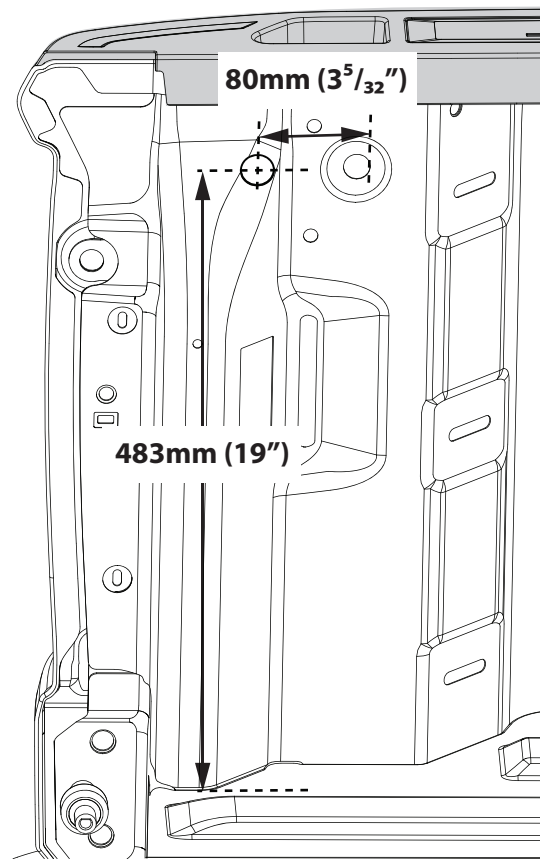

3 Mark the position of the rear drain tubes holes in the bed rear side panel, center punch and drill with $\text{Ø}29\text{mm}$ ($1\frac{1}{8}"$) hole saw. LHS shown, repeat on the RHS. Clean all burrs and coat the exposed metal with a suitable rust preventative (not supplied).

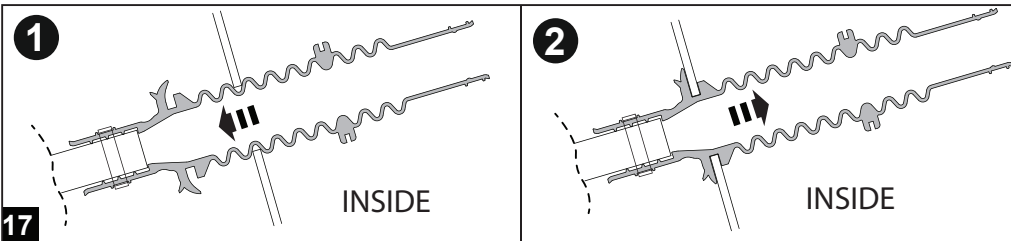

LHS

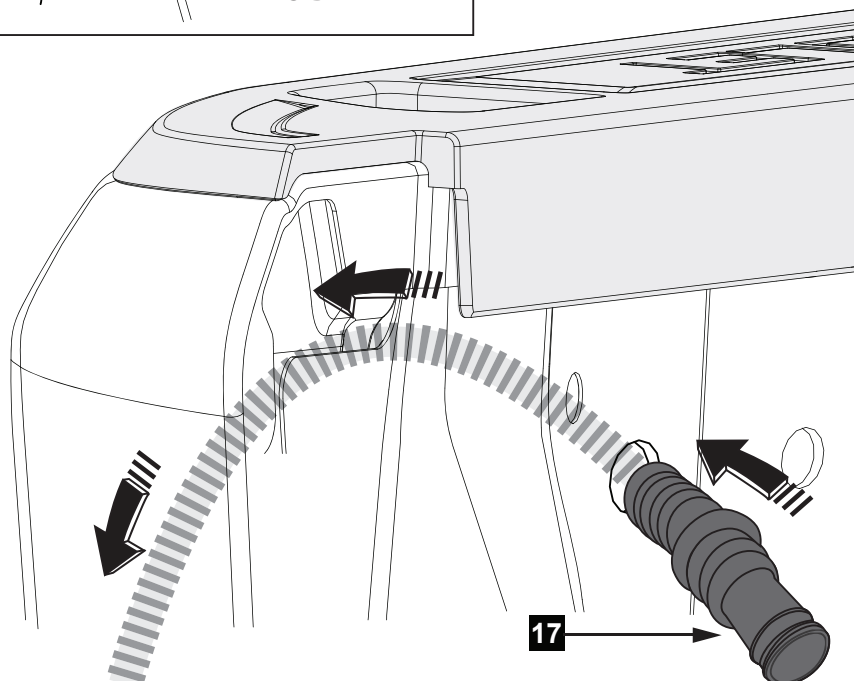

4 Feed the rear drain tube into the drilled hole. Guide the plastic tube inside the tail light cavity towards the ground. Push the rubber tube in until seated firmly in the hole, see detail view. Repeat for RHS.

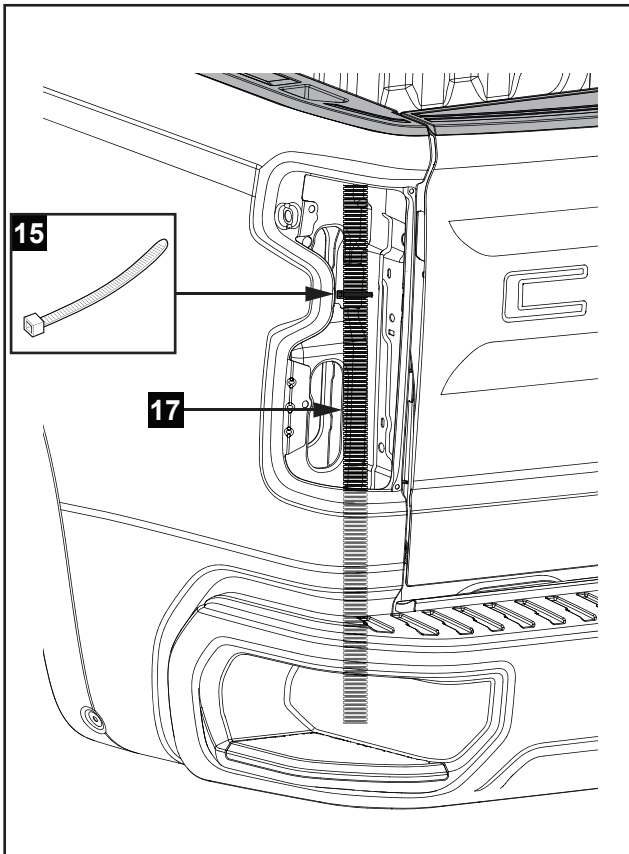

LHS & RHS

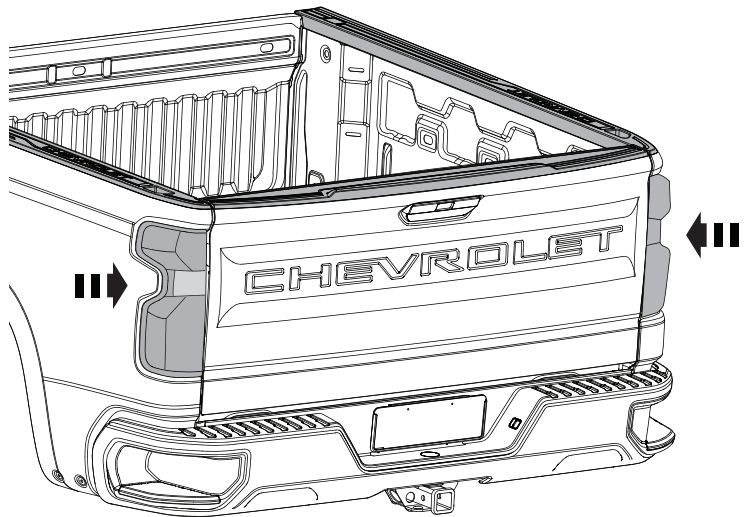

5 Secure the drain tube (17) to the sheet metal inside the tail light cavity using one cable tie (15) as shown. Refit the tail lights. Repeat for RHS.

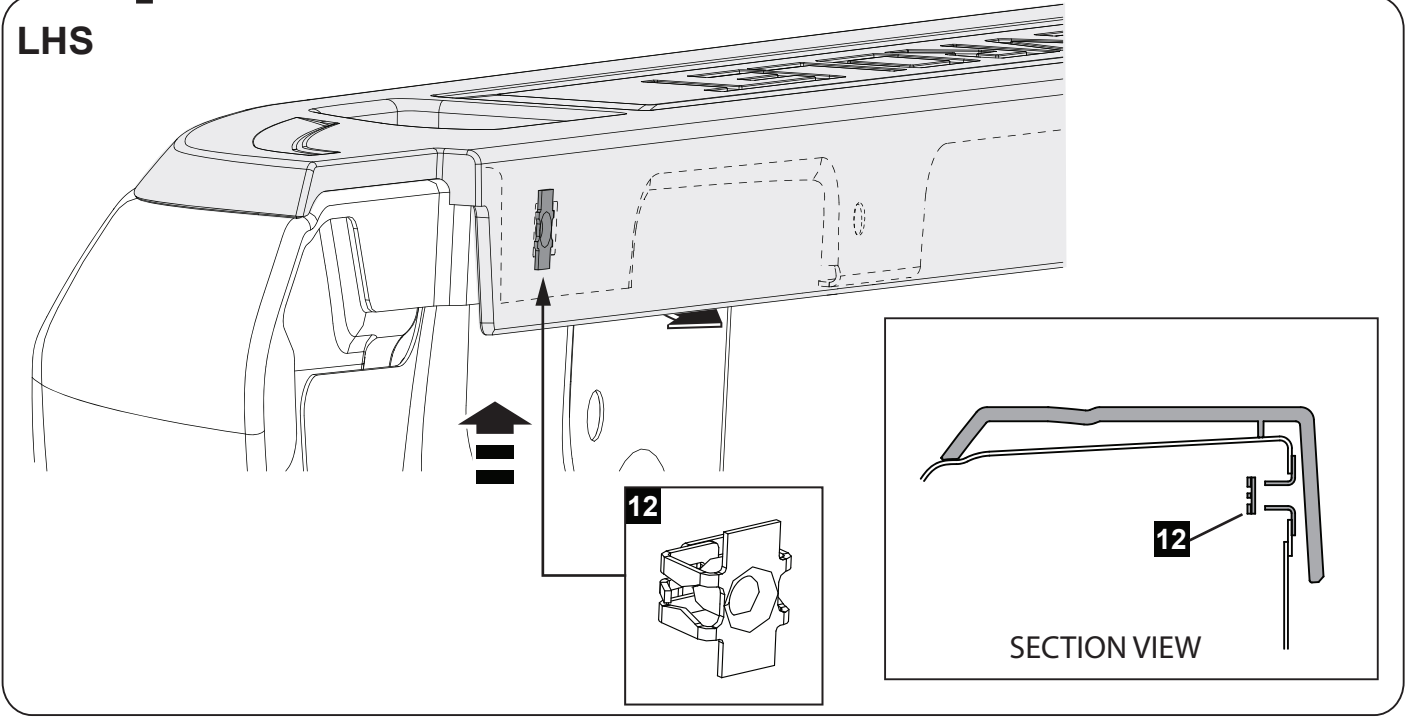
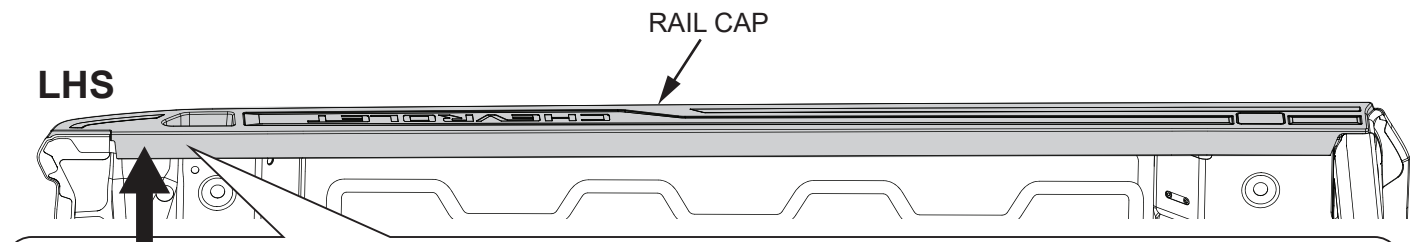

6 Lift the rail cap corner (rear LHS shown) and push in the M6 Nut Clip (12) into the square hole in the bed. Repeat for the RHS.



Ø6mm (1/4")

LHS

RAIL CAP

ATTENTION



USE DRILL JIG

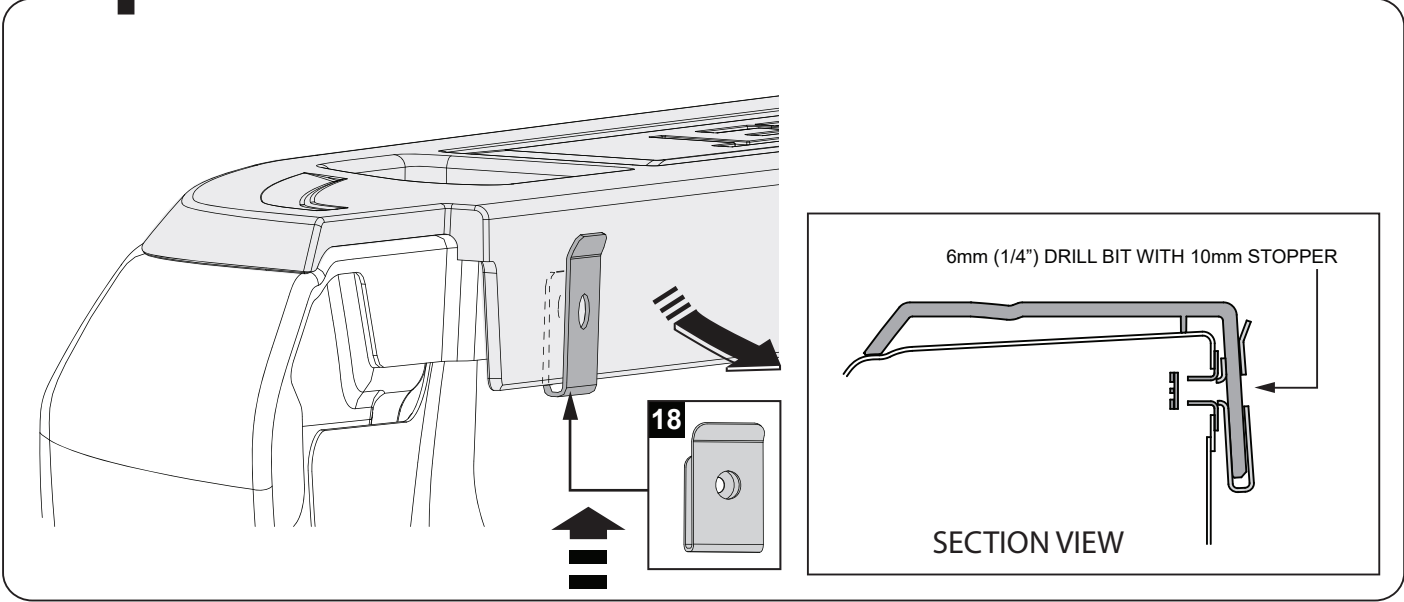
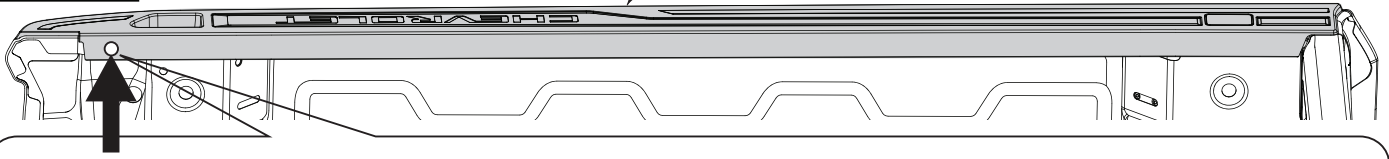

- 7** Lift the plastic rail cap and slide the drill jig (18) over the plastic only. Position the drill jig over the M6 Nut Clip and make sure the extruded hole on the jig locates into the hole in the nut clip before drilling. Drill a pilot hole using Ø6mm (1/4") drill bit through the plastic only. Remove the jig.

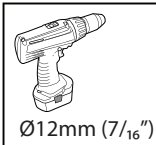

Ø12mm (7/16")

ATTENTION



USE DRILL JIG

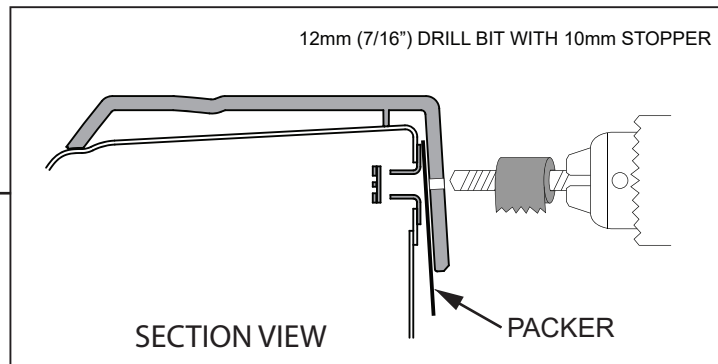
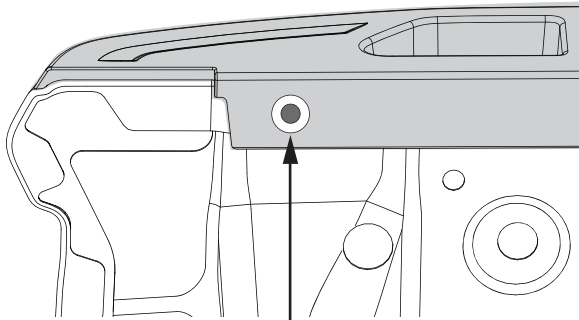

- 8** Using the pilot hole in bed cap (from step 7) as a guide, enlarge the hole with a 12mm (7/16") drill bit. DO NOT touch the sheet metal while drilling (the use of a drill stop and/or a packer to protect the nut clip is recommended). Ensure the hole in plastic clears the hole in nut clip.

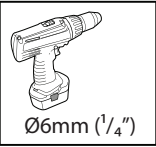

Ø6mm (1/4")

LHS

RAIL CAP

ATTENTION



USE DRILL JIG

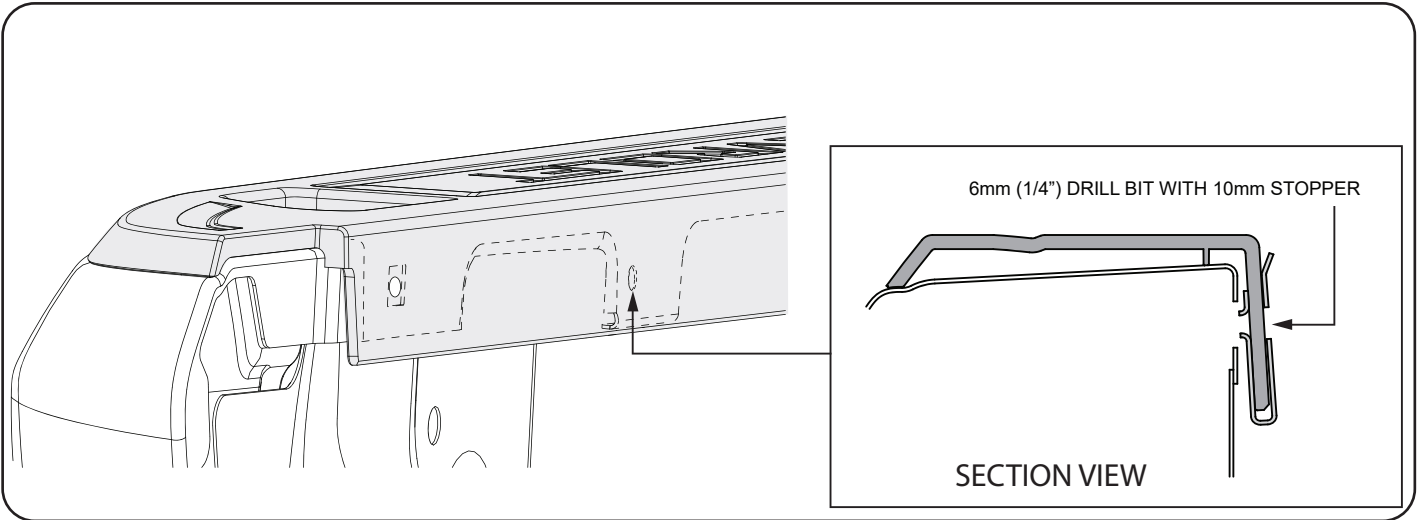
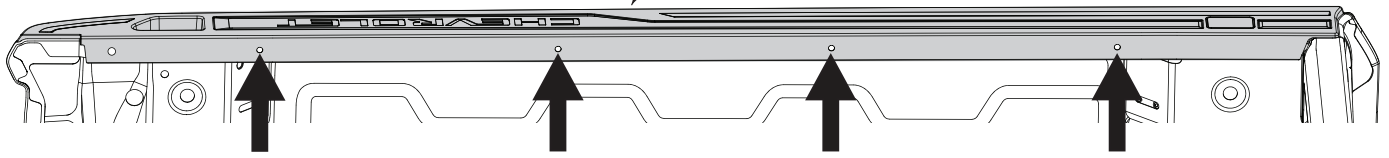

6mm (1/4") DRILL BIT WITH 10mm STOPPER

SECTION VIEW

- 9** Locate the 4 holes in the sheet metal. Slide the drill jig over the remaining 4 locations, locating the extruded hole centrally into existing hole, and drill a pilot hole using a Ø6mm (1/4") drill bit through the plastic only. Remove the jig.

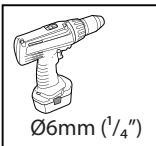

Ø6mm (1/4")

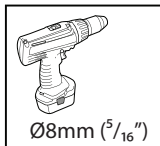

Ø8mm (5/16")

RAIL CAP

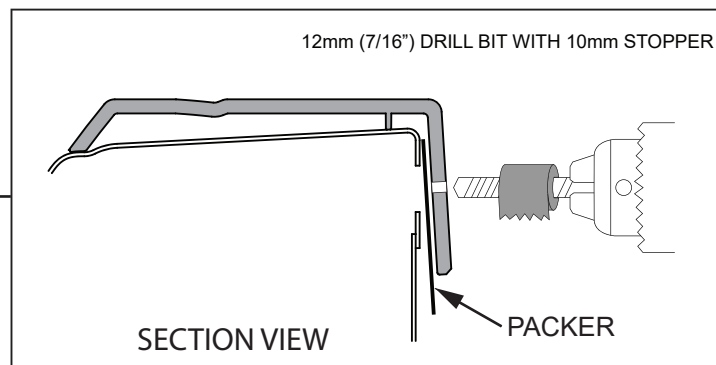
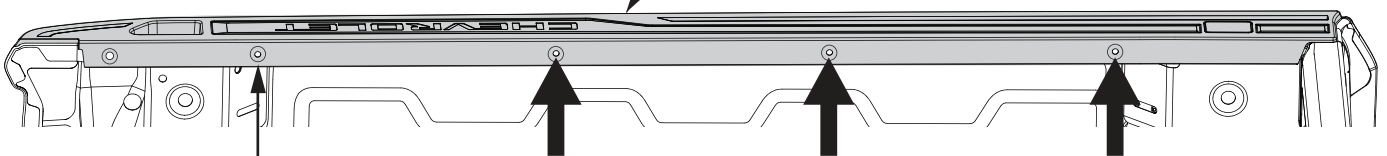

12mm (7/16") DRILL BIT WITH 10mm STOPPER

SECTION VIEW

PACKER

- 10** Using the pilot holes in bed cap (from step 9) as guides, enlarge the holes with a 12mm (7/16") drill bit. DO NOT touch the sheet metal while drilling (The use of a drill stop and/or a packer to protect the bed's sheet metal is recommended). Ensure the holes in plastic clear the holes in bed. Ensure step 6 to 10 is repeated for RHS.

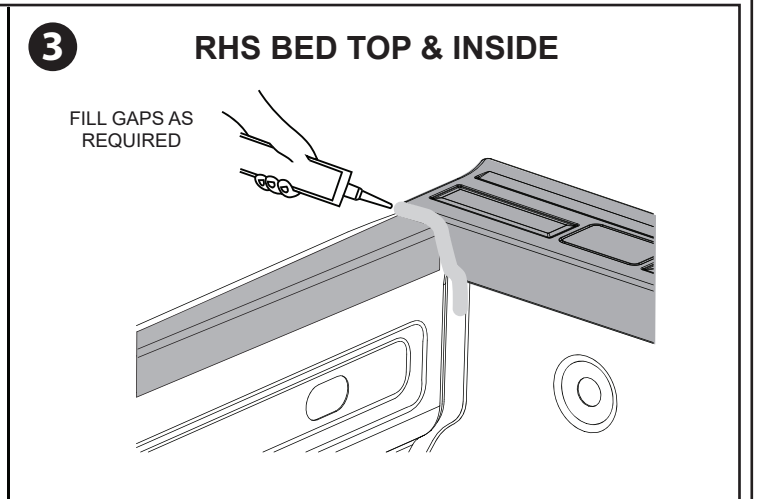
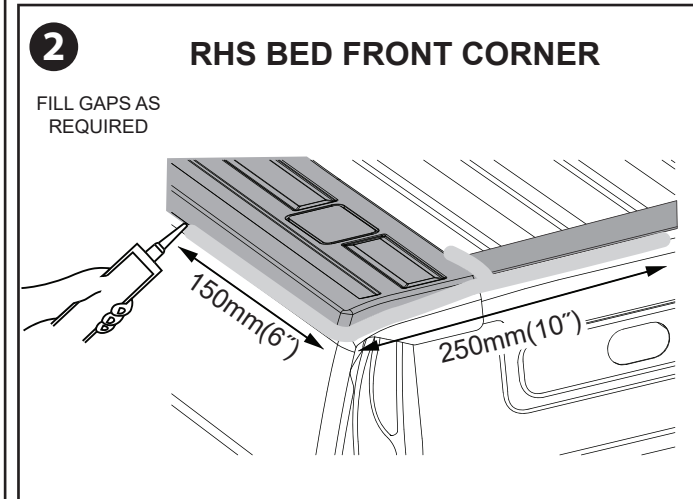
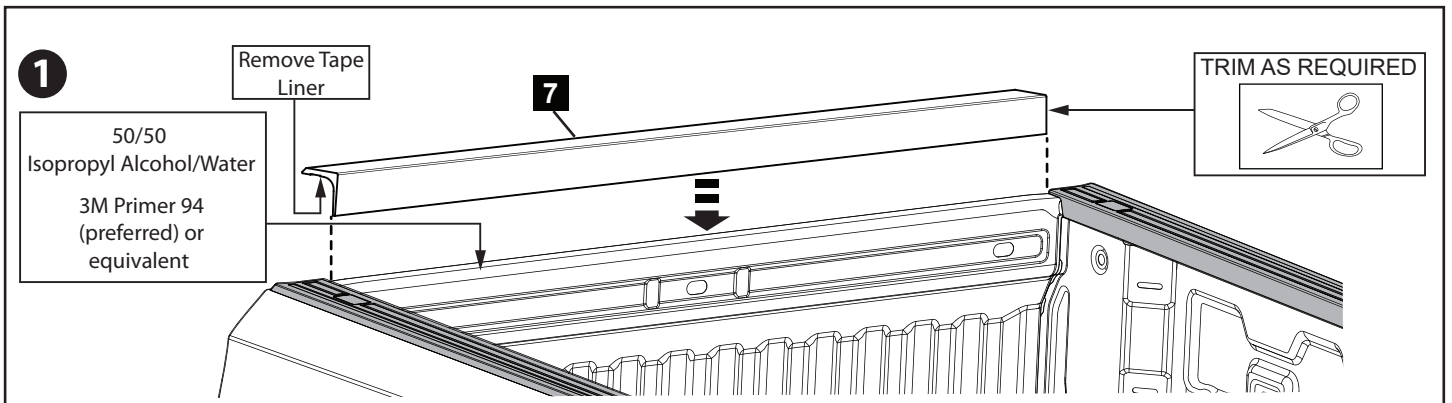

11 Clean the front top of the bed using Isopropyl Alcohol/Water mix and apply primer to the top area. Allow to dry. Place the extrusion (7) on front of the vehicle bed, check the length and trim to full width if required. Pre-peel 50mm (2") of the tape liner from one end of the Rubber Extrusion (7). Place the Rubber Extrusion on top of the bed as shown and centralise. Once in position, peel the liner and apply firm pressure from the top. Silicone the gap between the panels as shown on both sides. NOTE: Holes in the bed should be sealed with Silicone to prevent dust and water ingress as required.

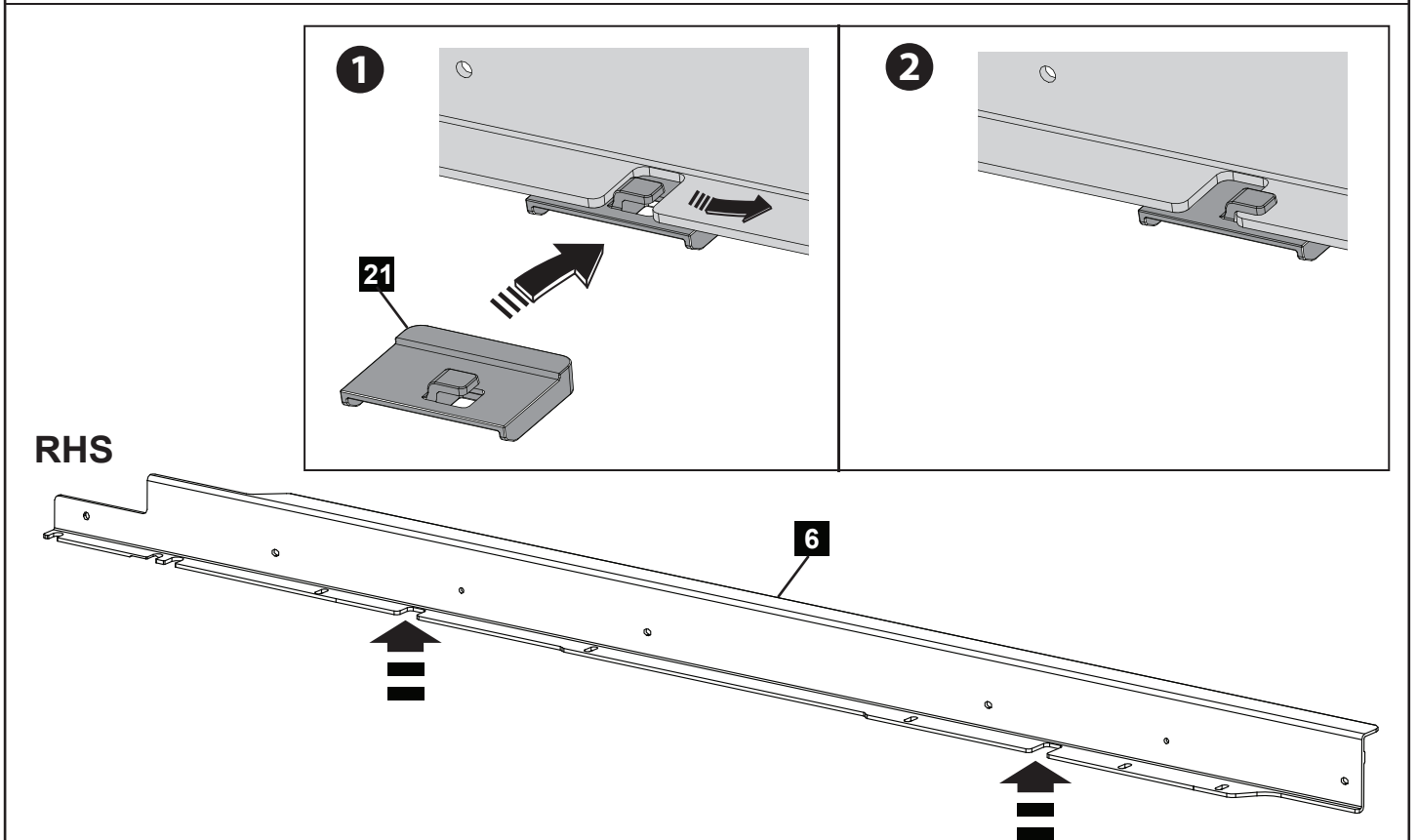

12 Fit two setup jigs (21) to the RHS mount extrusion (6) in locations shown. Jigs will be reused for the LHS.

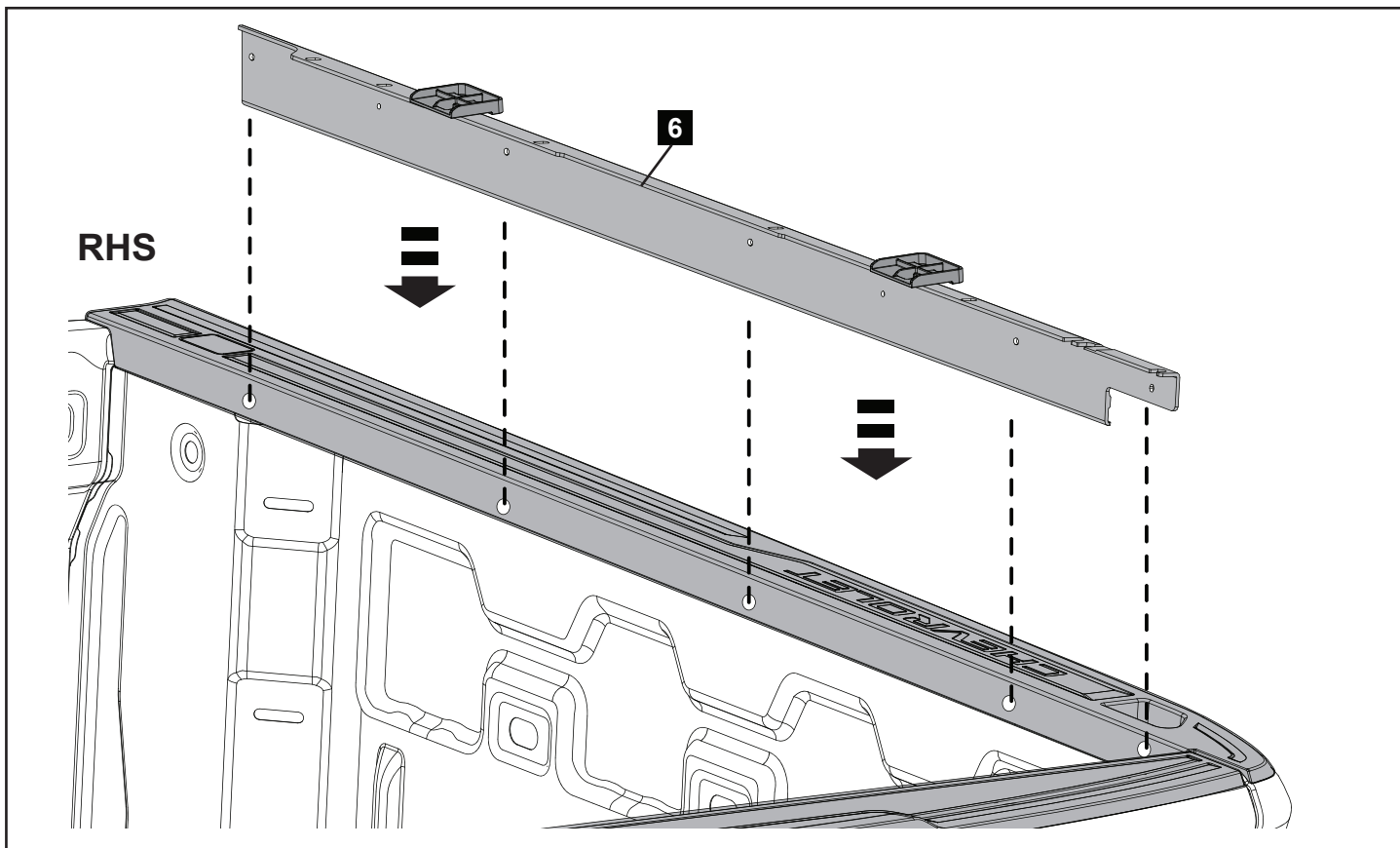

13 Place the mounting extrusion (6) on the inside of the bed until the setup jigs (21) rest on top of the bed cap. Align the 5 holes in the extrusion with the 5 holes in the bed side face (holes previously drilled in the plastic bed cap).

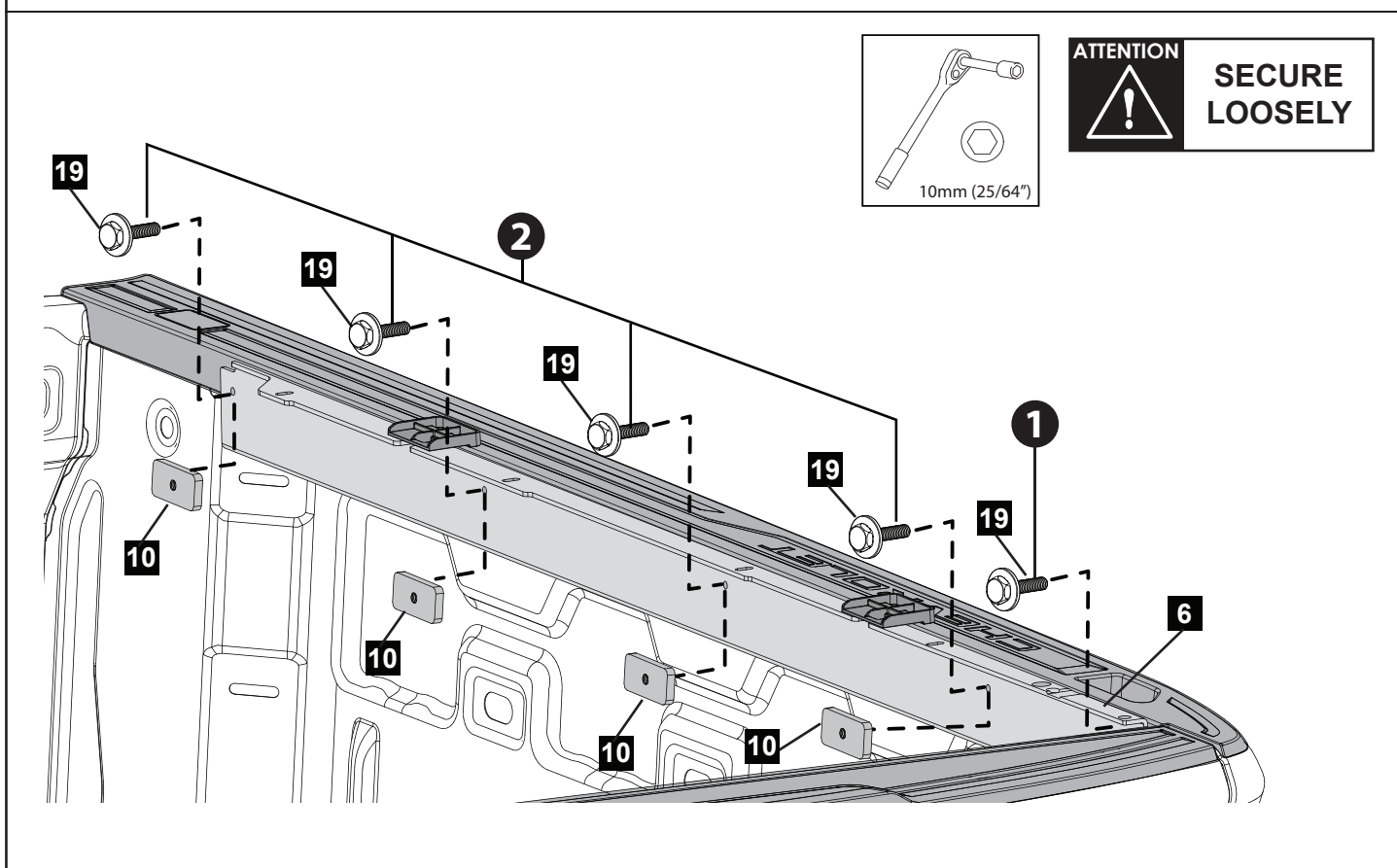

14 **1** Secure loosely the rear-most corner of the mounting extrusion (6) using 1 screw (19).
2 Then secure loosely the rest of the mounting extrusion (6) using 4 screws (19) and 4 tapped plates (10).
 NOTE: The last screw towards the rear of the bed will not require plate as it will screw into the previously fitted M6 clip.

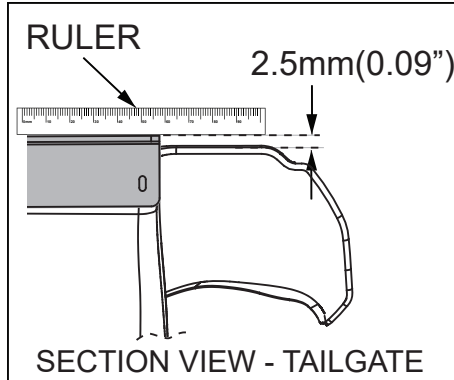
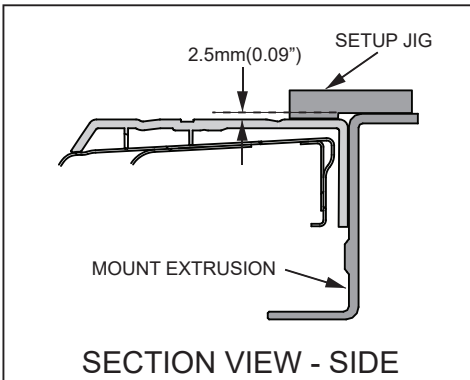
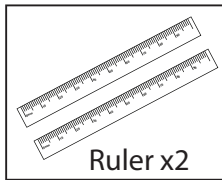
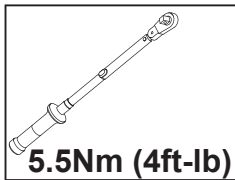
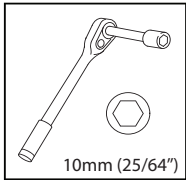

RHS

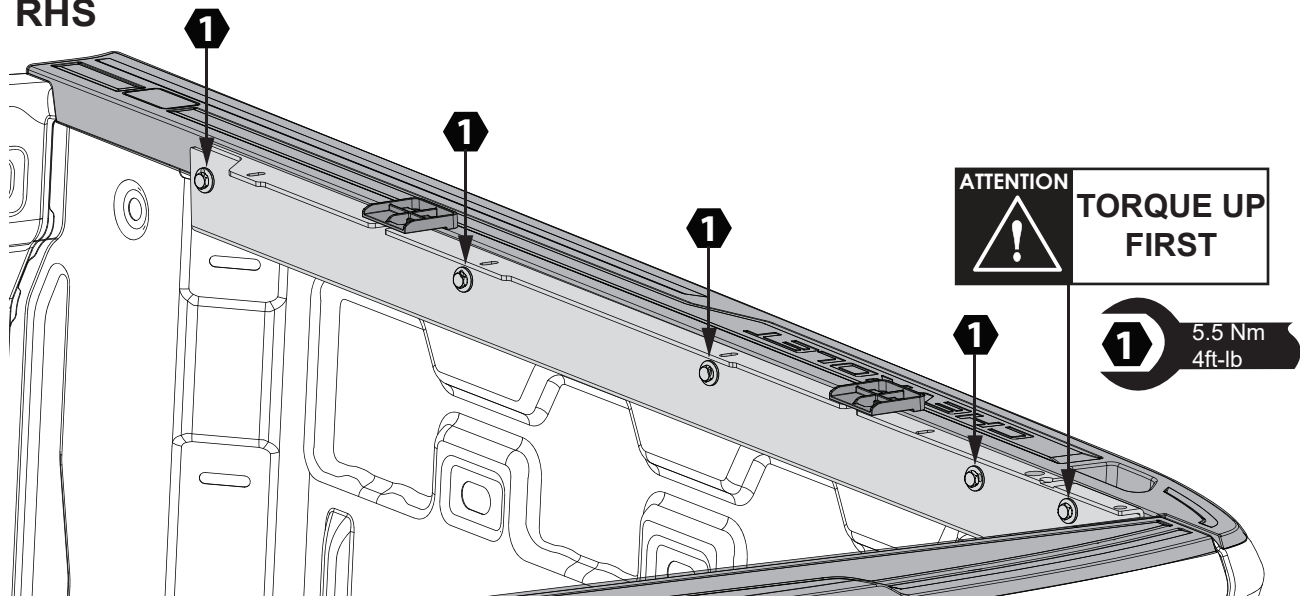

- 15** Set the vertical position of mounting extrusion by adjusting the extrusion relative to the bedcap (ensuring parts are held level). Use the setup jigs to achieve a 2.5mm(0.09") step between the front end of the extrusion Vs bed cap; and a 2.5mm(0.09") step between the rear end of extrusion Vs tailgate - as shown in detail views above. **IMPORTANT:** Torque-up the rear screw first. Torque all screws to 5.5Nm (4ft-lb). Verify the step is still 2.5mm(0.09"); if so, remove the setup jigs. Repeat steps 10-15 for the LHS.

THIS SECTION LEFT INTENTIONALLY BLANK

SECTION B

EGR RollTrac ASSEMBLY



DURING ASSEMBLY PROCEDURE SUPPORT AT CENTER OF CANISTER ONLY. PLACE ON TOP AND BASE CARTON (OR SIMILAR), COVER WITH FOAM BLANKET TO AVOID SCRATCHING POWDERCOATED SURFACES.

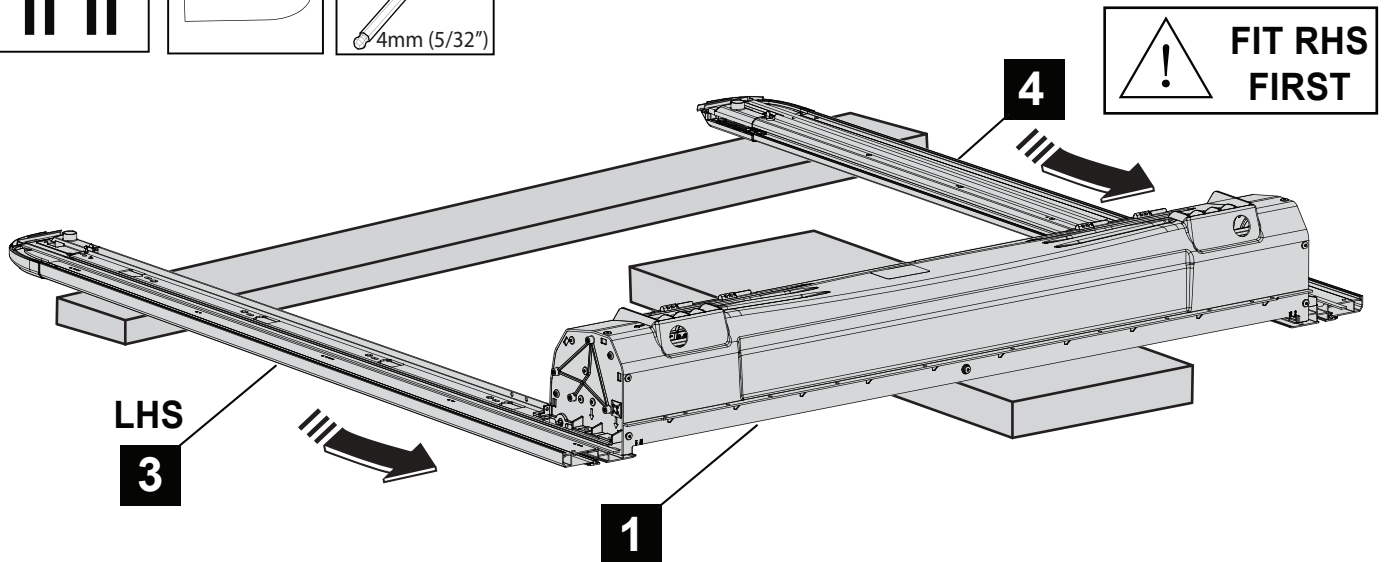
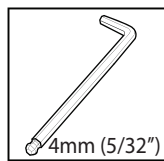
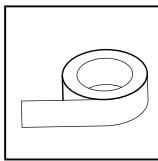

1 **ATTENTION: SEAL MUST FACE IN THE DIRECTION AS SHOWN. WARRANTY VOID IF ASSEMBLED INCORRECTLY.**

HOLD SEAL FLAT
USE CLOTH TAPE

RHS SHOWN

APPROX 300mm (12')

2 **ATTENTION: EXPOSE 3 SLATS PRIOR TO FITTING SIDE RAILS.**

ENSURE ENDS ARE ALIGNED

ATTENTION: WIPE THE SEAL AND SIDE RAIL WITH WAX & GREASE REMOVAL TO ENSURE THE CLOTH TAPE WILL ADHERE TO THE SIDE RAIL AND SEAL

1 Place the canister (1) on two protected boxes as shown, ensure hand rail and slat ends are aligned. Tape up the seal on the Side Rail (3&4) as shown.
IMPORTANT: Carefully align and slide the rail over the handrail endcap and canister endplate Details in following steps.



DURING ASSEMBLY PROCEDURE SUPPORT AT CENTER OF CANISTER ONLY, PLACE ON TOP AND BASE CARTON (OR SIMILAR), COVER WITH FOAM BLANKET TO AVOID SCRATCHING POWDERCOATED SURFACES.



1

RHS

2

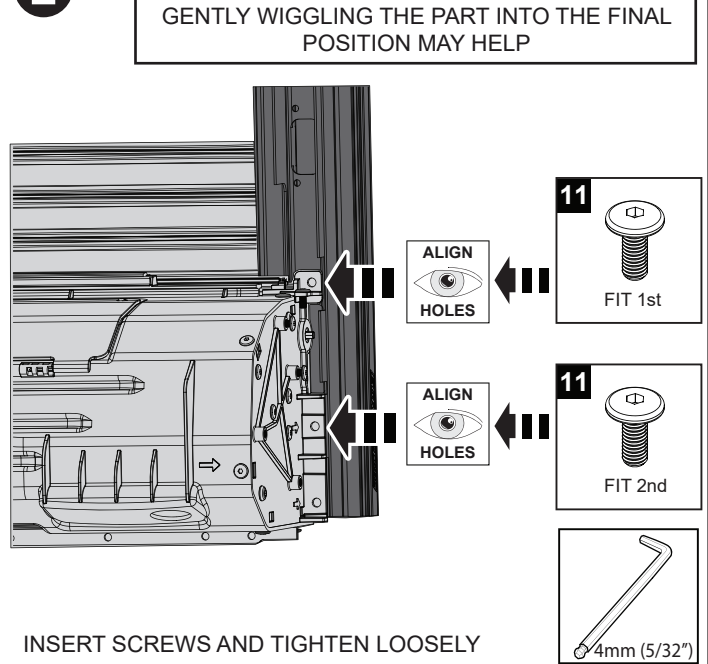
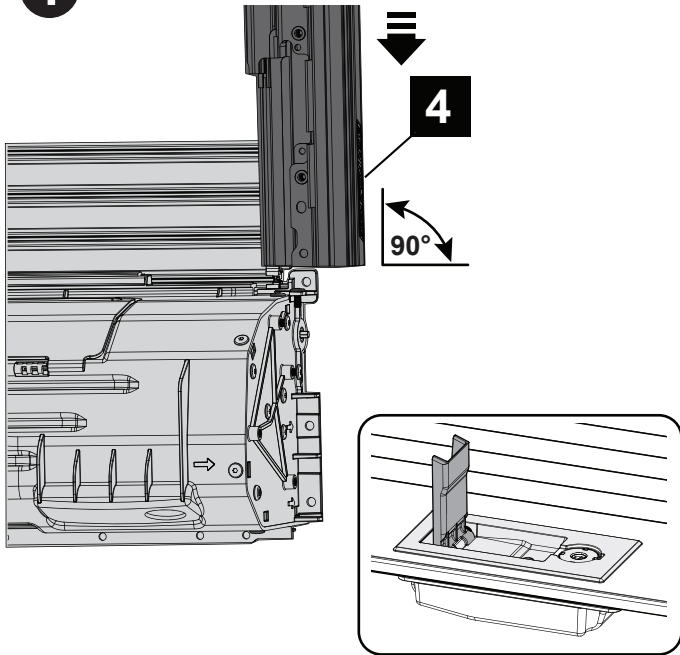

INSERT SCREWS AND TIGHTEN LOOSELY

2 Pull hand rail to expose 3 slats. Fully open handle to retract brake pads. Slide the rail over slat ends and onto endcap location pins. Align the holes and secure loosely with two screws (11). Do not tighten. Repeat for LHS Rail (3).

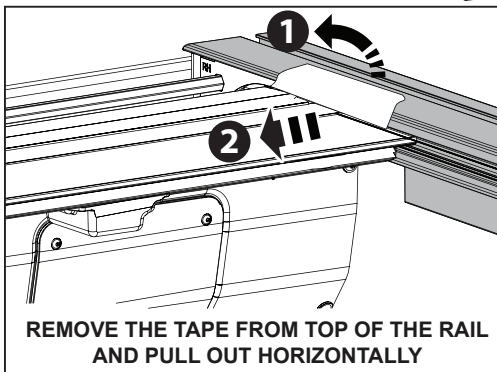
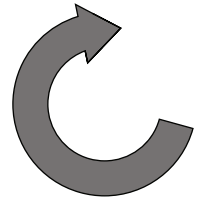
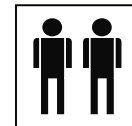
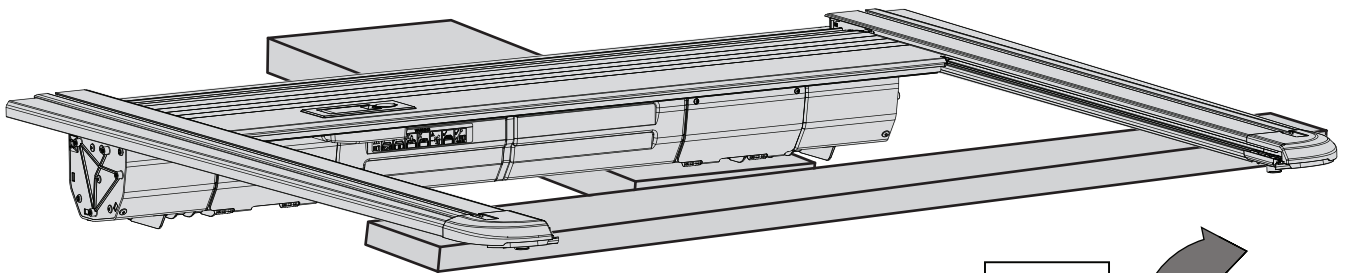

REMOVE THE TAPE FROM TOP OF THE RAIL AND PULL OUT HORIZONTALLY



ATTENTION: SEAL MUST FACE IN THE DIRECTION AS SHOWN. WARRANTY VOID IF ASSEMBLED INCORRECTLY.

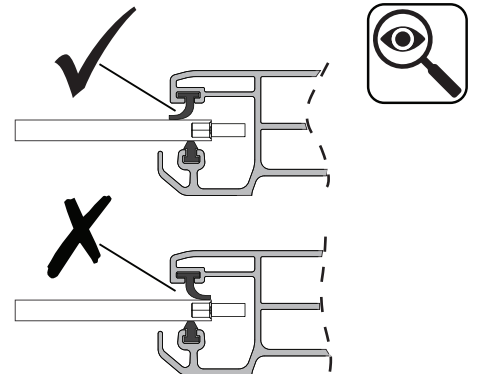
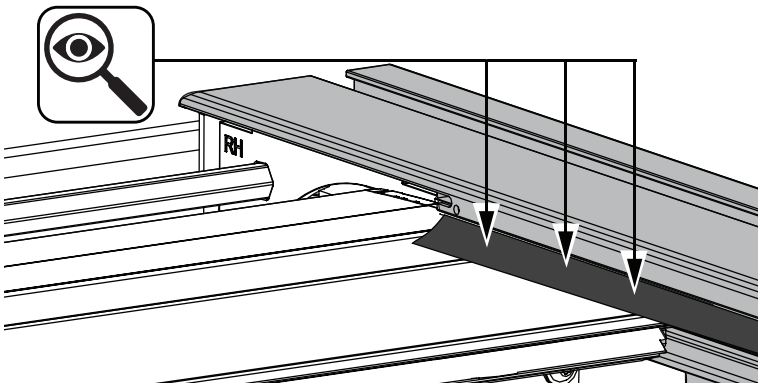

CHECK SEAL IS IN POSITION AND NOT DAMAGED

3 Carefully turn the assembly over and place onto a protected surface. Remove the tape holding the rubber seal and check the seal position as shown. Repeat for LHS Rail.

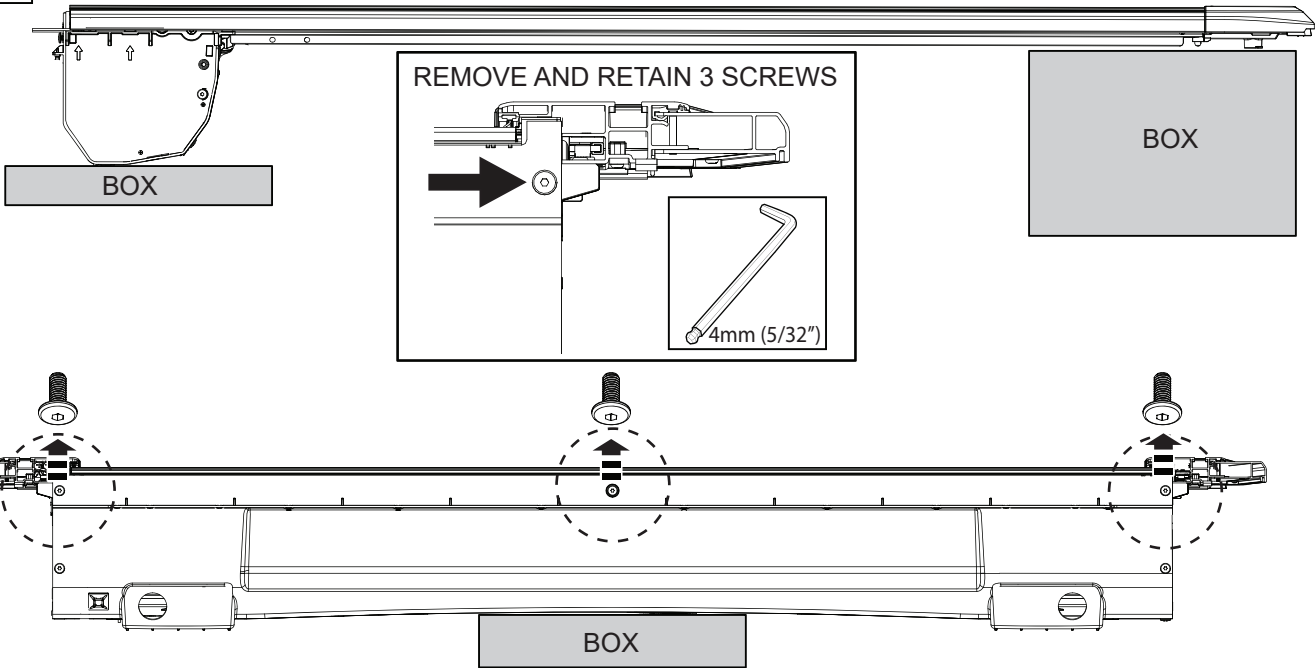

4 Remove the 3 pre-fitted screws from the rear of the cover which will be used to secure the Front Cover (2) to the assembly. NOTE: Ensure the product is not scratched or damaged when laying flat.

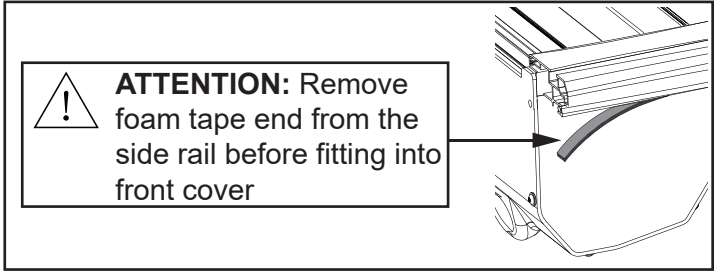
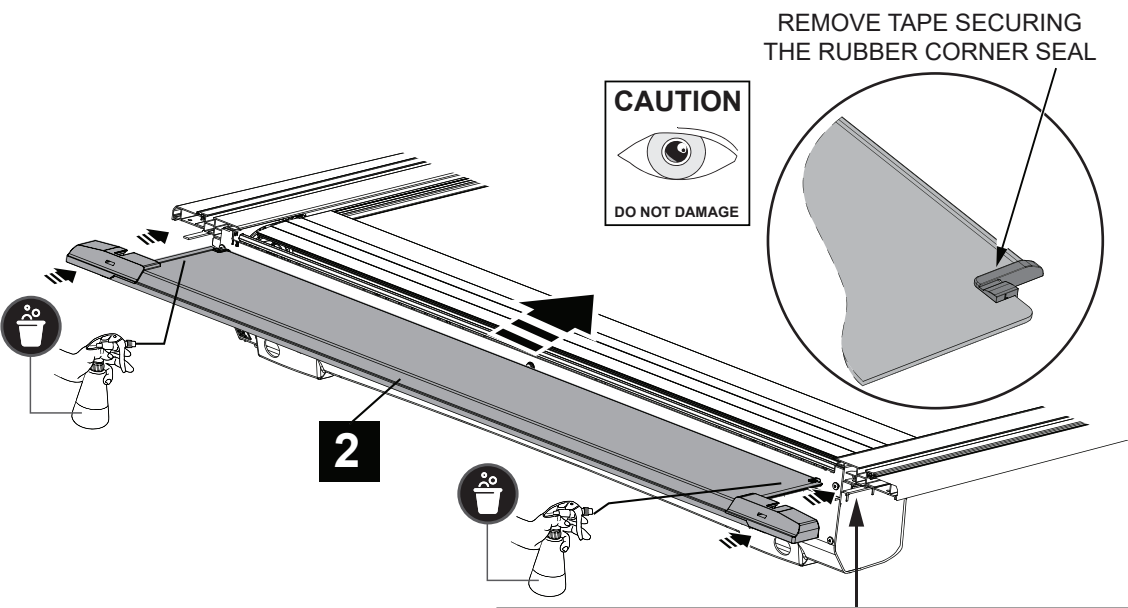
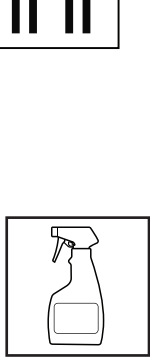

5 Slide the Front Cover (2) over the canister and into the side rail channels ensuring that the foam side rail tape is pulled out of side rail and the small rubber corner seal on the RHS and LHS of the front plate are not damaged. IMPORTANT: Spray the front cover edge with soapy water to allow it to slide easily into the sides, twisting side rails outwards will also help.

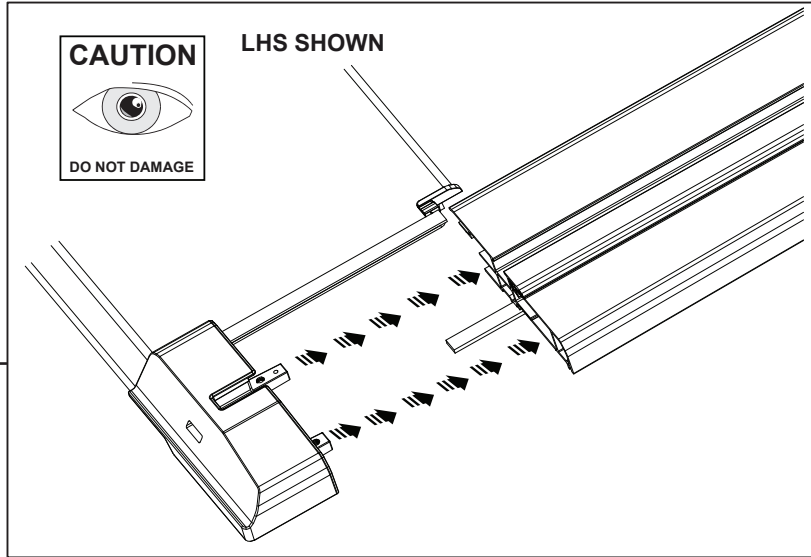
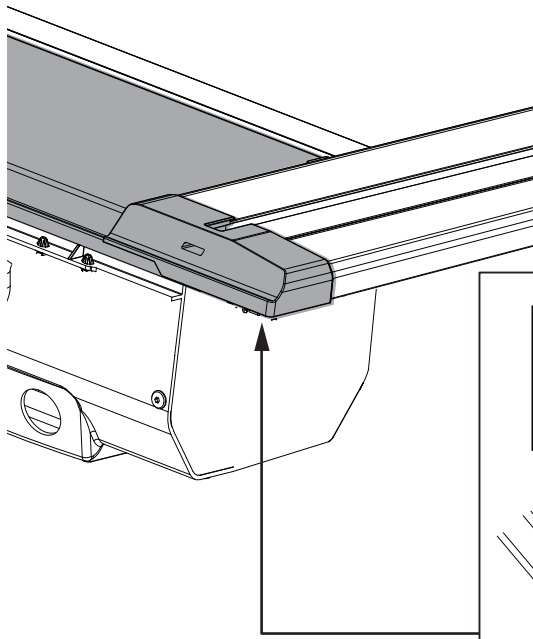

6 While sliding the front cover ensure the cast connectors are align.

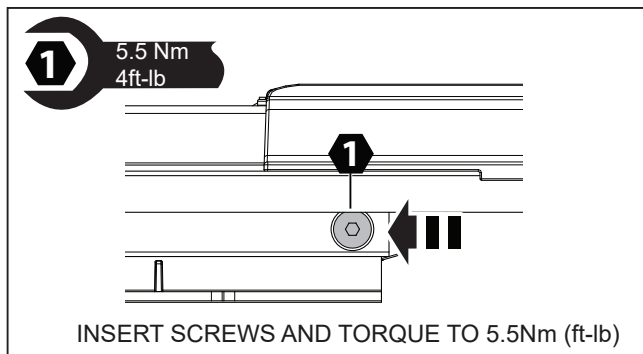
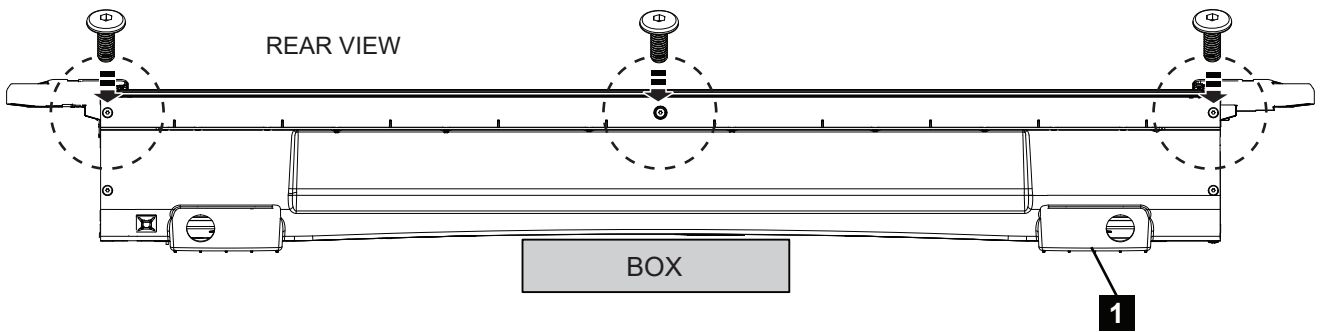
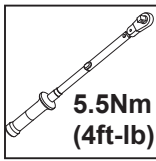
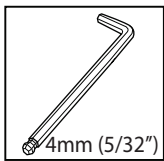

7 Using the 3 screws removed from Step 4, secure the Front Plate (2) to the Canister Assembly (1) and torque to 5.5Nm (4ft-lb).

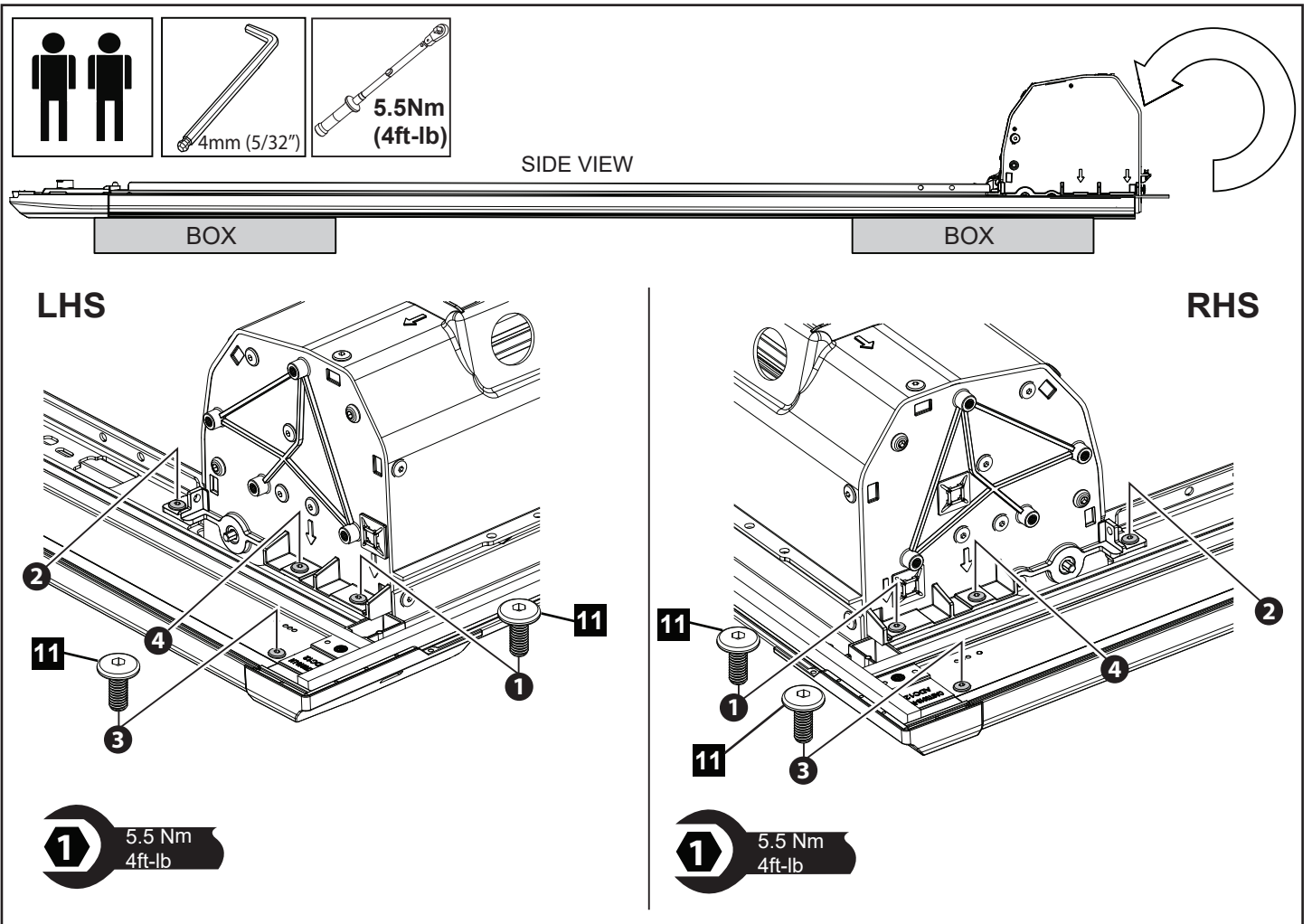

- 8** Carefully flip the assembly over onto a flat protected surface which will not damage the cover or scratch the paint work. Install the 2 screws (11) on each side through the canister and side rail into front cover. Torque all screws in order shown to 5.5Nm (4ft-lb).

LHS SHOWN - RHS IS A MIRROR IMAGE

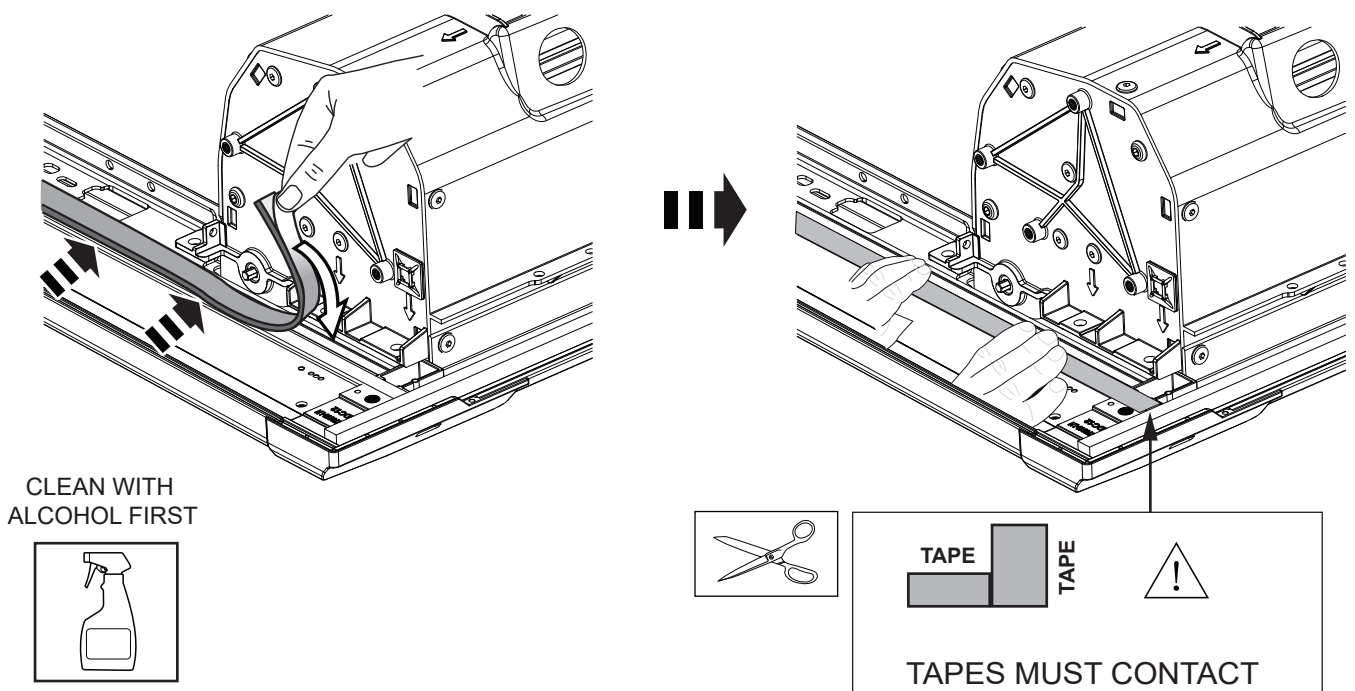

- 9** Clean powder coated surface first with alcohol spray. Trim foam tape length to ensure the end will butt against front cover seal - avoiding any gap. Peel the protective liner from the foam tape, adhere to the channel in the side rail, Press down firmly to secure. Repeat on RH side rail.

INSTALL RUBBER SEAL
IN SIDE RAILS

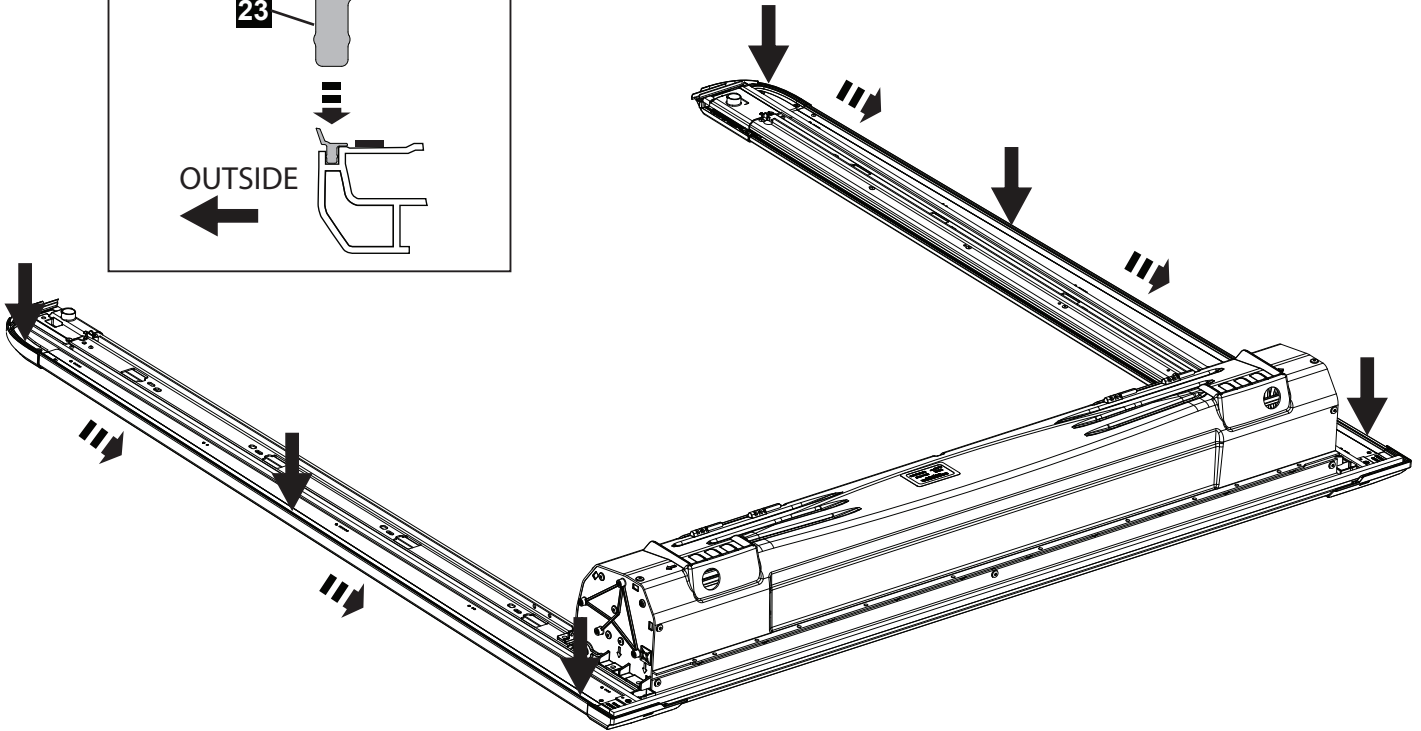
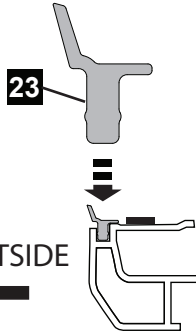

- 10** Install the Rubber Perimeter Seal (23) into each side rail and ensure seal is firmly seated (note the seal orientation).
Important: do not stretch the seal while fitting.

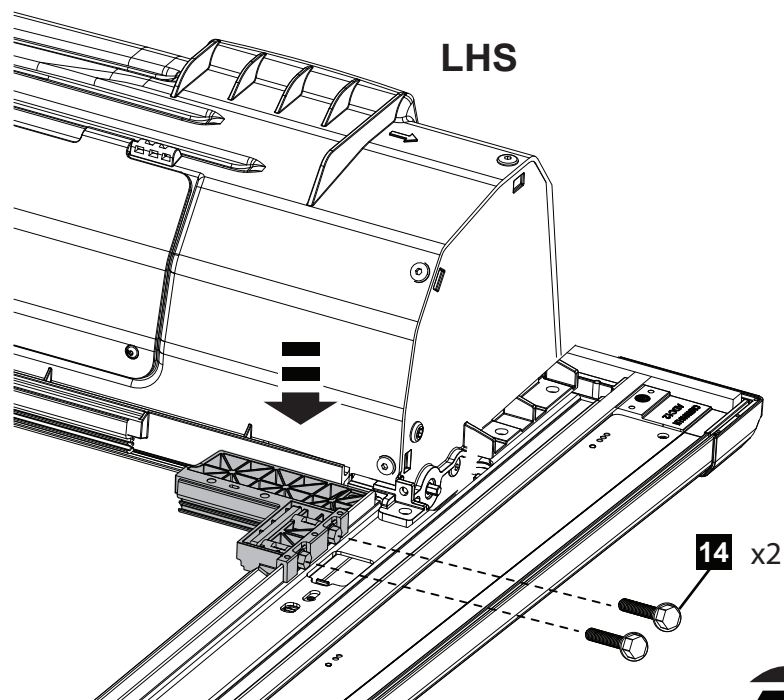
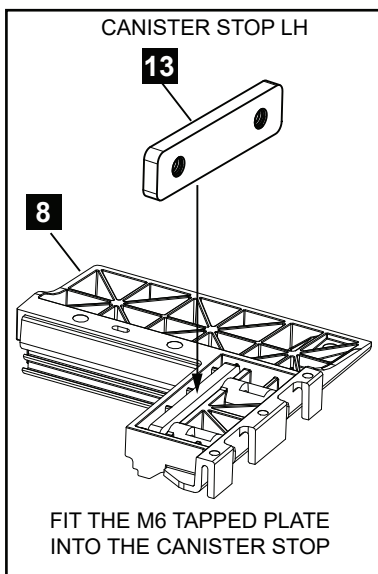
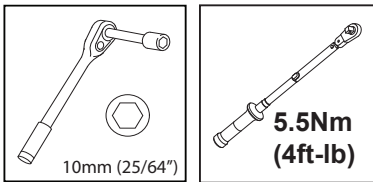

- 11** Fit the tapped plate (13) into the canister stop (8) as shown. Secure the LHS canister stop (8) with two M6 screws (14) and torque to 5.5Nm (4ft-lb). Repeat for the RHS.

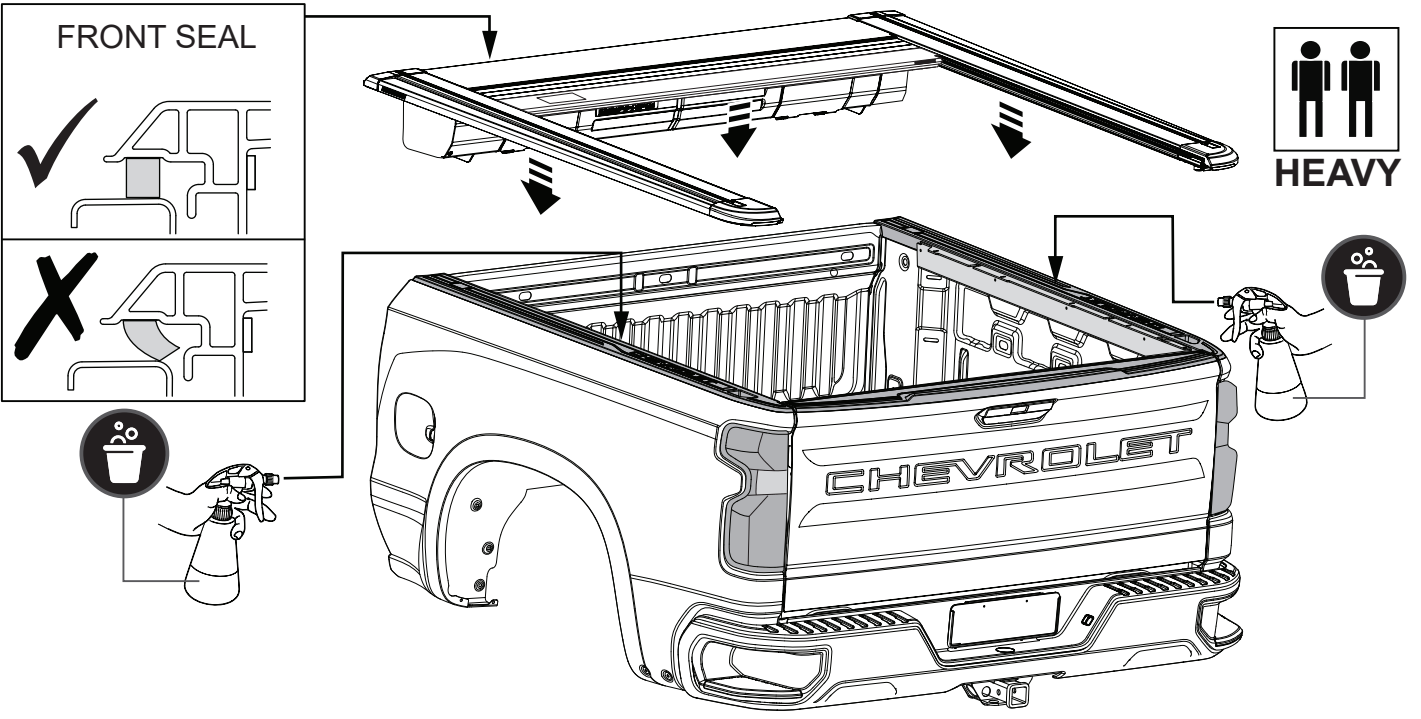

1 Spray the top surface of the bed liberally with a soapy water solution to enable the RollTrac to slide easily. Using two people to lift the cover from both sides and carefully lower it onto the bed. Ensure all seals are sitting vertically as illustrated.

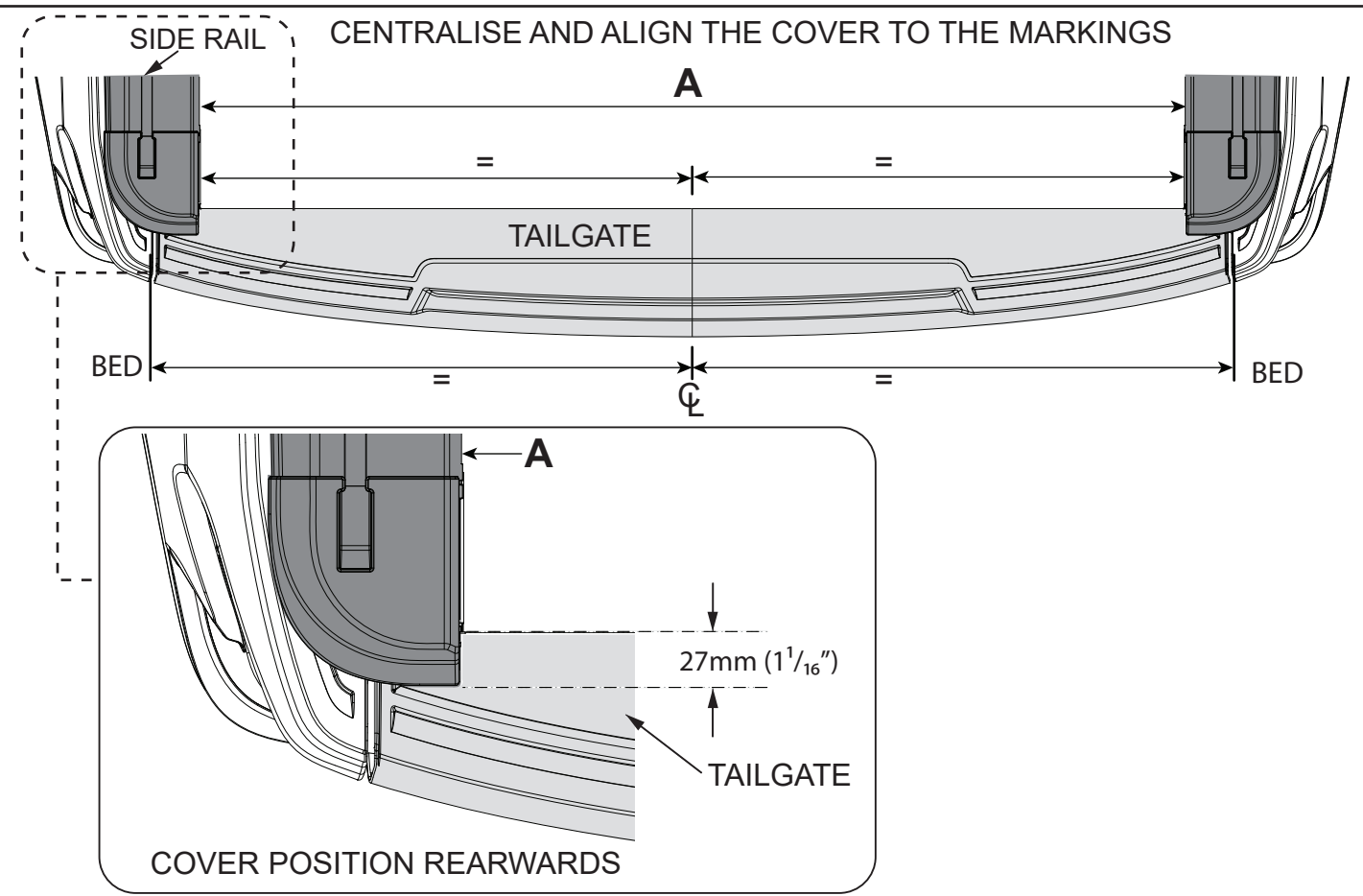

2 Apply masking tape at the center of the tailgate and each end to mark length. Measure the distance between the rear corners of the bed and draw a center line on the masking tape. Measure the distance from the marked center line to both rear corners of the RollTrac and ensure it is equally distanced. Adjust the cover so that it is aligned with the markings as shown. Ensure seals are not deformed by lifting cover and dropping vertically on bed.

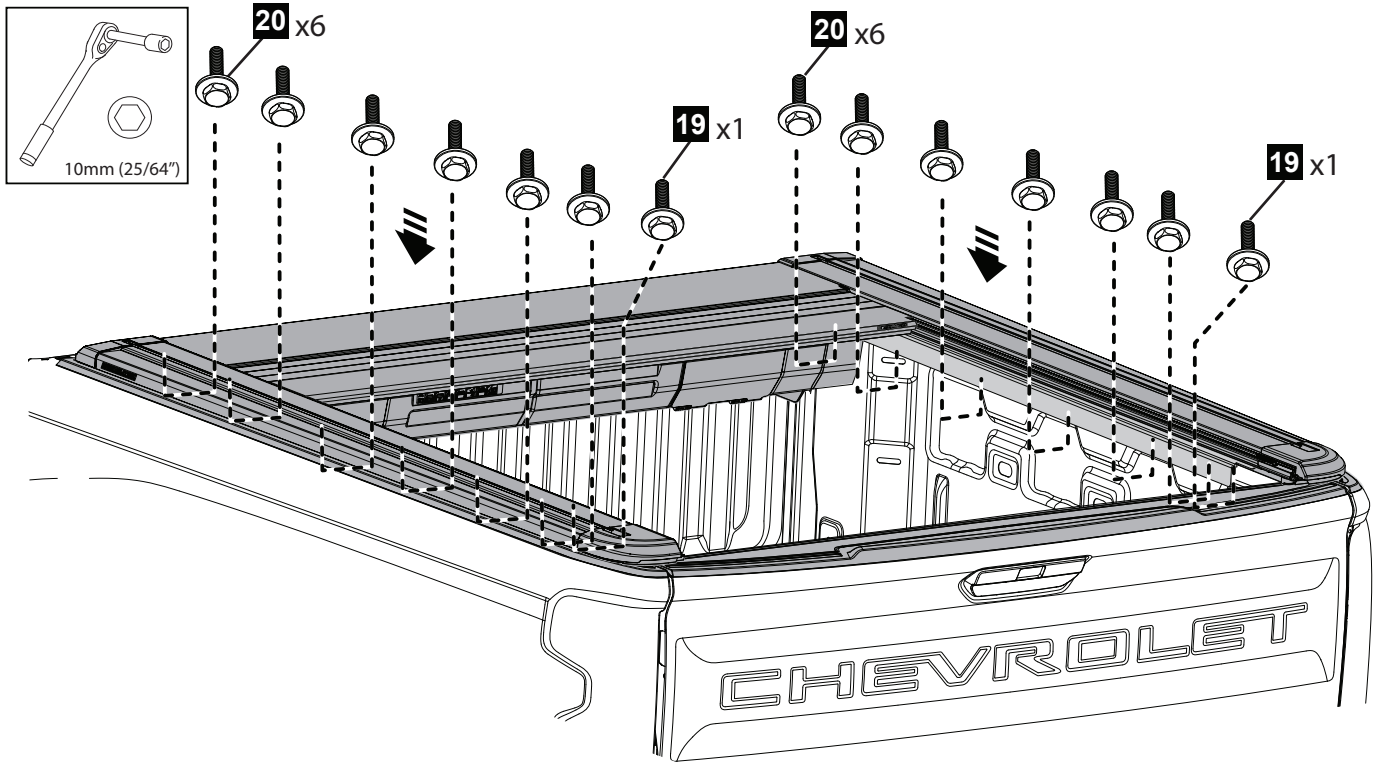

3 Assemble the Rolltrac side rail to the mount extrusion with screws on each side as shown, tighten loosely.

PERFORM FITMENT CHECK



A = A B = B

LIFT UP THE HANDLE AND
PUSH THE COVER MANUALLY

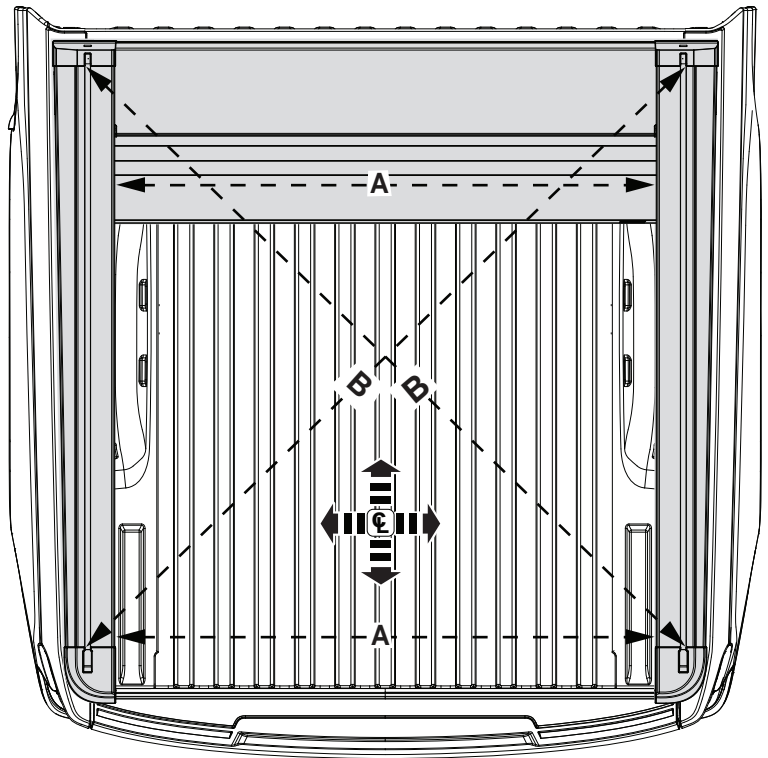
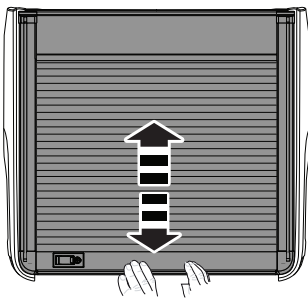
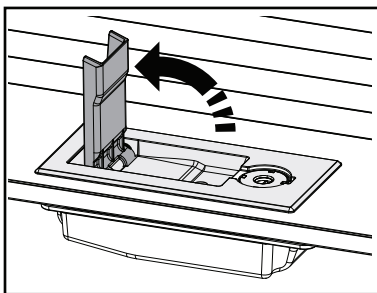

4 Perform width check (using canister end as reference) and diagonal fitment check (mounting bolts may need loosening for adjustment). Open and close the cover by hand, checking for smooth operation and consistent 1.5-2.0mm(0.06-0.08") side to side free-play of slat assembly within side rails. If there are any tight spots, then check side rail position and re-adjust side rail width as required.

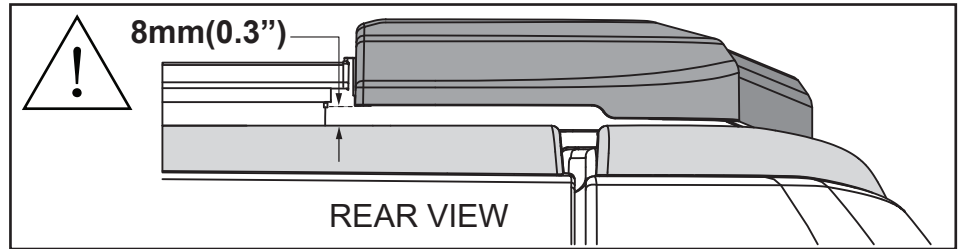
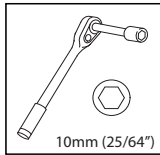
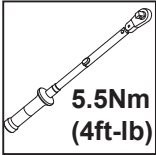

VIEW UNDER THE SIDE RAIL RHS (TUB NOT SHOWN FOR CLARITY)

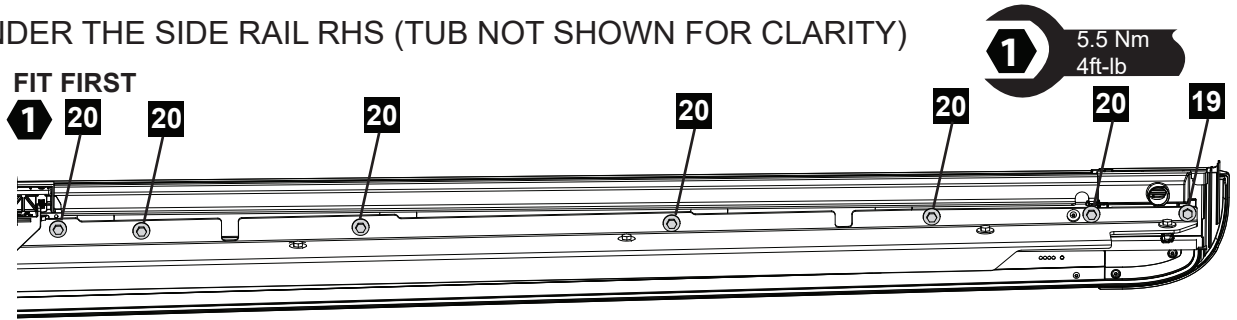

5 Working from RHS to LHS (to avoid one side lifting up) torque all screws (20)&(19) to 5.5Nm (4ft-lb). Perform final fitment check as per step 4 (section C). **IMPORTANT:** Check the clearance between rear corner casting and top of tailgate, target is 8mm(0.3"). Open and close the tailgate to check function of seal (makes contact with tailgate and does not over compress) if position requires adjustment refer to steps 12-15 (section A).

CONNECT FRONT DRAIN TUBES TO CANISTER

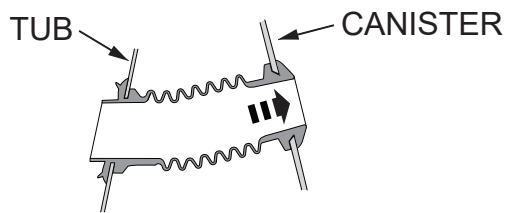

FIT REAR DRAIN TUBES TO SIDE RAILS

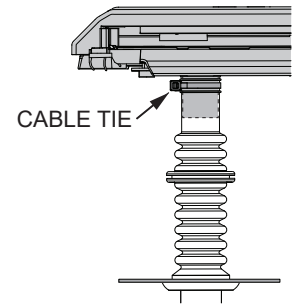

6 Connect the front drain tubes to the canister. Connect the rear drain tubes to side rails and secure with cable ties.

THIS SECTION LEFT INTENTIONALLY BLANK

SILICONE LUBRICATION TO THE SPIRALS (MODELS MAY VARY, IMAGES FOR REFERENCE ONLY)

- 1** Open tailgate and EGR RollTrac

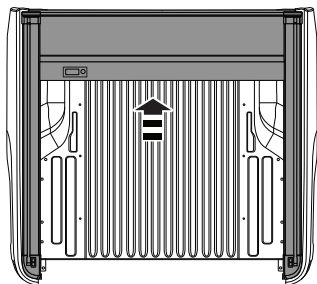
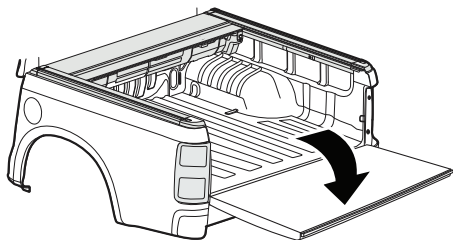

TOOLS REQUIRED:



Allen Key
2.5mm (3/32")



Silicone Spray

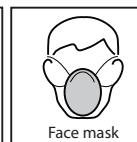

Face mask

- 2** Using a 2.5mm Allen Key remove the 4 screws and open the inspection covers.
WARNING: Keep clear of moving parts and avoid unnecessary operation of the EGR RollTrac while inspection covers are open.

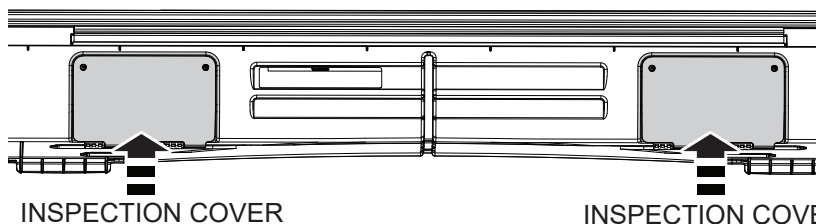

Allen Key
2.5mm (3/32")

- 3** Close the EGR RollTrac to access canister internals

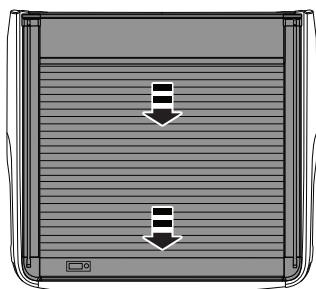

- 4** To avoid water leaks, look into the inspection points and check that the flanges of both front drain tubes are correctly engaged to the canister cover (without any kinking etc.), readjust if required.

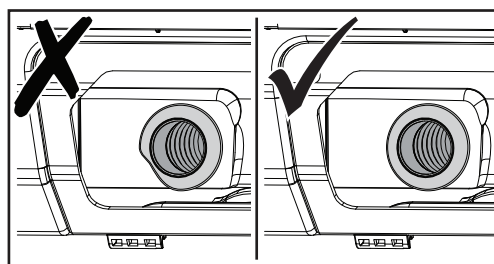

- 5** Using plastic compatible 100% Silicone Spray (ONLY) spray onto the spirals on both ends of the canister through the inspection points.

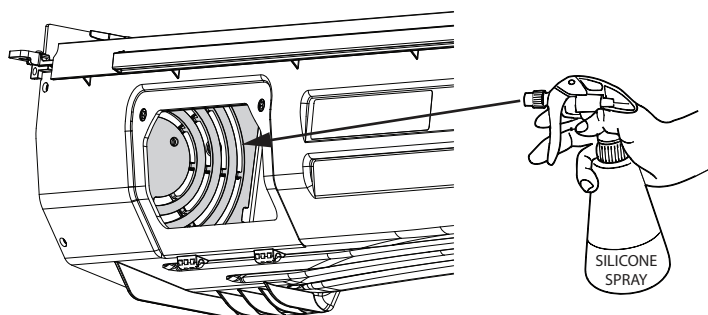

- 6** Open the EGR RollTrac

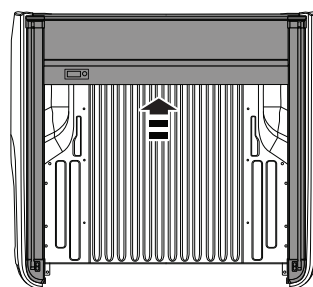

- 7** Close the inspection covers and secure with retained screws. Open and close the EGR RollTrac to distribute lubricant and check operation.

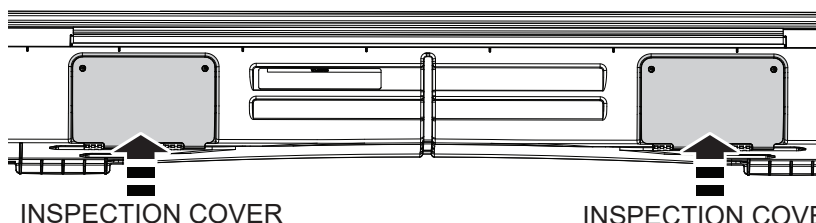

Allen Key
2.5mm (3/32")

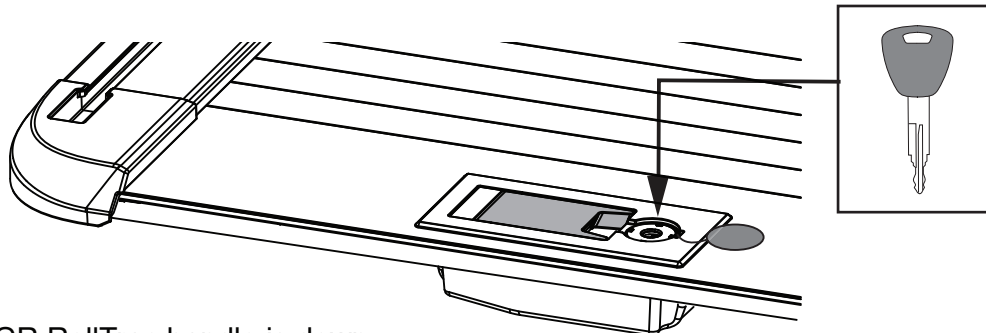
Locking / unlocking using key:

1. Ensure the EGR RollTrac handle is down.
2. Open the rubber cap covering the lock and using the provided key turn LEFT (CCW) to lock and RIGHT (CW) to unlock the hand rail.
3. Ensure the lock cap is pushed down to seal the lock.
Note: handle must be folded down prior to locking / unlocking with key. Ensure the lock cap is pushed down to seal the lock after every use.

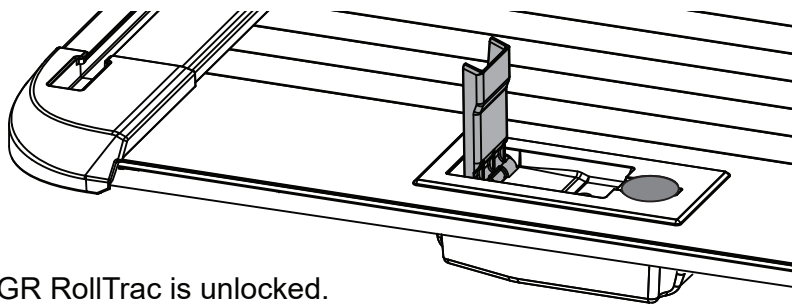
Opening & Closing Procedure:

1. Ensure the EGR RollTrac is unlocked.
2. Lift the handle 90 degree up, in order to release the latches from the tailgate rail and open the vehicle tailgate. Lifting the handle to 90 degrees will provide a hand hold so that the user can pull the cover into the next index position.
3. To ensure the EGR RollTrac is properly engaged in the desired position, gently push the handrail at both ends, if excessive movement is observed reposition the hand rail as required.

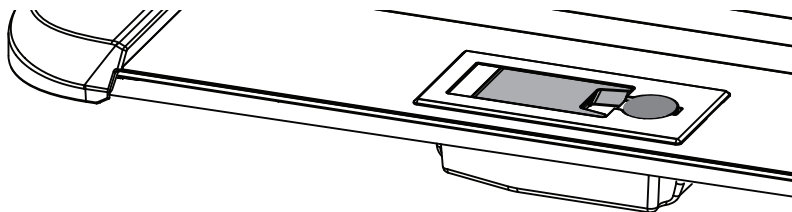

4. Set the hand rail to desired position and fold the handle down.
NOTE: Cover should open and close smoothly. If cover does not lock or open correctly, please refer to the trouble shooting section in the Owners Manual.

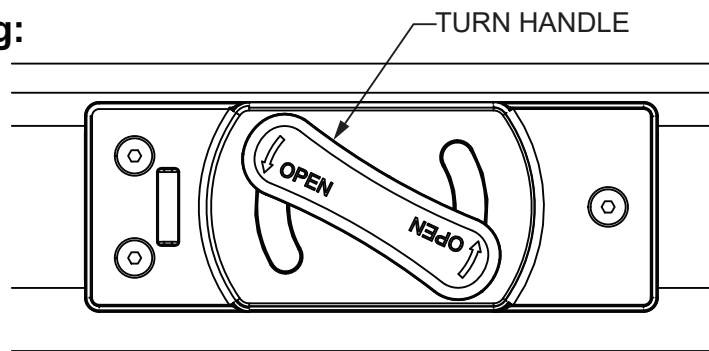
Emergency Opening:

Turn the emergency release handle located on the centre of the hand rail assembly and retract the EGR RollTrac.

RIVETING SIDE BRACKETS

ROLLTRAC NOT SHOWN FOR CLARITY (RHS)

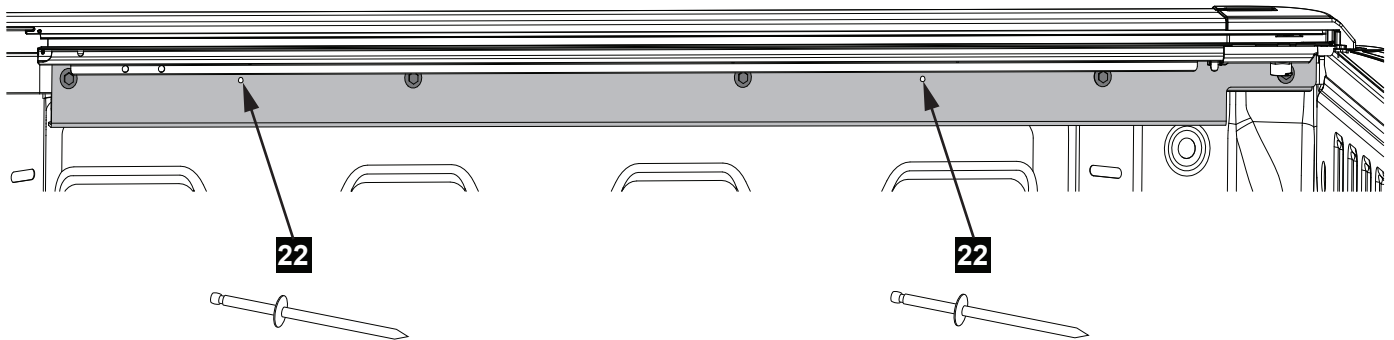

- 1 After running all fitment checks, confirming all functions and running calibration, drill the 2 hole locations using 5mm (3/16") drill bit. Secure the brackets with rivets (22) as shown. Repeat for LHS.
NOTE: Apply rust inhibitor to drilled holes.

FINAL NOTES

Dispose of all packaging and waste according to local regulations.
Retain your Owners Manual, Fitting Instructions and fitting jigs for future reference.
Refer to Owners Manual for operation, warranty, service and product care guidelines.
Complete the installation check list in Owners Manual and store keys safely.
Clean the EGR RollTrac using multi purpose cleaner to remove any residue from packaging and installation.