



RHINO-RACK

RVP51/RCH Supplement - Mazda CX-9 2016

Important: Please read these instructions carefully prior to installation.
 Please refer to your fitting instruction to ensure that the Roof Rack System is installed in the correct location.
 Check the contents of kit before commencing fitment and report any discrepancies.
 Place these instructions in the vehicle's glove box after installation is complete.

Maximum load carrying capacity: 75kg / 165lbs.

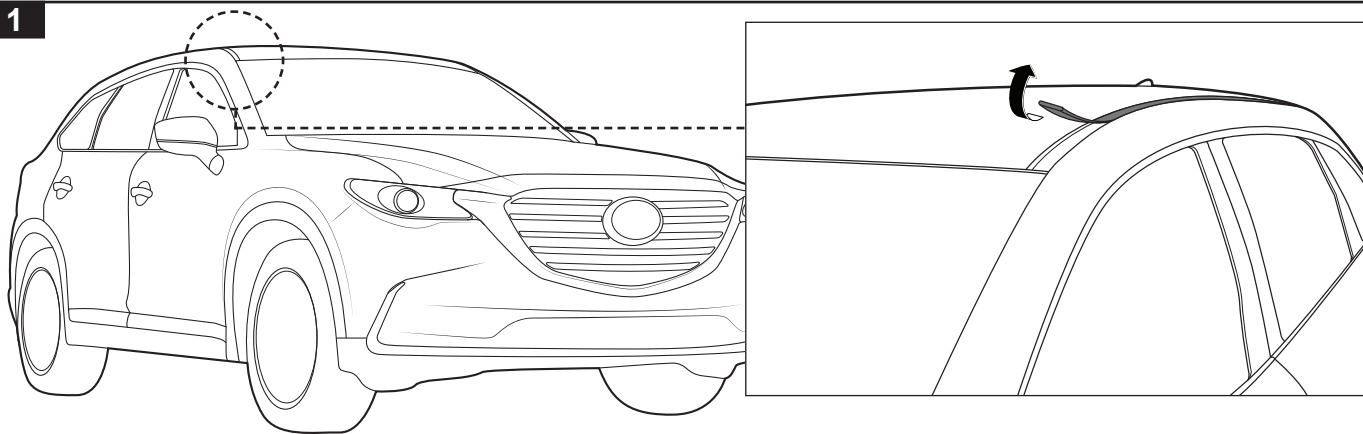

2 Locate the mount point brackets in the roof ditch. Screw in fixed mount studs as shown. Note: For a 2 bar system, use front and middle mounts only.

Screw a stud into the front mount point of the front and rear bracket.

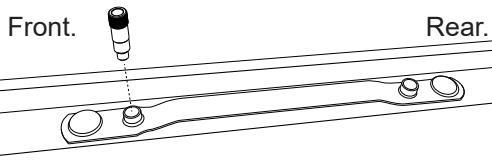

Screw a stud into the rear mount point of the centre bracket.

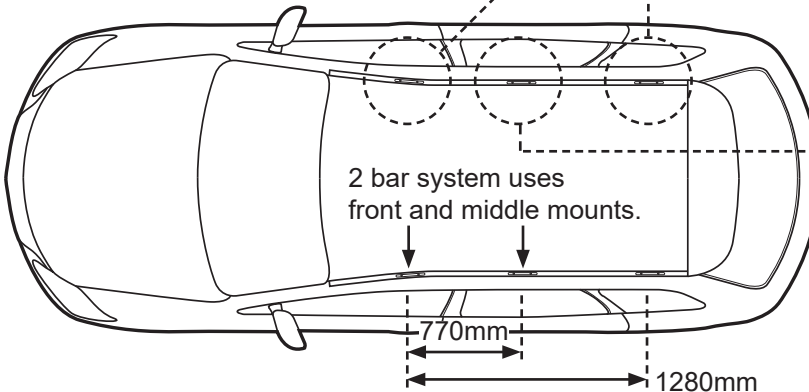
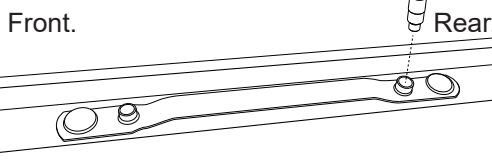

3 Place the ditch mould next to the installed studs. Mark the point where the mould would sit over the thread on the bracket. Use the measurements in the bottom left as a guide. Always physically check against vehicle.

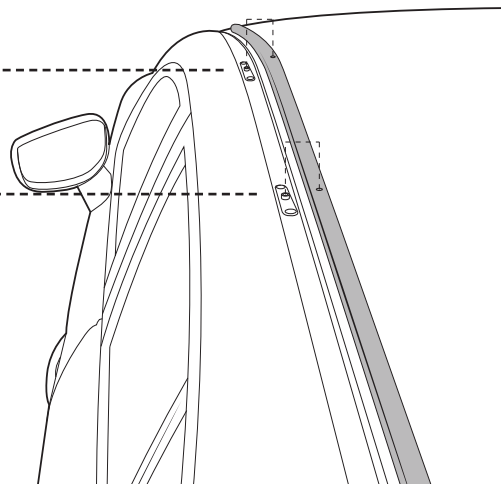
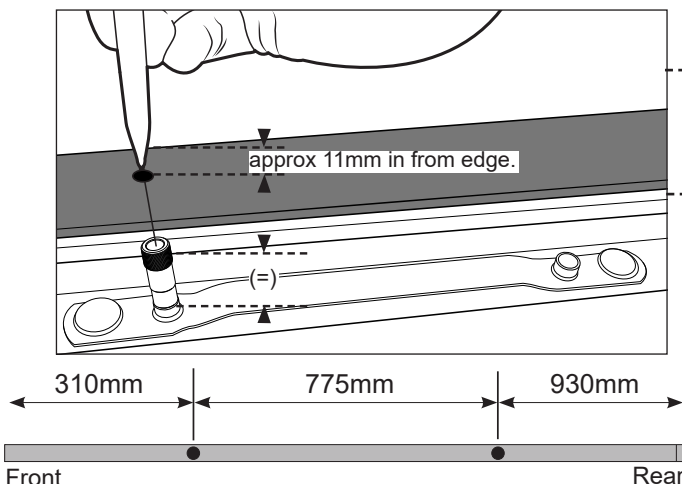



RVP51 Supplement - Mazda CX-9 2016

4

Use a 3mm bit and drill a pilot hole through the references made previous. Now use an 11mm drill bit and open up both holes on the ditch mould.

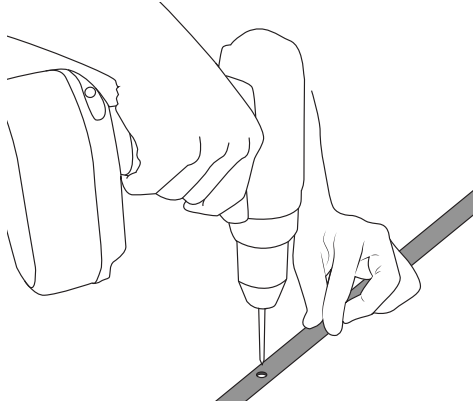

Use a dremel and a fine sand head, clean up the holes made in previous step. A de-burring tool can be helpful.

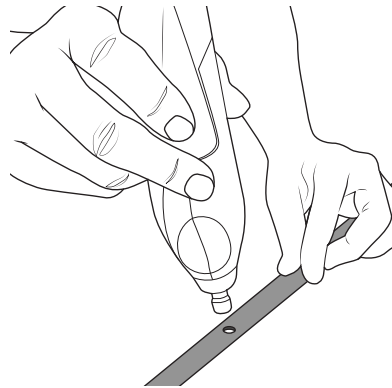

Replace the ditch mould. The studs will poke through the holes drilled in the mould.

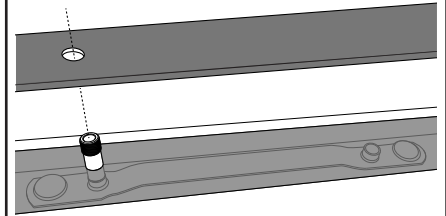

Leg kit: RVH2 RVL2
Front bar: 1050mm
Middle: 1005mm
Rear bar: 996mm (opt)
Base kit: RCP46-BK

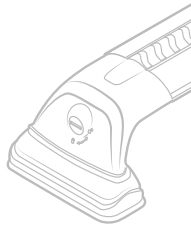

Leg kit: RCH2
VA Bar: VA126S/B
Base kit: RCP46-BK

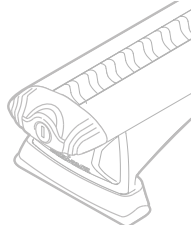

Leg kit: RCH4 (optional 3rd bar)
HD Bar: RB1250S/B
Spacers: QMHD05
Base kit: RCP46-BK

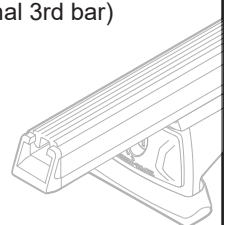

Note: A level, 3 crossbar system, can be achieved using the following:

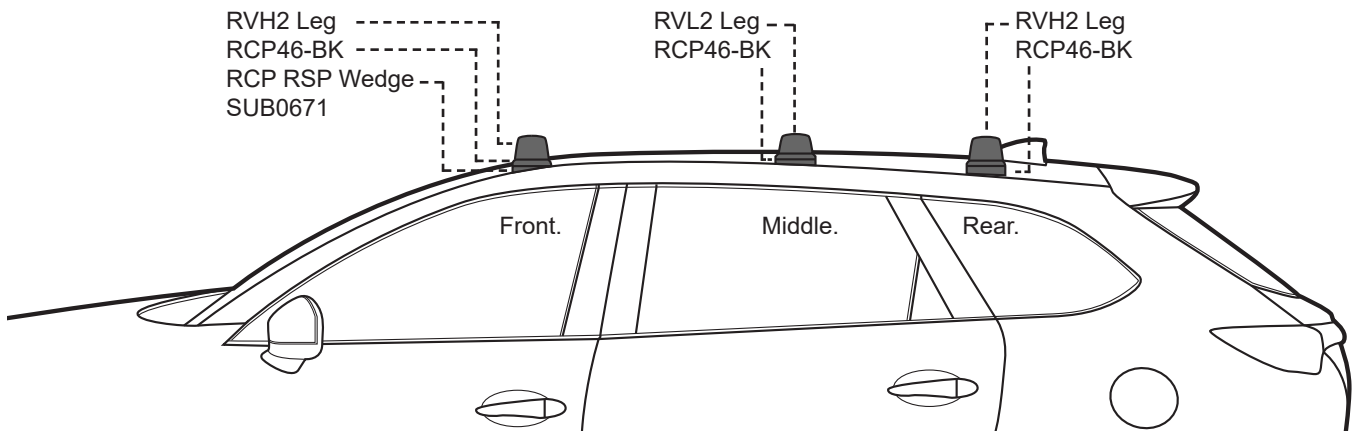

Note Vortex crossbars can be cut to length to fit this vehicle. Measure the desired length out **from the centre of the Vortex Bar** and create a reference with a marker. Carefully cut the bar at these markings using a Saw with an Alloy Cutting Blade.

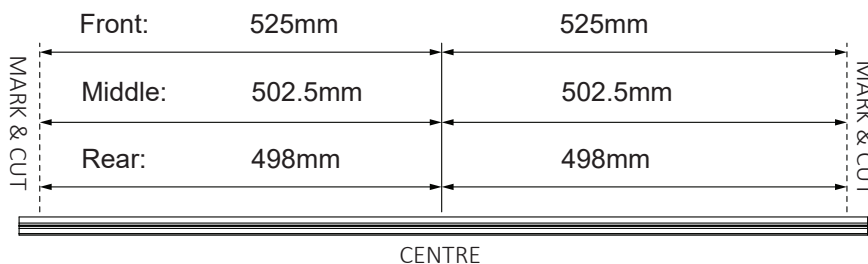

Cut the Bar at the required length.

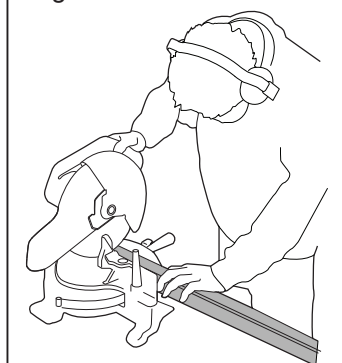

Note for dealers when altering a RSP kits:
Add 38mm to sports bar measurement for RVL.
Add 40mm to sports bar measurement for RVH.