



GATORBACK MUDFLAPS

GCR42F 2017 F150 Raptor Front Gatorback CR Mudflap Kit Installation Instructions

IMPORTANT

The manufacturer is not responsible for negligent use of vehicle with mudflaps installed, including over-tightening of screws and bolts causing damage to vehicle or mudflaps.

TOOLS REQUIRED:

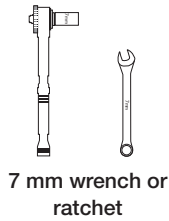

7 mm wrench or ratchet

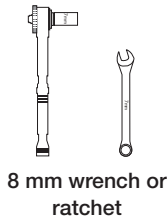

8 mm wrench or ratchet

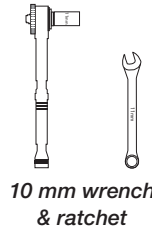

10 mm wrench & ratchet

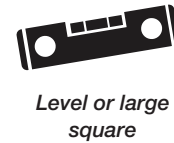

Level or large square

PARTS:

1. (2) Gatorback CR Mud Flap (DS & PS)

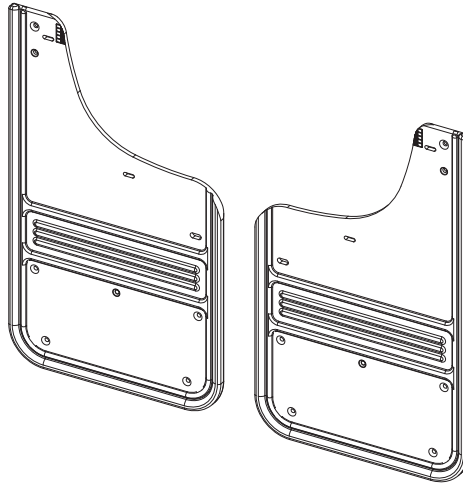

2. (2) Washer Plate (DS & PS)

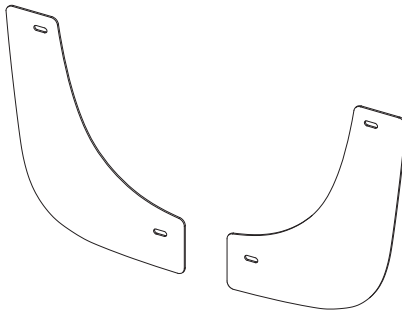

3. (2) Brace (DS & PS)

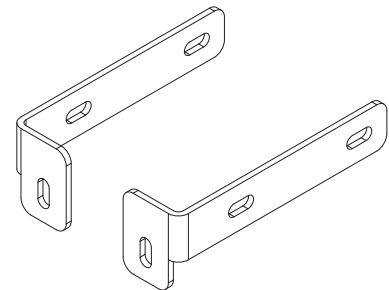

FASTENERS:

4. (4) Flanged Hex Head Screw
M4.2-1.41 x 28mm



5. (4) Black Nylon Washer
0.2" ID 0.45" OD



6. (2) Hex Head Cap Screw
M6 x 25mm



7. (2) Oversize Washer
0.281" ID 1.0" OD

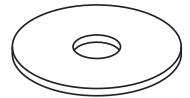

8. (2) Aluminum Washer
0.265" ID 0.688" OD

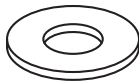

9. (2) Lock Washer
M6



10. (2) Hex Nut
M6

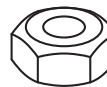

11. (4) Serrated Flange Nut
M6



INSTALLATION:  Installation video available on our YouTube channel: youtube.com/c/TruckHardwareLtd

Note: Please refer to diagram during installation. Power tools not recommended.

1. START ON DRIVER SIDE (DS) FRONT

2. INSTALL GATORBACK CR MUD FLAP (DS) AND WASHER PLATE

- a. Remove 2x factory fender flare screws on inner fender.
- b. Loosely install driver side Mud Flap (#1) and Washer Plate (#2) using 2x #8 Flanged Hex Head Screws (#4), and 2x Nylon Washers (#5).

3. INSTALL BRACE (DS)

- a. Locate two existing M6 factory bolts directly behind mudflap, on the underside of the body.
- b. Loosely install Brace onto M6 factory bolts using 2x M6 Serrated Flange Nuts (#11).
(Note: threads may need to be cleaned of any paint overspray)
- c. Loosely attach Brace (#3) to Mudflap (#1) using 1x M6 Head Cap Screw (#6) and 1x Oversize Washer (#7), secured with 1x Aluminum Washer (#8), 1x Lock Washer (#9), and 1x Hex Nut (#10).

4. ADJUST MUD FLAP POSITION AND ALIGNMENT

- a. Adjust horizontal position of mudflap.
- b. With a level (bubble/digital) on the bottom edge of the mudflap, adjust until level.
- c. Carefully tighten all screws and double check that mudflap is still level.
- d. Adjust forward-back position of Brace so that mudflap is approximately parallel to tire tread.

5. TIGHTEN ALL FASTENERS

6. REPEAT PROCEDURE ON PASSENGER SIDE (PS)

DIAGRAM (DRIVER SIDE)

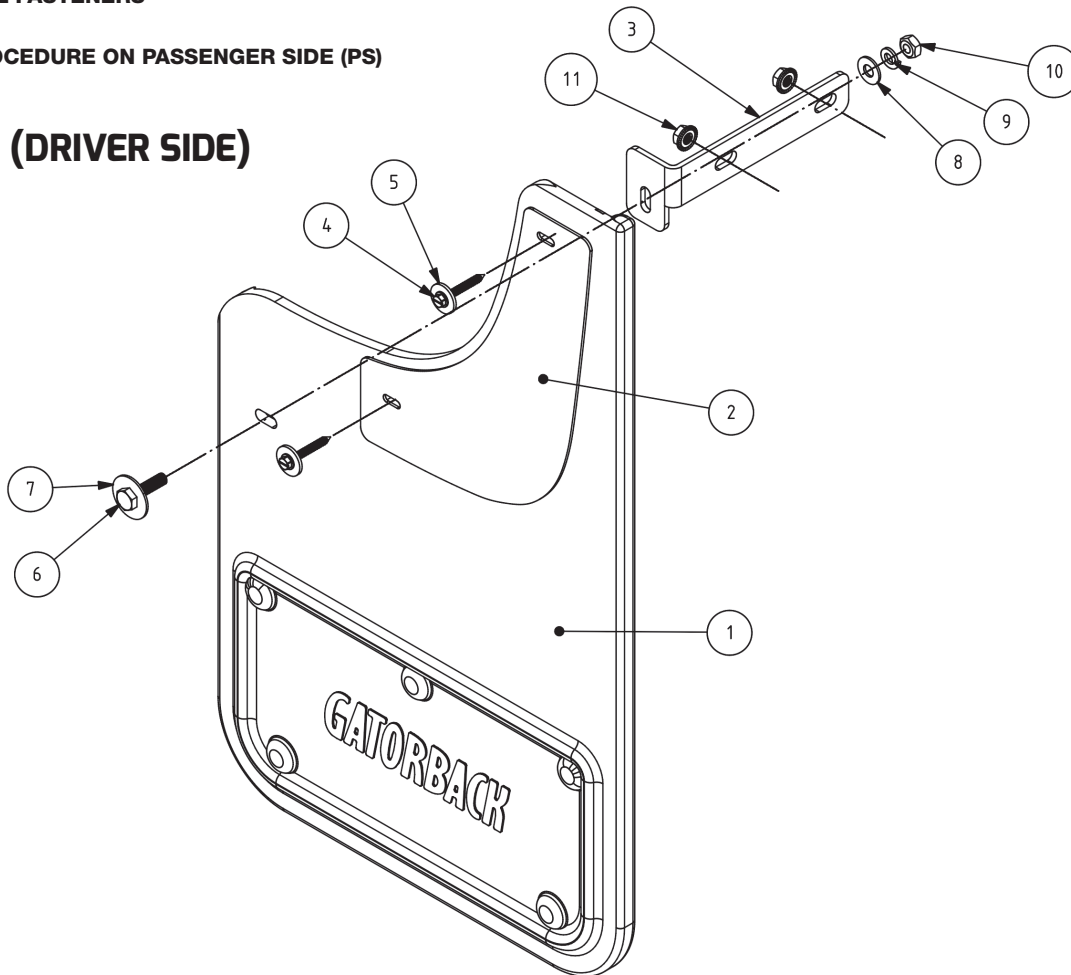

*****NOTICE*****

These instructions and enclosed parts have been provided in response to the Ford 2015 F150 SVE Bulletin. Any deviation of the installation and/or hardware may result in premature corrosion. The Manufacturer and/or Dealer Distributor are not responsible for negligent use or installation.