



# GATORBACK MUDFLAPS

## GCR42R 2017 F150 Raptor Rear Gatorback CR Mudflap Kit Installation Instructions

### IMPORTANT

The manufacturer is not responsible for negligent use of vehicle with mudflaps installed, including over-tightening of screws and bolts causing damage to vehicle or mudflaps.

### TOOLS REQUIRED:

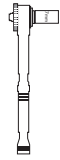

7 mm wrench or ratchet

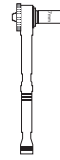

8 mm wrench or ratchet

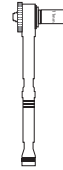

10 mm wrench & ratchet



Level or large square

### PARTS:

1. (2) Gatorback CR Mud Flap (DS & PS)

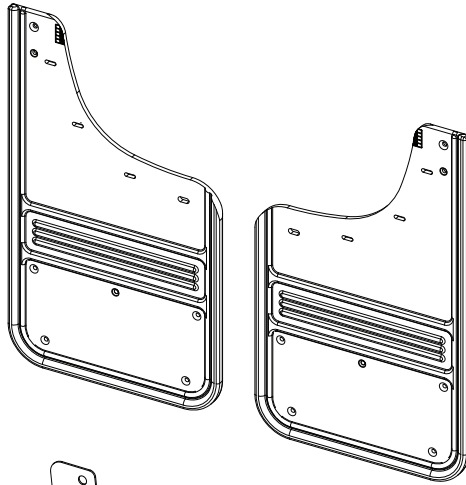

2. (2) Washer Plate (DS & PS)

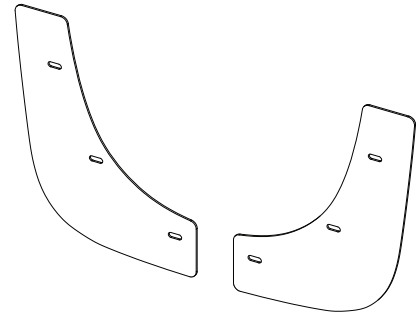

3. (2) Backing Plate (DS & PS)

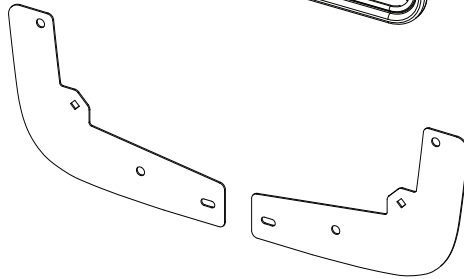

4. (2) Brace (DS & PS)

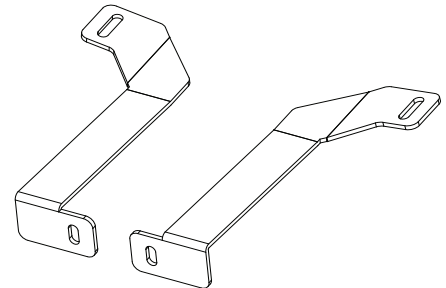

### FASTENERS:

5. (2) Nylon Snap-In Nuts for #8 screw size



6. (6) Flanged Hex Head Screw M4.2-1.41 x 28mm



7. (6) Black Nylon Washer 0.2" ID 0.45" OD

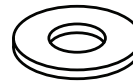

8. (4) Hex Head Cap Screw M6 x 25mm



9. (2) Oversize Washer 0.281" ID 1" OD

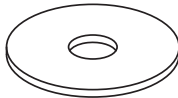

10. (6) Aluminum Washer 0.265" ID 0.688" OD

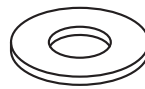

11. (4) Lock Washer M6

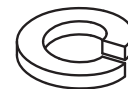

12. (4) Hex Nut M6



# INSTALLATION: Installation video available on our YouTube channel: [youtube.com/c/TruckHardwareLtd](https://youtube.com/c/TruckHardwareLtd)

**Note: Please refer to diagram during installation. Power tools not recommended.**

## 1. START ON DRIVER SIDE (DS) REAR

### 2. INSTALL BACKING PLATE

- Remove 2x factory fender flare screws on inner fender.
- Insert Nylon Snap-In Nut #5 into square hole on Backing Plate (#3).
- Install Backing Plate (#3) between fender flare and body (pull fender flare away slightly from fender to insert).
- Line up two round holes in Backing Plate #3 with two round holes in fender flare.

### 3. INSTALL GATORBACK CR MUD FLAP (DS) AND WASHER PLATE

- Loosely install Mudflap (#1) with Washer Plate (#2) using 3x #8 Flanged Hex Head Screws (#6), and 3x Nylon Washers (#7).

### 4. INSTALL BRACE (DS)

- Remove plastic push pin behind fender opening.
- Loosely attach Brace #4 to fender (see previous step) using 1x M6 Hex Head Cap Screw (#8), 2x Aluminum Washer (#10), 1x Lock Washer (#11), and 1x M6 Hex Nut (#12).
- Loosely attach Brace to Gatorback Mud Flap using 1x M6 Hex Head Cap Screw (#8), 1x Oversize Washer (#9), 1x Aluminum Washer (#10), 1x Lock Washer (#11), and 1x M6 Hex Nut (#12).

### 5. ADJUST MUD FLAP POSITION AND ALIGNMENT

- Adjust horizontal position of mud flap.
- With a level (bubble/digital) on the bottom edge of the mud flap, adjust until level.
- Carefully tighten all screws and double check that mudflap is still level.
- Adjust forward-back position of Brace so that mud flap is approximately parallel to tire tread.

### 5. TIGHTEN ALL FASTENERS

### 6. REPEAT PROCEDURE ON PASSENGER SIDE (PS)

## DIAGRAM (DRIVER SIDE)

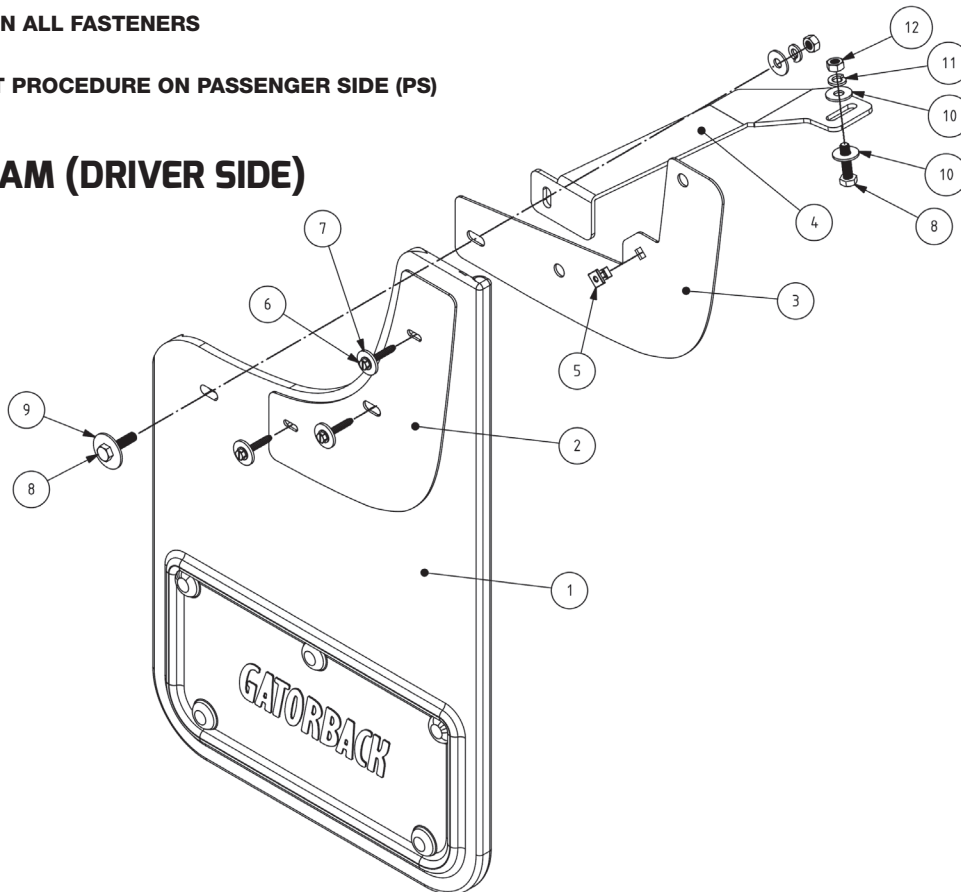

### \*\*\*NOTICE\*\*\*

*These instructions and enclosed parts have been provided in response to the Ford 2015 F150 SVE Bulletin. Any deviation of the installation and/or hardware may result in premature corrosion. The Manufacturer and/or Dealer Distributor are not responsible for negligent use or installation.*